

Accessory part

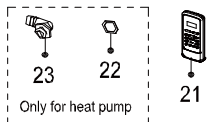

Optional part

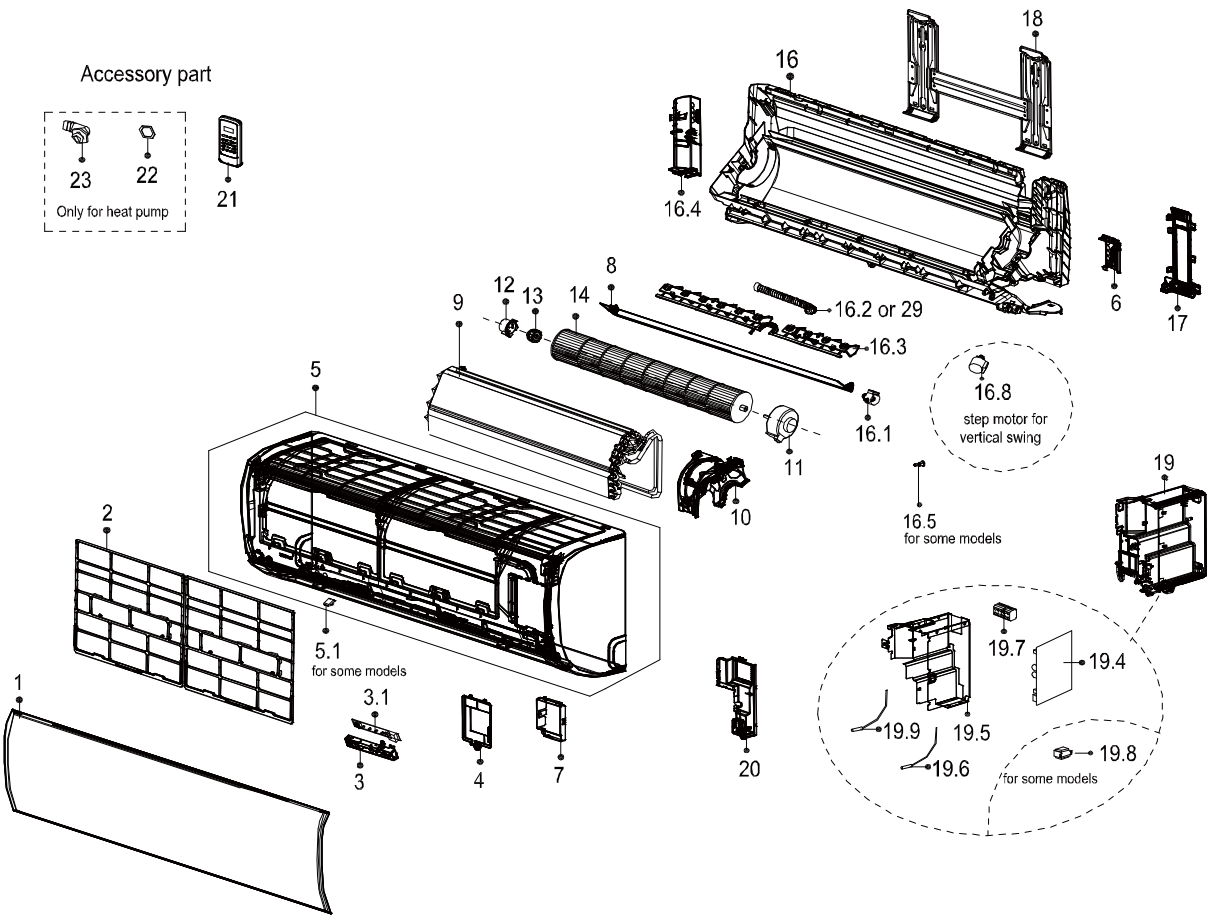
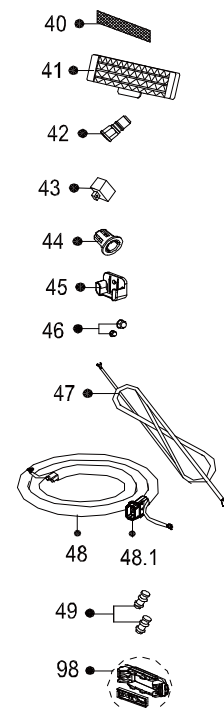

### Exploded View

产品编码(Product model) :

客户编码(Customer No) :

客户型号(Customer model) :

订单编号(Order Product Code) :

22022011013881

G0011405

KWX-12HRHI

62220-J2373101

EX_ID	Spare Parts Code	Part Name(CN)	Part Name(EN)	Qty.	Remark2	Part Status	Drawing No	MIN_ORDE R_QTY	Long Term Material(Y or N)	High Rate of Replacemen t(Y or N)	SB Type	Replace Type	Remarks
1	12122000A83978	面板部件	Panel assembly	1		In Use	KAISAI-KF35G/N1Y-AF9.1-0103	1					
2	12122000015224	过滤网	Filter	2		In Use	SA-KF35G/N1Y-AF-17	1					
3	17222000A66671	外箱分体显示盒组件	Display box subassembly	1		In Use	CE-KFR35G/N1Y-AF9.D.01.XK1.3(XK/Wifi)	1					
3.1	17122000038028	外箱分体显示板组件	Display board subassembly	1		In Use	EU-KFR28G/N1Y- M8_JD_GN.WXAS.2S2.22(XK)	1					
4	12122000013131	电器盖板	Cover Plate	1		In Use	SA-KF35G/N1Y-AF-7	1					
5	12122000013170	面板部件	Panel Frame Assembly	1		In Use	SA-KF35G/N1Y-AF-2	1					12122000A8411 4
5.1	12122000013139	螺钉盖	Screw Cap	2		In Use	SA-KF35G/N1Y-AF-2.2	1					
6	12122000013140	底座前盖板(右)	Front Cover of Chassis(Right)	1		In Use	SA-KF35G/N1Y-AF-8	1					
7	12122000013141	接口盖防护组件	Cover of Electrical Equipment Subassembly	1		In Use	SA-KF35G/N1Y-AF-7	1					
8	12122000013168	导风板部件	Louver Subassembly	1		In Use	SA-KF35G/N1Y-AF.5	1					12122000A7757 6
9	15822000008180	蒸发器部件	Evaporator assembly	1		In Use	SA-KF35G/N1Y-AFB(B8).ZL[A](J)	1					
10	12122000013129	电机盖	Motor Cover	1		In Use	SA-KF35G/N1Y-AF-6	1					
11	11002012031474	单相异步电机	Single Phase Asynchronous Motor	1		In Use	YKFG-13-4.3BL-4	1					11002012A0435 3
12	12122000000350	轴承座套	Bearing Holder	1		In Use	ZCZT-01	1					
13	12622000000131	轴承座组件	Bearing components	1		In Use	ZCZJ-01	1					12622000A0000 1
14	12100102000044	贯流风轮	Cross Flow Fan	1		In Use	GL-94'605-N	1					
16	12122000032243	室内机底座部件	Chassis assembly	1		In Use	SA-KF35G/N1Y-AF.3J	1					
16.1	11002010000143	步进电机	Stepper Motor	1		In Use	SM-24-19-16-8	1			SB012792		1100201000000 5
16.2	12100501000032	出水嘴	Drain Hose	1		In Use	KFR-26G/BP2DN1Y-IC-10	1					
16.3	12122000A26205	驱动百叶	drive Louver	10		In Use	CE-KFR35G/N1Y-AE.3-16	1					
16.4	12122000013123	底座前盖板(左)	Front Cover of Chassis(Left )	1		In Use	SA-KF35G/N1Y-AF.3-11	1					
16.5	12122000000344	防电轴(本色,POM)	Insulated Axis	1		In Use	EU-KFR35G/BP3N1Y-1A.1-1	1					
16.8	11002010A00014	步进电机	Stepper Motor	1		In Use	SM-24-19-16-89	1					
17	12122000013136	配管压板	pipe clamp board	1		In Use	SA-KF35G/N1Y-AF-3	1					
18	122220000005844	室内机安装板	Installation Plate	1		In Use	SA-KF35G/N1Y-AF.6	1					12222000A0165 3
19	17222000A63751	外机分体室内电控盒组件(中 低档)	Electronic control box subassembly (Mid-and low-end)	1		In Use	EU-KFR35G/BP2N1Y-AFB(BRDJ)- GW_JD_GN.WXNK.DK2.2(EF1/NO-IGN)	1					
19.4	17122000A40490	外机分体室内主控板组件	Main control board subassembly	1		In Use	CE-KFR35G/BP2N1Y- AF.JD.GN.WXNK.NK2.1(EF2/NEW_ERR/NO- IGN)	1					
19.6	11201007003447	管道传感器	Pipe Temperature Sensor	1		In Use	CGO-WD/GW4100-L350-XACP2-P250	0					
19.7	17400401000094	室内机室内温度传感器	Terminal	1		In Use	JXC-ADSZ-A(RS9103C-5)YF2004JX-PF-5JGD- ZRS-P-1	1					
19.9	11201007003424	室温传感器	Room Temperature Sensor	1		In Use	CGO-WD/SW4100-L350-XRBCP2BC-P300- HT1.0	0					
20	12122000013132	电控盒盖组件	Electrical Control Box Cover Subassembly	1		In Use	SA-KF35G/N1Y-AF.8	1					
21	17317000A61204	订单遥控器	Remote controller	1		In Use	RG10B(F)BGEF	1					
22	12600701000039	密封胶	seal ring	1		In Use	KC25B.4-8A	1					
23	12100509000061	出水接管	Drain Hose	1		In Use	CSJG-1	1					
40	121002040000685	冷触媒过滤网	Air Freshening Filter	1		In Use	KFR-23G/A.Y.1-10	1					
40	12100207000136	HEPA网	High Efficiency Particulate Air Filter	1		In Use	KFR-23G/I.Y.1-14A	1					1210020700013 6
45	12122000029201	遥控器安装支架组件	Bracket of remote Controller	1		In Use	RG10ZJ-1	1					
46	15500406000010	铜螺母	Copper nut	1	A01=Φ3 5mm(L)	In Use	TLM-B02	0	N	N	SB011738		1550040600001 5
46	15500406000016	铜螺母	Copper nut	1	A01=Φ3 5mm(L)	In Use	TLM-A01	0	N	N			
88	17310900A06289	WiFi模块组件	WiFi module subassembly	1		In Use	EU-OSK105.JD.TY.MWL.NET	1					