

Accessory part

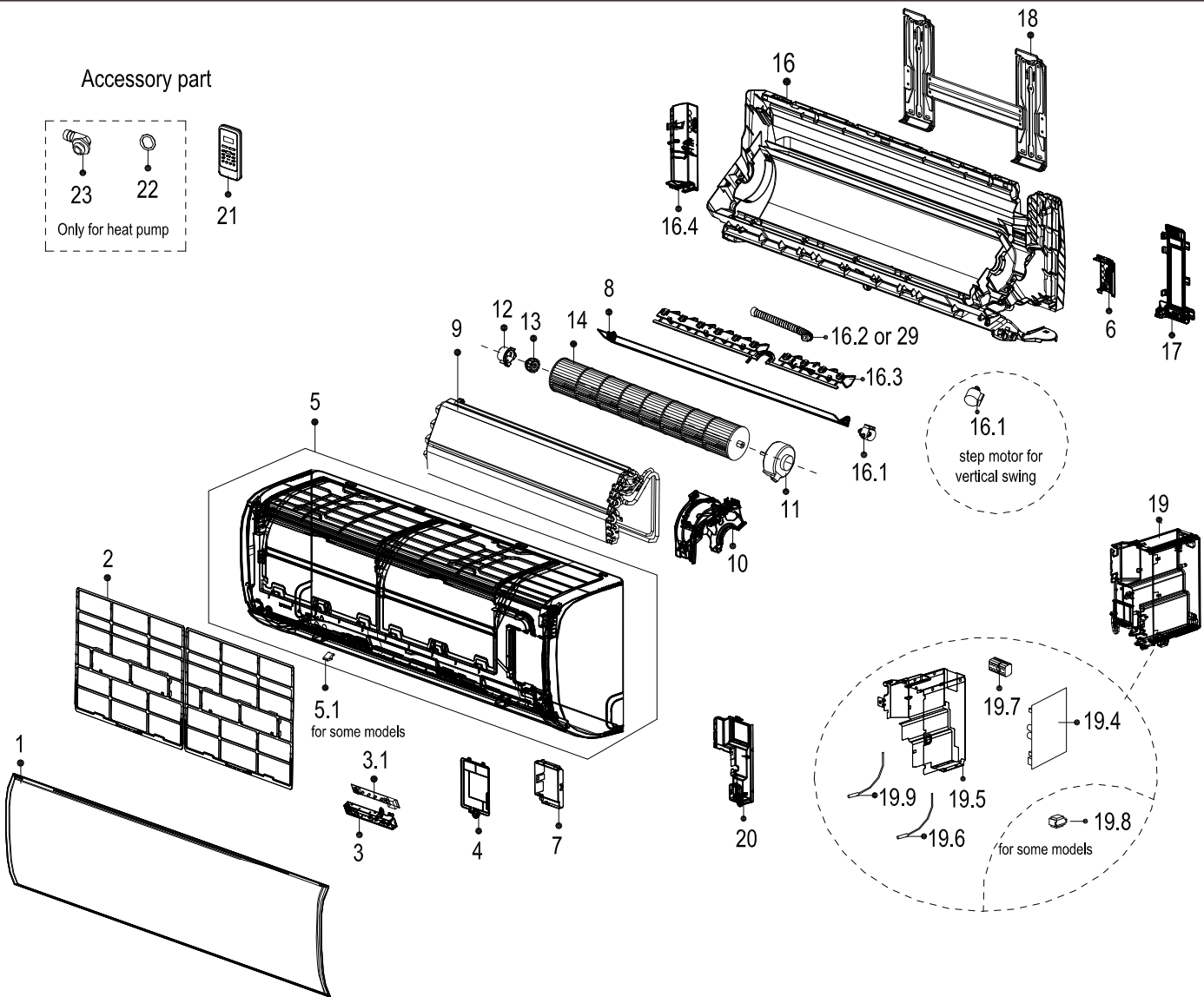

Optional part

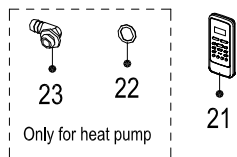
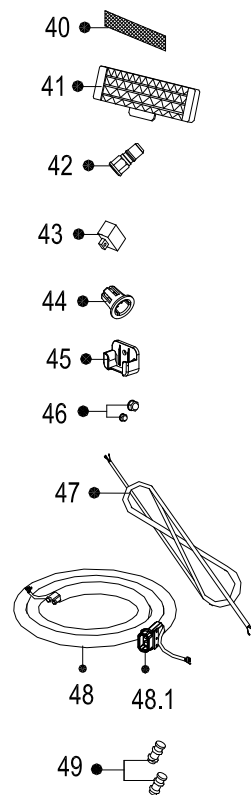

Exploded View

Product code :
Customer model :

22022011013881
KWX-12HRBI

EX_ID	Spare Parts Code	Part Name(EN)	Qty.	Min Shipments	Remark2	Part Status	Remarks	Long Term Material(Y or N)	High Rate of Replacement(Y or N)
1	12122000A78159	Panel assembly	1			In use			
2	12122000015224	Air filter	2			In use			
3	17222000A46336	Display box subassembly	1			In use			Y
3.1	17122000041914	Display board subassembly	1			In use			Y
4	12122000013131	Cover of electrical equipment	1			In use			
5	12122000013170	Panel frame assembly	1			In use			N
5.1	12122000013139	Screw Cap	2			In use			
6	12122000013140	Front cover of chassis(right)	1			In use			
7	12122000013141	Cover of electrical equipment subassembly	1			In use			
8	12122000013168	Horizontal louver assembly	1			In use			
9	15822000008180	Evaporator assembly	1			In use			
10	12122000013129	Fan motor cover	1			In use			
11	11002012031474	Single phase asynchronous motor	1			In use			Y
12	12122000000350	Bearing sleeve	1	0		In use		N	N
13	12622000000006	Beating base	1	0		In use		N	N
14	12100102000044	Cross flow fan	1			In use			
16	12122000013163	Chassis assembly	1			In use			
16.1	11002010000143	Stepper motor	1			In use			Y
16.3	12122000013167	Horizontal louver	1			In use			
16.4	12122000013123	Front cover of chassis(left)	1			In use			
17	12122000013136	pipe clamp board	1			In use			
18	12222000005844	Installation plate	1			In use			
19	17222000A56211	Electronic control box subassembly (Mid-and low-end)	1			In use			
19.4	17122000045458	Main control board subassembly	1			In use			Y

19.5	12122000013001	Electronic control box subassembly	1			In use				
19.6	11201007003447	Pipe Temperature Sensor	1	10		In use			Y	
19.7	17400401000094	Terminal	1			In use				
19.9	11201007003424	Room temperature sensor	1	10		In use			Y	
20	12122000013132	Electrical Control Box Cover Subassembly	1			In use				
21	17317000A56960	Remote controller	1			In use				
22	12600701000039	seal ring	1			In use				
23	12100509000061	Drain hose	1	0		In use		N	N	
29	12100501000032	Drain hose	1	10		In use		N	N	N
40	12100204000685	Air freshening filter	1	0		In use		N	Y	
45	12117000002115	Bracket of remote Controller	1			In use				
46	15500406000010	Copper nut	1	0	A01=6.35mm(1/4 in);B02=9.52mm(3/8in);C03=12.7mm(1/2in);D04=15.9mm(5/8in);E05=19mm(3/4in);F07=22mm(7/8in);	In use		N	N	

46	15500406000016	Copper nut	1	0	A01=6.35mm(1/4in);B02=9.52mm(3/8in);C03=12.7mm(1/2in);D04=15.9mm(5/8in);E05=19mm(3/4in);F07=22mm(7/8in);	In use			N	N
----	----------------	------------	---	---	--	--------	--	--	---	---