

Accessory part

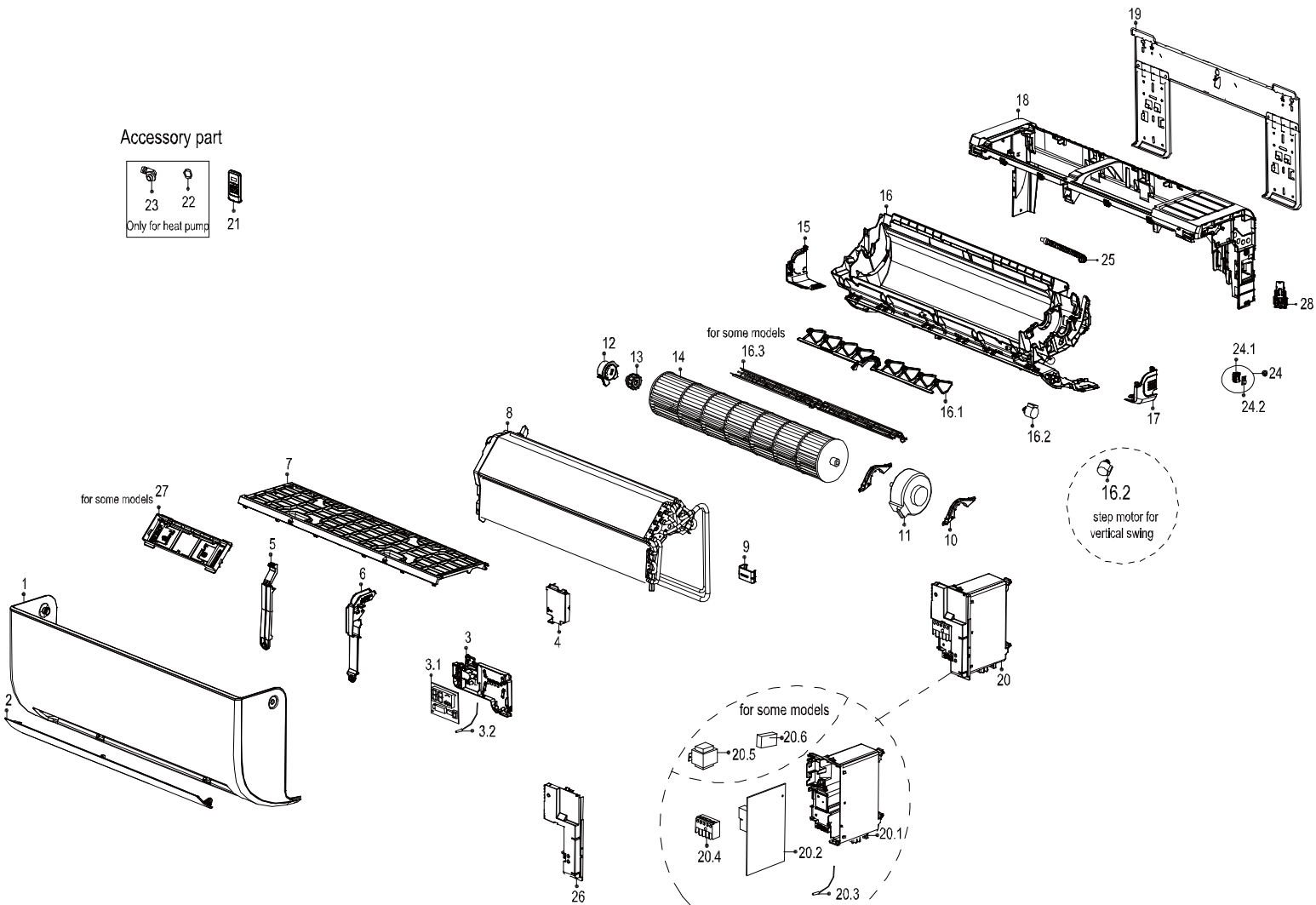
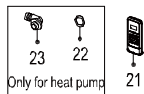

Optional part

- 40
- 41
- 42
- 43
- 44
- 45
- 46
- 47
- 48 48.1
- 49
- 50
- 98

### Exploded View

产品编码(Product model) : 22022011016384  
 客户编码(Customer No) : G0011405  
 客户型号(Customer model) : KRX-09PEGI  
 订单编码(Order Product Code) : 62220-F3864304

EX_ID	Spare Parts Code	Part Name(CN)	Part Name(EN)	Qty.	Remark2	Part Status	Drawing No	MIN_ORDER_QTY	Long Term Material(Y or N)	High Rate of Replacement(Y or N)	SB Type	Replace Type	Remarks
1	12122000A84553	面罩部件	Panel assembly	1		In Use	KAISAI-KFR35G/N1Y-AE1.1-0102	1					
2	12122000011982	导风板部件	Horizontal louver assembly	1		In Use	CE-KFR35G/N1Y-AE1.4	1					
3	17222000A21608	外销分体显示盒组件	Display box subassembly	1		In Use	EU-KFR26G/N1Y-AE.JD.GN.WXXS.XK1.4(WIFI)						
3.1	17122000021488	外销分体显示板组件	Display board subassembly	1		In Use	EU-KFR26G/N1Y-AE.JD.GN.WXXS.XS2.20						
3.2	11201007003103	室温传感器	Room Temperature Sensor	1		In Use	CGQ-WD/SW4100-L100-XHP2						
4	12122000011984	接线盖防护组件	Cover of electrical equipment subassembly	1		In Use	CE-KFR35G/N1Y-AE.9	1					
5	12122000011989	中间支撑	Intermediate support	1		In Use	CE-KFR35G/N1Y-AE-10						
6	12122000014461	中间支撑 (13U)	Intermediate support	1		In Use	CE-KFR35G/N1Y-AE-23						
7	12122000011988	过滤网组件	Filter filter subassembly	1		In Use	CE-KFR35G/N1Y-AE.5						
8	15822000008651	蒸发器部件	Evaporator Assembly	1		In Use	IL-KFR26G/N1Y-AEB(C8).ZLA(J)	1					
9	12122000011987	配管压板	pipe clamp board	1		In Use	CE-KFR35G/N1Y-AE-12	1					
10	12122000011994	电机压板	Fixing board of fan motor	2		In Use	CE-KFR35G/N1Y-AE-7	1					
11	11002015000051	无刷直流电机	Brushless DC Motor	1		In Use	ZKFP-20-8-6-7	4	N	Y			
12	12122000011978	轴承座套	Bearing holder	1		In Use	CE-KFR35G/N1Y-AE-6	1					
13	12622000000131	轴承座组件	Bearing components	1		In Use	ZCZZJ-01	1					
14	12100102000044	贯流风轮	Cross flow fan	1		In Use	GL-94*605-N	1					
15	12122000011983	底盘前盖板(左)	Front cover of chassis(left)	1		In Use	CE-KFR35G/N1Y-AE-2	1					
16	12122000A67810	室内机底盘部件(下)	Chassis assembly(below)	1		In Use	CE-KFR35G/N1Y-AE.3C	1					
16.1	12122000A26205	驱动百叶	drive Louver	10		In Use	CE-KFR35G/N1Y-AE.3-16	1					
16.2	11002010A00014	步进电机	Stepper motor	1		In Use	SM-24-19-16-89						
16.2	11002010000143	步进电机	Stepper motor	1		In Use	SM-24-19-16-8						
17	12122000011986	底盘前盖板(右)	Front cover of chassis(right)	1		In Use	CE-KFR35G/N1Y-AE-3	1					
18	12122000015949	室内机底盘部件(上)	Chassis assembly(above)	1		In Use	CE-KFR35G/N1Y-AE.2	1					
19	12222000005042	室内机安装板	Installation plate	1		In Use	CE-KFR35G/N1Y-AE.6	1					
20	17222000A60993	外销分体室内电控盒组件(中低端) RoHS EU-KFR26G/BP3N1Y-AEBAU(RD0)-GW.JD.GN.WXNK.DK2.6 (EE1/ION) 室外供电 1W待机 (定制选配)	Electronic control box subassembly (Mid-and low-end)	1		In Use	EU-KFR26G/BP3N1Y-AEBAU(RD0)-GW.JD.GN.WXNK.DK2.6 (EE1/ION)	1					
20.1	12122000011980	电控盒结构组件	Electronic control box subassembly	1		In Use	CE-KFR35G/N1Y-AE.7	1					
20.2	17122000050896	外销分体室内主控板组件	Main control board subassembly	1		In Use	EU-KFR26G/BP3N1Y-AE.JD.GN.WXNK.NK2.7 (EE1)						
20.3	11201007003447	管温传感器	Pipe Temperature Sensor	1		In Use	CGQ-WD/GW4100-L350-XACP2-P250						
20.4	17400401000576	接线座	Wire joint	1		In Use	JXZ-AD5ZG2-A	1					
21	17317000A63534	订单遥控器	Remote controller	1		In Use	RG10B1(F)/BGEF	1					
22	12600701000039	密封圈	seal ring	1		In Use	KC25B.4-8A	1					
23	12100509000061	出水接管	Drain hose	1		In Use	CSJG-1	1					
24	17222000009674	外销分体室内电控盒组件(中低端)	Electronic control box subassembly (Mid-and low-end)	1		In Use	SA-KF32G/Y-KEY.JD.GN.WXNK.DK2.1	1					
24.1	12122000011990	应急开关盒	Emergency switch box	1		In Use	CE-KFR35G/N1Y-AE-4						
24.2	17122000018905	按键板组件	Key board subassembly	1		In Use	CE-KF26G/AE-KEY.JD.GN.WXNK.NK2.1	1					
25	12100501000032	出水喉	Drain hose	1		In Use	KFR-26G/BP2DN1Y-IC-10	1					
26	12122000011985	电控盒盖组件	Electrical Control Box Cover Subassembly	1		In Use	CE-KFR35G/N1Y-AE.8	1					
27	12122000014462	空气清新网支架	Filter support	2		In Use	CE-KFR35G/N1Y-AE-21						

28	1212200015241	底盘支撑部件	Support plate	2		In Use	CE-KFR35G/N1Y-AE.15						
40	12100204000685	冷触媒过滤网	Air freshening filter	1		In Use	KFR-23G/AY.1-10	1					
40	12100207000136	HEPA网	High efficiency particulate air filter	1		In Use	KFR-23G/IY.1-14A	1					
42	15500209000001	检测阀	Check valve	1		In Use	JCF-01	1					
43	17400609A00027	正负离子发生器	Ion generator	1		In Use	ZFLZ-10	1					
45	12122000029201	遥控器安装支架组件	Bracket of remote Controller	1		In Use	RG10ZJ-1	1					
46	15500406000010	铜螺母	Copper nut	1	A01=6.35mm(1/4in);B02=9.52mm(3/8in);C03=12.7mm(1/2in);D04=15.9mm(5/8in);E05=19mm(3/4in);F07=22mm(7/8in);	In Use	TLM-B02	0	N	N			
46	15500406000016	铜螺母	Copper nut	1	A01=6.35mm(1/4in);B02=9.52mm(3/8in);C03=12.7mm(1/2in);D04=15.9mm(5/8in);E05=19mm(3/4in);F07=22mm(7/8in);	In Use	TLM-A01	0	N	N			
98	17310900A06289	WiFi模块组件	WiFi module subassembly	1		In Use	EU-OSK105.JD.TY.MWL.NET	1					