

Accessory part

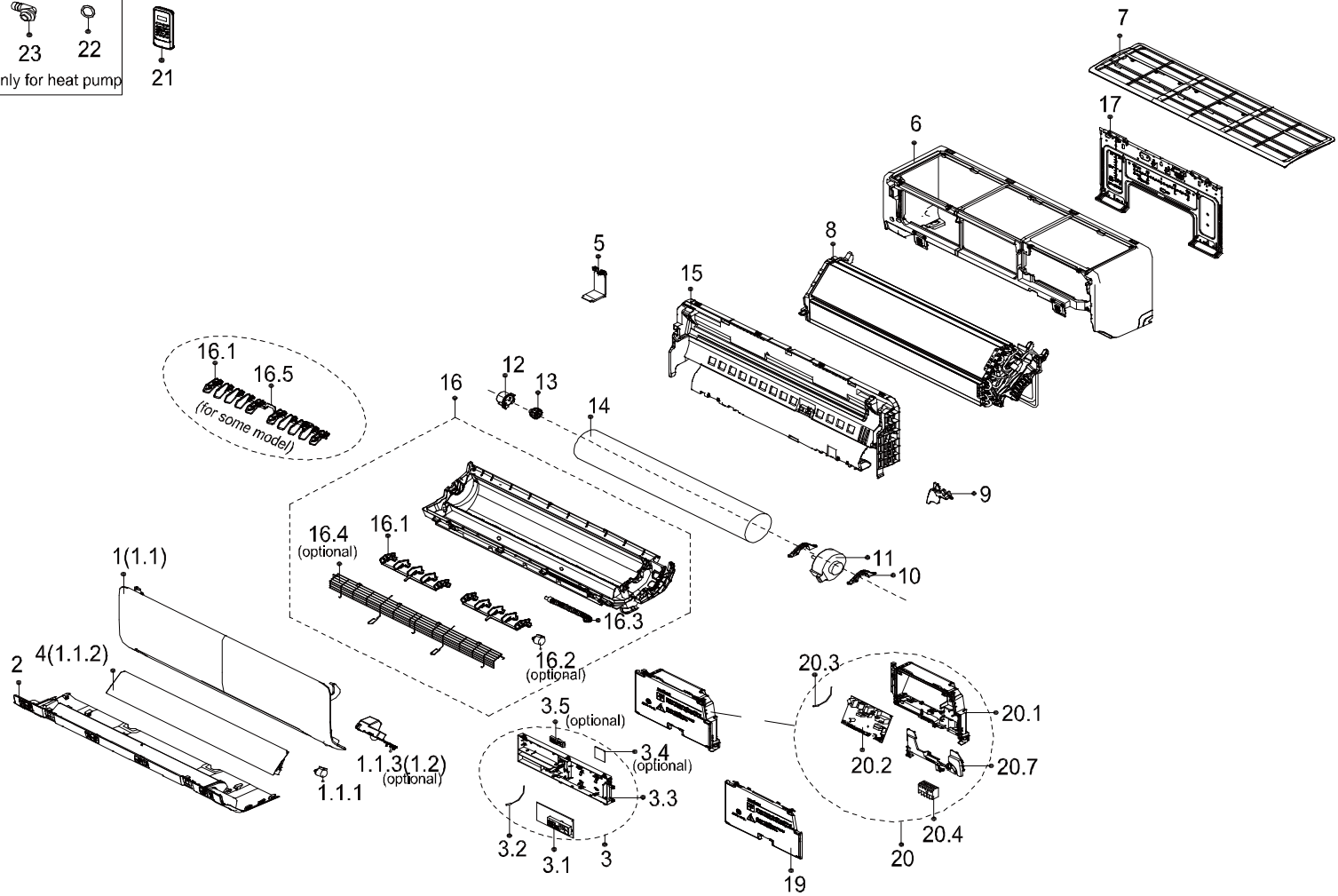
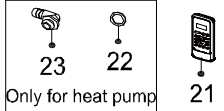

- Optional part
- 40
 - 41
 - 42
 - 16.6(43)
 - 44
 - 45
 - 46
 - 47
 - 48
 - 48.1
 - 49
 - 50

Exploded View

产品编码(Product model) : 22022011015647
 客户编码(Customer No) : G0011405
 客户型号(Customer model) : KRP-09MEGI
 订单编码(Order Product Code) : 62220-G3039701

EX_ID	Spare Parts Code	Part Name(CN)	Part Name(EN)	Qty.	Remark2	Part Status	Drawing No	MIN_ORDER_QTY	Long Term Material(Y or N)	High Rate of Replacement(Y or N)	SB Type	Replace Type	Remarks
1	12122000026983	面板部件	Panel assembly	1		In Use	CE-KFR35G/BP2DN8Y-EP.5A	1					
2	12122000A83302	面板部件	Panel assembly	1		In Use	CE-KFR35G/BP2DN8Y-EP21.4	1					
3	17222000A59009	外销分体显示盒组件	Display box subassembly	1		In Use	EU-KFR26G/BP3N8Y-EPBU(RD6)-GW_JD.GN.WXXS.XK1.3(AG-DISP,T1,WIFI)						
3.1	17122000050213	外销分体显示板组件	Display board subassembly	1		In Use	EU-KFR26G/BP3N8Y-EPBU(RD6)-GW_JD.GN.WXXS.XS2.1(AG-DISP,T1)						
3.2	11201007003103	室温传感器	Room Temperature Sensor	1		In Use	CGQ-WD/SW4100-L100-XHP2	0					
3.3	12122000026921	显示灯盒	Display box	1		In Use	EU-KFR26G/BP3N8Y-EPBU(RD6)-GW_JD.GN.WXXS.XK1.1.1	1					
4	12122000A88584	面板部件	Panel assembly	1		In Use	KAISAI-KFR35G/BP2DN8Y-EP11.5B-0101	1					
5	12122000026621	底盘支撑I	Chassis support I	1		In Use	CE-KFR35G/BP2DN8Y-EP.1-2	1					
6	12122000A85083	面框部件	Panel frame assembly	1		In Use	CE-KFR35G/BP2DN8Y-EP11.3	1					
7	12122000026428	过滤网组件	Filter filter subassembly	1		In Use	CE-KFR35G/BP2DN8Y-EP.6	1					
8	15822000010598	蒸发器部件	Evaporator assembly	1		In Use	EU-KFR35G/BP3N8Y-EPBU(RD6))-GW.ZL	1					
9	12122000026609	配管压板	pipe clamp board	1		In Use	CE-KFR35G/BP2DN8Y-EP-1	1					
10	12122000011994	电机压板	Fixing board of fan motor	2		In Use	CE-KFR35G/N1Y-AE-7	1					
11	11002015000051	无刷直流电机	Brushless DC Motor	1		In Use	ZKFP-20-8-6-7	4	N	Y			
12	12122000000350	轴承座套	Bearing holder	1		In Use	ZCZT-01	1					
13	12622000000131	轴承组件	Bearing components	1		In Use	ZCZZJ-01	1					
14	12100102000696	贯流风轮	Cross flow fan	1		In Use	GL-98*638-IN	1					
15	12122000026603	室内机底盘部件(上)	Chassis assembly(above)	1		In Use	CE-KFR35G/BP2DN8Y-EP.1	1					
16	12122000026615	室内机底盘部件(下)	Chassis assembly(below)	1		In Use	CE-KFR35G/BP2DN8Y-EP.2	1					
16.1	12122000026617	百叶	Horizontal louver	4		In Use	CE-KFR35G/BP2DN8Y-EP.2-15B	1					
16.1	12122000026616	百叶	Horizontal louver	6		In Use	CE-KFR35G/BP2DN8Y-EP.2-15A	1					
16.2	11002010001486	步进电机	Stepper motor	1		In Use	SM-24-19-16-140	1					
16.3	12100501000032	出水喉	Drain hose	1		In Use	KFR-26G/BP2DN1Y-IC-10	1					
16.5	12122000026618	百叶连杆	Connecting rod of louver	1		In Use	CE-KFR35G/BP2DN8Y-EP.2-16	1					
16.6	17400609000620	正负离子发生器	Ionizer+ generator	1		In Use	ZFLZ-15	1					
17	12222000013705	室内机安装板组件	Installation plate subassembly	1		In Use	CE-KFR35G/BP2DN8Y-EP.40	1					
19	12122000026601	电控盒盖组件	Cover of electronic control box subassembly	1		In Use	CE-KFR35G/BP2DN8Y-EP.9	1					
20	17222000032079	外销分体室内电控盒组件(中低端)	Electronic control box subassembly (Mid-and low-end)	1		In Use	EU-KFR26G/BP3N8Y-EPBU(RD6)-GW_JD.GN.WXNK_DK2.2	1					
20.1	12122000026606	电控盒结构组件	Electronic control box subassembly	1		In Use	CE-KFR35G/BP2DN8Y-EP.8	1					
20.2	17122000049354	外销分体室内主控板组件	Main control board subassembly	1		In Use	EU-KFR26G/BP3N8Y-EPBU(RD6)-GW_JD.GN.WXNK_NK2.3						
20.3	11201007003445	管温传感器	Pipe Temperature Sensor	1		In Use	CGQ-WD/GW4100-L500-XACP2-P400	0					
20.4	17400401000576	接线座	Wire joint	1		In Use	JXZ-AD5ZG2-A	1					
20.7	12122000026605	电控盒支架	Electrical Control Box holder	1		In Use	CE-KFR35G/BP2DN8Y-EP.8-4	1					
21	17317000A58345	订单遥控器	Remote controller	1		In Use	RG10A1(F2S)/BGEF	1					
22	12600701000039	密封圈	seal ring	1		In Use	KC25B.4-8A	1					
23	12100509000061	出水接管	Drain hose	1		In Use	CSJG-1	1					
40	12100204000685	冷触媒过滤网	Air freshening filter	1		In Use	KFR-23G/AY.1-10	1					
40	12100207000136	HEPA网	High efficiency particulate air filter	1		In Use	KFR-23G/Y.1-14A	1					
42	15500209000001	检测阀	Check valve	1		In Use	JCF-01	1					
45	12122000029201	遥控器安装支架组件	Bracket of remote Controller	1		In Use	RG10ZJ-1	1					

46	15500406000010	铜螺母	Copper nut	1	A01=6.35mm(1/4in);B02=9.52mm(3/8in);C03=12.7mm(1/2in);D04=15.9mm(5/8in);E05=19mm(3/4in);F07=22mm(7/8in);	In Use	TLM-B02	0	N	N			
46	15500406000016	铜螺母	Copper nut	1	A01=6.35mm(1/4in);B02=9.52mm(3/8in);C03=12.7mm(1/2in);D04=15.9mm(5/8in);E05=19mm(3/4in);F07=22mm(7/8in);	In Use	TLM-A01	0	N	N			