

## **Air to water heat pump**

### **Split System (single phase type)**

**Hydraulic unit**  
WS \*G140DC6

**Outdoor unit**  
WO \*G112LCT  
WO \*G140LCT

### **Split System (3-phase type)**

**Hydraulic unit**  
WS \*K160DC9

**Outdoor unit**  
WO \*K112LCT  
WO \*K140LCT  
WO \*K160LCT



## **Maintenance Document**

**Intended for professional use**

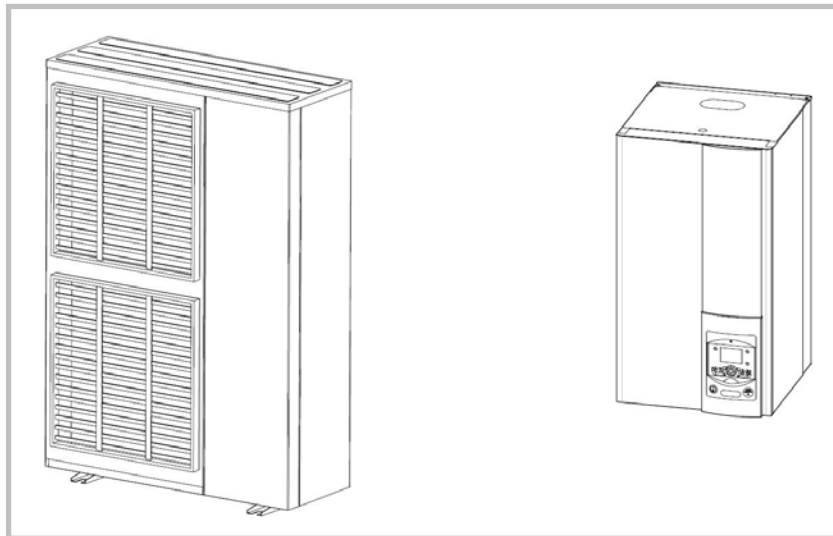

**Fujitsu General (Euro) GmbH**  
Wertstrasse 20  
40549 Düsseldorf - Germany

Subject to change without notice  
Non contractual document



---

# Contents

---

<b>1</b>	<b>Control and test .....</b>	<b>5</b>
1.1	Control of Electric Backups .....	5
1.2	Sensor and Input Test Mode.....	5
<b>2</b>	<b>Faults .....</b>	<b>6</b>
2.1	Fault List.....	6
2.1.1	Hydraulic Unit Fault.....	6
2.1.2	Outdoor Unit Fault.....	8
2.2	Outdoor Unit Clearing.....	9
2.2.1	Failures with Error Code .....	9
2.2.2	Failures With No Error Code.....	31
2.3	Sensor Values .....	35
2.3.1	Outdoor Unit Temperature Sensors	35
2.3.2	Hydraulic Unit Temperature Sensors	35
2.4	Service parts information.....	36
2.4.1	Service parts information 1 : Compressor .....	36
2.4.2	Service parts information 2 : Inverter compressor .....	37
2.4.3	Service parts information 3 : Outdoor unit electronic expansion valve (EEV, EEV(INJ)) 38	
2.4.4	Service parts information 4 : Outdoor unit solenoid valve (SV).....	39
2.5	Operating Limits.....	40
<b>3</b>	<b>Failures .....</b>	<b>41</b>
3.1	Hydraulic, Electric and Refrigeration Systems .....	41
3.1.1	Hydraulic System .....	41
3.1.2	Electrical System .....	42
3.1.3	Refrigeration System .....	43
3.2	Compressor Operating Checks....	45
3.3	Refrigeration Circuit Leak Test ....	45
3.4	Troubleshooting .....	45
<b>4</b>	<b>Control Settings.....</b>	<b>46</b>
4.1	General.....	46
4.2	Function Table.....	47
4.3	Adjustment Function Details.....	53
4.3.1	Date and Time Functions.....	53
4.3.2	User Interface Functions.....	53
4.3.3	Time Program Functions (heating circuit 1 & 2, DHW, cooling) .....	54
4.3.4	Heating Circuit 1 & 2 Functions .....	55
4.3.5	Cooling Circuit 1 Functions .....	62
4.3.6	DHW Functions.....	68
4.3.7	Swimming Pool Functions.....	71
4.3.8	Heat Pump Functions .....	71
4.3.9	Supplementary source.....	73
4.3.10	DHW Tank Functions .....	74
4.3.11	Configuration Functions.....	76
4.3.12	Error Functions.....	78
4.3.13	Maintenance / Special Operating Mode Functions .....	80
4.3.14	Input / Output Testing Functions ...	82
4.3.15	Status Functions.....	83
4.3.16	Generator Diagnosis Functions.....	88
4.3.17	Consumer Diagnosis Functions ....	89
<b>5</b>	<b>Annual Maintenance Services .....</b>	<b>92</b>
5.1	Hydraulic Circuit .....	92
5.2	Outdoor unit.....	92
5.3	Electrical .....	92
5.4	Operating checks .....	92

---

<b>6</b>	<b>Disassembly Process of Outdoor Unit.....</b>	<b>93</b>
6.1	Single phase type .....	93
6.1.1	Appearance.....	93
6.1.2	Service panel removal.....	93
6.1.3	Top panel removal .....	93
6.1.4	MAIN PCB, FILTER PCB, and INDICATOR PCB removal .....	94
6.1.5	FAN MOTOR removal.....	96
6.1.6	VALVE COVER removal.....	96
6.1.7	RIGHT PANEL removal .....	97
6.1.8	THERMISTOR removal.....	97
6.1.9	SOLENOID COIL removal .....	98
6.1.10	EEV COIL removal.....	99
6.1.11	PRESSURE SENSOR removal ....	99
6.1.12	COMPRESSOR removal .....	99
6.2	3-phase type .....	99
6.2.1	Appearance.....	99
6.2.2	Service panel removal.....	99
6.2.3	Insulation sheet removal.....	99
6.2.4	Main PCB removal.....	99
6.2.5	INVERTER, PFC, FILTER, and CAPACITOR PCB removal .....	99
6.2.6	FAN MOTOR removal .....	99
6.2.7	TOP PANEL removal.....	99
6.2.8	PIPE COVER FRONT removal .....	99
6.2.9	RIGHT PANEL removal.....	99
6.2.10	REACTOR removal .....	99
6.2.11	THERMISTOR removal .....	99
6.2.12	SOLENOID COIL removal.....	99
6.2.13	EEV COIL removal .....	99
6.2.14	PRESSURE SENSOR removal.....	99
6.2.15	COMPRESSOR removal.....	99
6.3	Precautions for exchange of refrigerant-cycle-parts .....	99

---

# 1 Control and test

## 1.1 Control of Electric Backups

	H 33	EX 1			EX 2		EX 3	
	Outdoor Unit Fault (370)	Load-shedding (EJP)			Off-peak/peak hours		External fault (369)	
		0 V	230 V	230 V	0 V	230 V	0 V	230 V
EJP lock signal (I 2920)			"released"	"locked"				
HEAT PUMP	OFF	ON	ON	OFF	ON	ON	ON	OFF
DHW auxiliary	ON (1)	ON	OFF	OFF	ON	OFF	ON	OFF
1st stage elec. auxiliary	ON (2)	ON	OFF	OFF	ON	ON	ON	OFF
2nd stage elec. auxiliary	ON (2)	ON	OFF	OFF	ON	ON	ON	OFF
Boiler backup	ON (2)	ON	ON	ON	ON	ON	ON	OFF

(1) subject to authorization by EX2

(2) provided the outdoor temperature is less than the setting on "2884 or 3700" (+2° from the beginning)

## 1.2 Sensor and Input Test Mode

LINE	SENSOR	INPUT	OUTPUT	WATERSTAGE
7700			QX	Relay test
7710			UX1	Output test
7712			UX1	PWM-Signal
7722			DO2	Cooling mode
7723			D3	Heat pump
7724			UX3	Output test ("Inverter" command)
7725			UX3	Voltage signal (Ux3)
7820	BX1			Sensor temp (HP flow temperature)
7821	BX2			Sensor temp (HP return temperature)
7822	BX3			Sensor temp (DHW temperature)
7823	BX4			Sensor temp (Outside temperature)
7911		EX1		Input (Power shedding, EJP)
7912		EX2		Input (Tariffs day/night)
7913		EX3		Input (External fault)
7973	BX31			Sensor temp (Mixing circuit temp.)
7976	BX34			Sensor temp (Swimming pool exchanger temperature)
7996	H33			Contact state

## 2 Faults

### 2.1 Fault List

#### 2.1.1 Hydraulic Unit Fault

Faults which occur on the Hydraulic Unit are shown by the symbol . Press the info key for details on the cause of the fault. The following information is displayed:

- Description of the error
- Location of the error (sensor or contact)
- Reset. Depending on its type, the fault can be manually or automatically deleted:
- Manual delete: the text displayed when pressing the info key shows "reset?". Press OK once, the yes flashes; press again to confirm deletion of the fault.
- Faults whose deletion is automatic are automatically reset.
- Heat pump op: shows whether or not the heat pump operates despite the fault.

No.: Designation of error	Location (connection)	Reset		HP op
		Manual	Auto	
10: Outdoor sensor	X86	No	No	Yes
33: Flow sensor HP	X70	No	No	Yes
44: Return sensor HP	X70	No	No	Yes
50: DHW sensor 1	X84	No	No	Yes
60: Room sensor 1		No	No	Yes
65: Room sensor 2		No	No	Yes
105: Maintenance message		No	No	Yes
121: Flow temp HC1 (too low)		No	No	Yes
122: Flow temp HC2 (too low)		No	No	Yes
127: Legionella temp		No	No	Yes
369: External fault (safety component)				No
370: Thermodynamic source*		No	No	No
No connection	the polarity of the room sensor is not respected.	-	-	No

\* A fault in the outdoor unit is indicated by LED located on the Hydraulic Unit interface board.

LED display		Fault description
LED 2 (green)	LED 1 (red)	
1 Flash	1 Flash	Communication error between Hydraulic Unit and Outdoor unit.
4 Flashes	1 Flash	Heat pump capacity signal error (Open or short).
4 Flashes	2 Flashes	Hydraulic Unit heat-exchange thermistor Error.
6 Flashes	3 Flashes	Inverter error.
6 Flashes	4 Flashes	Active filter error.
7 Flashes	1 Flash	Discharge thermistor error.
7 Flashes	2 Flashes	Compressor thermistor error.
7 Flashes	3 Flashes	Heat-exchange thermistor (outlet) error. Heat-exchange thermistor (intermediate) error.
7 Flashes	4 Flashes	Outdoor thermistor error.
7 Flashes	7 Flashes	Heat sink thermistor error.
7 Flashes	8 Flashes	Expansion valve thermistor error.
8 Flashes	4 Flashes	Current sensor error.
8 Flashes	6 Flashes	Pressure sensor error.
9 Flashes	4 Flashes	Current trip.
9 Flashes	5 Flashes	Detection of compressor position error. Compressor start up error.
9 Flashes	7 Flashes	Outdoor unit fan motor error.
10 Flashes	1 Flash	Discharge temperature protection.
10 Flashes	3 Flashes	Compressor temperature protection.
10 Flashes	5 Flashes	Low pressure abnormal.
Continuous flashing (1 sec ON / 1 sec OFF)		Pump down operation.

**Faults external to the heat pump**

Any safety device (e.g. thermostat pressure switch) wired to input Ex3 (E20) allows external problems to be reported and the heat pump to be immediately

stopped. For example, a safety thermostat on the heating floor can be wired to input Ex3 (E20) to avoid excessively high temperatures in the floor.

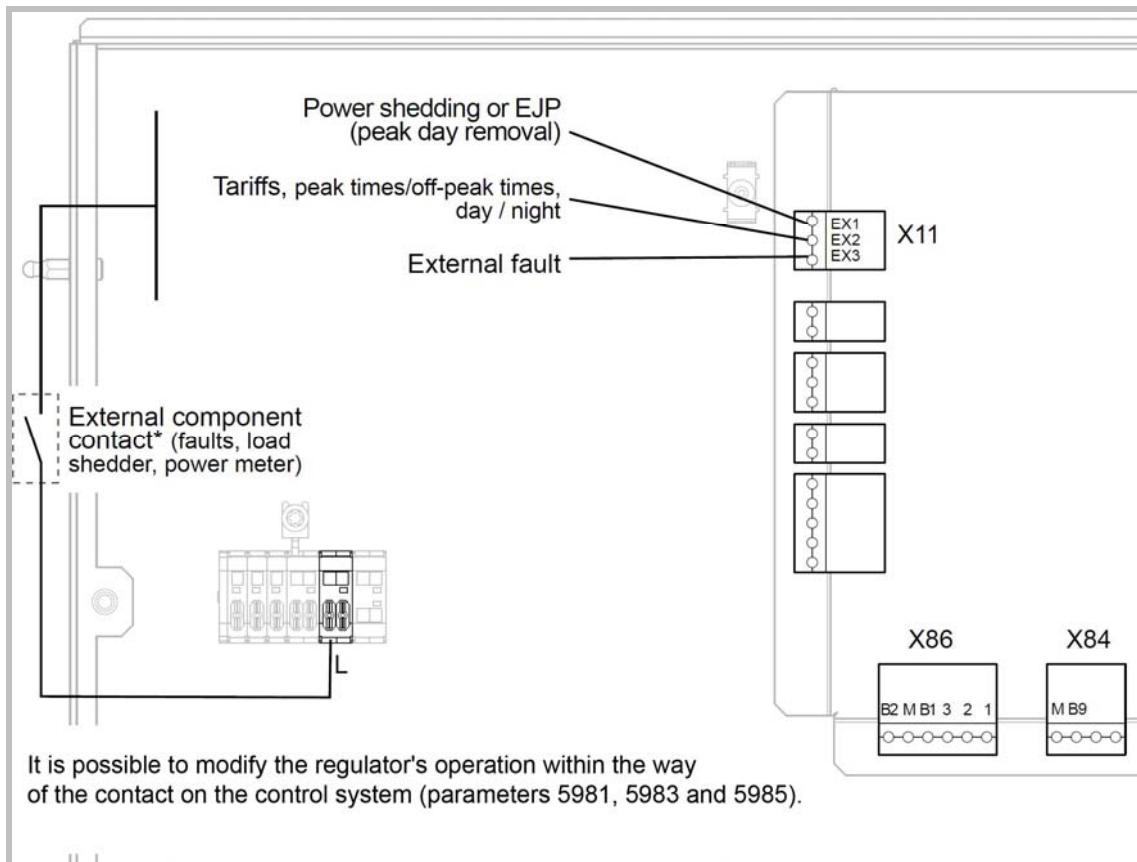

Figure 1: Typical Wiring of External Devices

### 2.1.2 Outdoor Unit Fault

When the system is switched back on after a power outage, the Hydraulic Unit may display fault 370 for a few tens of seconds. This is not a serious problem. It simply means that the outdoor unit is running its tests. Once the tests have been completed, the fault should disappear.

If it doesn't, if a fault has occurred on the outdoor unit as indicated by the Hydraulic Unit, you must remove the front (right-hand) facing from the outdoor unit. Faults are coded by LED flashes. Error messages are listed in the table below:

**On the outdoor unit**

When an error occurs:

- The diode "ERROR" (2) blinks  
Press once on the switch "ENTER" (SW4)
- The "ERROR" (2) diode blinks several times depending on the error's type

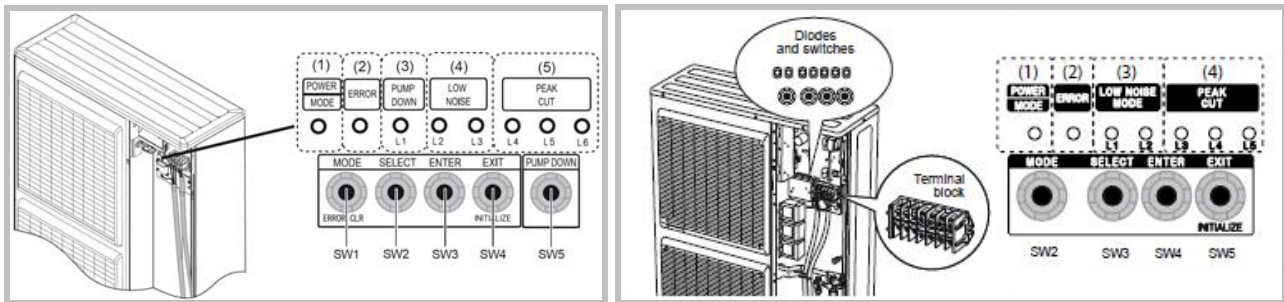

LED display on the outdoor unit (single phase and 3-phase)

LED display		Outdoor unit	Diagnosis	Clear
Hydraulic Unit Green	Red			
1 flash	1 flash	Off	Serial reverse transfer error.	1
		1 flash	Serial forward transfer error.	2
4 flashes	1 flash	22 flashes	Heat pump capacity signal error	4
4 flashes	2 flashes	22 flashes	Hydraulic Unit Heat ex. Sensor error	5
6 flashes	3 flashes	18 flashes	Inverter error.	20
6 flashes	4 flashes	19 flashes	Active filter error (single phase)	21
7 flashes	1 flash	2 flashes	P.F.C. error (3-phase)	27
7 flashes	2 flashes	8 flashes	Discharge thermistor error.	7
7 flashes	3 flashes	5 flashes	Compressor thermistor error.	11
7 flashes	4 flashes	4 flashes	Heat-exchange thermistor (intermediate) error.	12
7 flashes	7 flashes	7 flashes	Heat-exchange thermistor (outlet) error.	8
7 flashes	8 flashes	7 flashes	Outdoor temperature thermistor error.	9
7 flashes	7 flashes	9 flashes	Heat sink thermistor error.	10
7 flashes	8 flashes	6 flashes	Expansion valve thermistor error.	14
8 flashes	6 flashes	3 flashes	Pressure sensor error.	24
9 flashes	4 flashes	13 flashes	Current trip (permanent stoppage).	15
9 flashes	5 flashes	14 flashes	Detection of compressor position error (permanent stoppage).	33
		15 flashes	Compressor start up error (permanent stoppage).	17
9 flashes	7 flashes	16 flashes	Outdoor unit fan 1 motor error.	18
		17 flashes	Outdoor unit fan 2 motor error.	
10 flashes	1 flash	11 flashes	Discharge temperature protection (permanent stoppage).	22
10 flashes	3 flashes	12 flashes	Compressor temperature protection (permanent stoppage).	25
10 flashes	5 flashes	20 flashes	Low pressure abnormal.	26
Continuous flashing			Pump down operation.	
Continuous lighting	Off		Defrosting.	



## 2.2 Outdoor Unit Clearing

This section describes the techniques which can be used to identify the failure.

### 2.2.1 Failures with Error Code

#### **Clear 1: Serial reverse transfer error**

Hydraulic Unit LED: Green 1 flash / Red 1 flash

Outdoor Unit LED: Off

Probable causes:

- Misconnection.
- External cause.
- Main PCB failure.

Check:

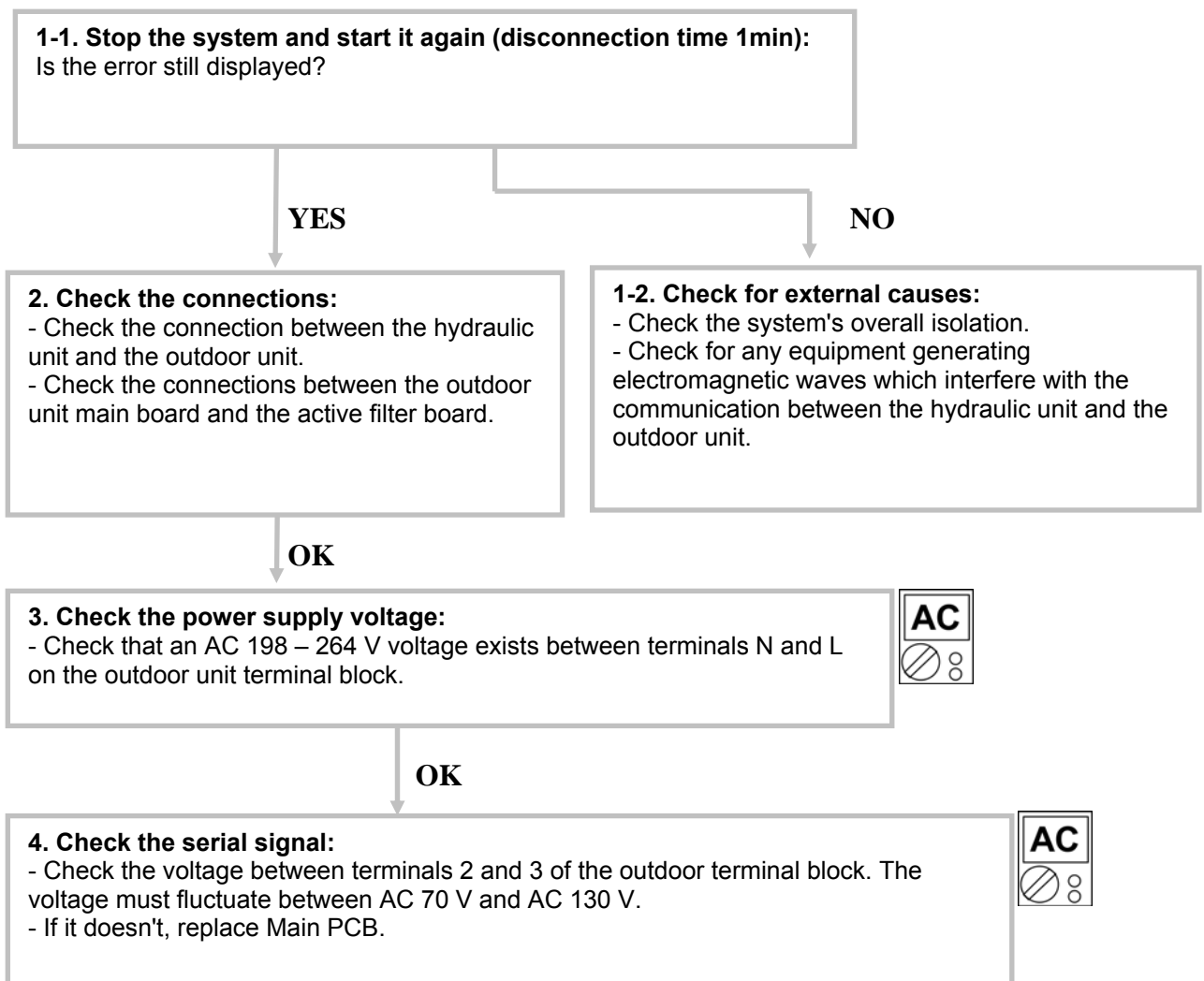

**Clear 2: Serial forward transfer error**

Hydraulic Unit LED: Green 1 flash / Red 1 flash

Outdoor Unit LED: 1 flash

Probable causes:

- Misconnection.
- External cause.
- Interface PCB failure.

Check:

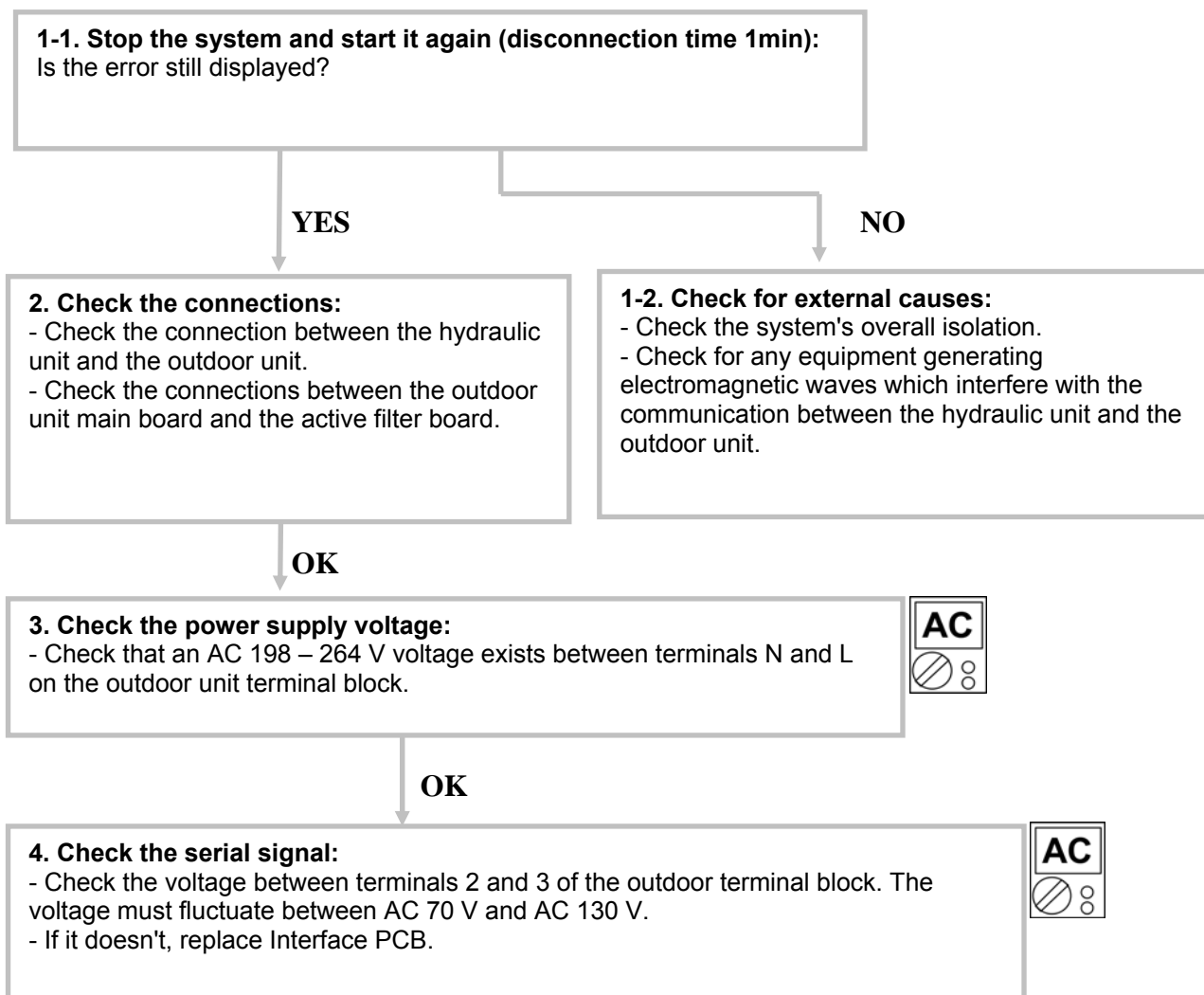

**Clear 4: Heat pump capacity signal error**

Hydraulic Unit LED: Green 4 flashes / Red 1 flash

Outdoor Unit LED: 22 flashes

Probable causes:

- Misconnection.
- Sensor failure.
- Interface PCB failure.

Check:

**1. Check connection interface PCB and Heat pump regulator PCB:**

- See if the connector has been disconnected.
- See if the connection is correct.
- Check for any damage on the sensor cable.

After solving the misconnection problem, switch the heat pump back on.

OK

**2. Check resistance value:**

3 pin of CN22 – M < 10Ω

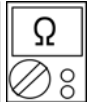

OK

**3. Replace interface PCB:**

If check point 1 and 2 do not improve the symptom, replace Interface PCB.

**Clear 5: Hydraulic Unit Heat exchanger thermistor error**

Hydraulic Unit LED: Green 4 flashes / Red 2 flashes

Outdoor Unit LED: 22 flashes

Probable causes:

- Misconnection.
- Sensor failure.
- Interface PCB failure.

Check:

**1. Check the sensor connection:**

- See if the connector has been removed
- See if the connection is correct
- Check for any damage on the sensor cable.

After solving the misconnection problem, switch the heat pump back on.

OK

**2. Remove the sensor and check its resistance value :**

- Check the resistance value.

Temperature (°C)	0	5	10	15	20	25	30	35	40	45	50
Resistance (kΩ)	176	134	103	80,3	62,9	49,7	39,6	31,7	25,6	20,8	17,1

- If the thermistor is faulty, replace it.



OK

**3. Check the electronic board voltage:**

- Make sure circuit diagram of hydraulic unit and check terminal voltage at thermistor (DC5.0V)

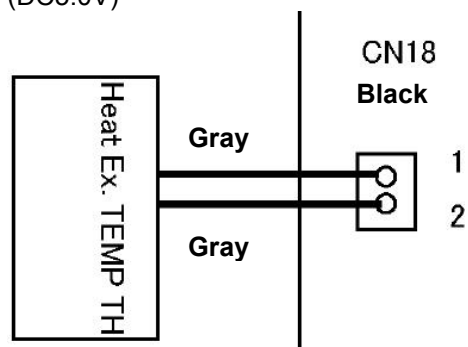

- If there is no voltage, replace Interface PCB.



**Clear 7: Discharge thermistor error**

Hydraulic Unit LED: Green 7 flashes / Red 1 flash

Outdoor Unit LED: 2 flashes

Probable causes:

- Misconnection.
- Sensor failure.
- Main PCB failure.

Check:

**1. Check the sensor connection:**

- See if the connector has been disconnected.
- See if the connection is correct.
- Check for any damage on the sensor cable.

After solving the misconnection problem, switch the heat pump back on.

OK

**2. Remove the sensor and check its resistance value:**

- Check the resistance value

Temperature (°C)	0	5	10	15	20	30	40	50
Resistance (kΩ)	168	130	101	79	63	40	26,3	17,8

Temperature (°C)	60	70	80	90	100	120
Resistance (kΩ)	12,3	8,7	6,3	4,6	3,4	2

- If the thermistor is faulty, replace it.

OK

**3. Check the electronic board voltage:**

Make sure circuit diagram of outdoor unit and check terminal voltage at thermistor (DC5.0V)

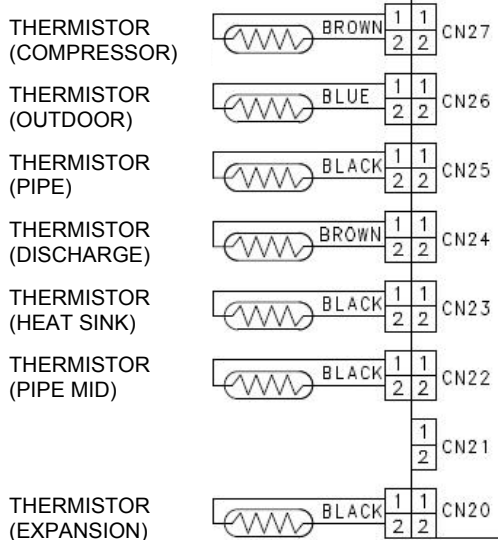

- If there is no voltage, replace Main PCB.



**Clear 8: Heat-exchange thermistor (outlet) error :**

Hydraulic Unit LED: Green 7 flashes / Red 3 flashes

Outdoor Unit LED: 4 flashes

Probable causes:

- Misconnection.
- Sensor fault.
- Main PCB failure.

Check:

**1. Check the sensor connection:**

- See if the connector has been disconnected.
- See if the connection is correct.
- Check for any damage on the sensor cable.

After solving the misconnection problem, switch the heat pump back on.

OK

**2. Remove the sensor and check its resistance value :**

- Check the resistancer value

Temperature (°C)	-10	-5	0	10	15	20	25	30
Resistance (kΩ)	27,5	20,9	16,1	12,4	9,73	7,67	6,1	3,95

- If the thermistor is faulty, replace it.



OK

**3. Check the electronic board voltage:**

- Make sure circuit diagram of outdoor unit and check terminal voltage at thermistor (DC5.0V)

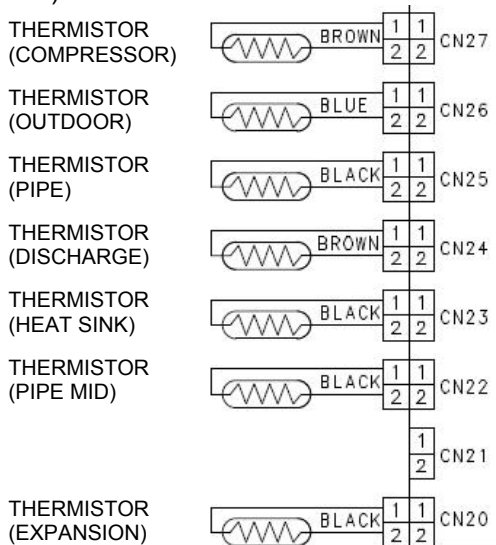

- If there is no voltage, replace Main PCB.



**Clear 9: Outdoor temperature thermistor error**

Hydraulic Unit LED: Green 7 flashes / Red 4 flashes

Outdoor Unit LED: 7 flashes

Probable causes:

- Misconnection.
- Sensor failure.
- Main PCB failure.

Check:

**1. Check the sensor connection :**

- See if the connector has been disconnected.
- See if the connection is correct.
- Check for any damage on the sensor cable.

After solving the misconnection problem, switch the heat pump back on.

OK

**2. Remove the sensor and check its resistance value :**

- Check the resistance value.

Temperature (°C)	-20	-10	-5	0	5	10	15	20	30	40	50	60	70
Resistance (kΩ)	115	62,3	46,6	35,2	26,9	20,7	16,1	12,6	7,97	5,18	3,45	2,36	1,65

- If the thermistor is faulty, replace it.

OK

**3. Check the electronic board voltage:**

- Make sure circuit diagram of outdoor unit and check terminal voltage at thermistor (DC5.0V)

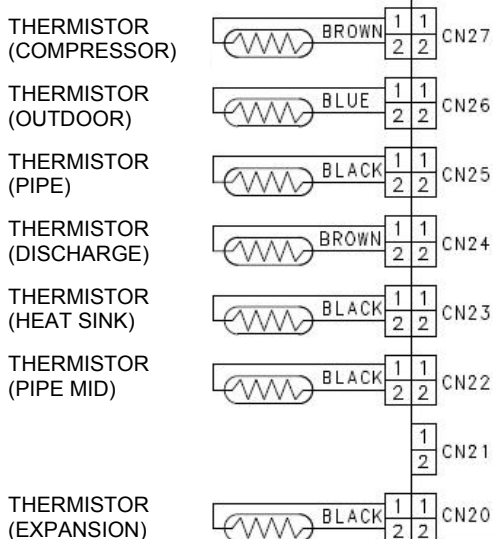

- If there is no voltage, replace Main PCB.



**Clear 10: Heat Sink Thermistor error**

Hydraulic Unit LED: Green 7 flashes / Red 7 flashes

Outdoor Unit LED: 9 flashes

Probable causes:

- Misconnection.
- Sensor failure.
- Main PCB failure.

Check:

**1. Check the sensor connection :**

- See if the connector has been disconnected.
- See if the connection is correct.
- Check for any damage on the sensor cable.

After solving the misconnection problem, switch the heat pump back on.

OK

**2. Remove the sensor and check its resistance value :**

- Check the resistance value.

Temperature (°C)	0	5	10	15	20	30	40	50
Resistance (kΩ)	15,8	12,2	9,5	7,5	5,9	3,78	2,50	1,69

Temperature (°C)	60	70	80	90	100	120
Resistance (kΩ)	1,17	0,83	0,6	0,44	0,33	0,19

- If the thermistor is faulty, replace it.



OK

**3. Check the electronic board voltage:**

- Make sure circuit diagram of outdoor unit and check terminal voltage at thermistor (DC5.0V)

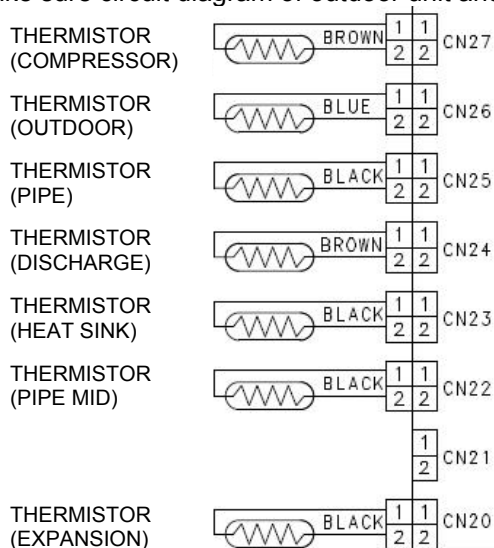

- If there is no voltage, replace Main PCB.





**Clear 11: Compressor thermistor error**

Hydraulic Unit LED: Green 7 flashes / Red 2 flashes

Outdoor Unit LED: 8 flashes

Probable causes:

- Misconnection.
- Sensor failure.
- Main PCB failure.

Check:

**1. Check the sensor connection:**

- See if the connector has been removed
- See if the connection is correct
- Check for any damage on the sensor cable.

After solving the misconnection problem, switch the heat pump back on.

OK

**2. Remove the sensor and check its resistance value :**

- Check the resistance value.

Temperature (°C)	0	5	10	15	20	30	40	50
Resistance (kΩ)	168	130	101	79	63	40	26,3	17,8

Temperature (°C)	60	70	80	90	100	120
Resistance (kΩ)	12,3	8,7	6,3	4,6	3,4	2

- If the thermistor is faulty, replace it.



OK

**3. Check the electronic board voltage:**

- Make sure circuit diagram of outdoor unit and check terminal voltage at thermistor (DC5.0V)

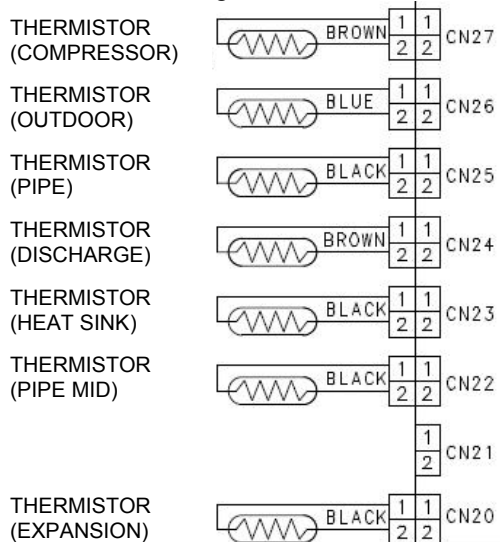

- If there is no voltage, replace Main PCB.



**Clear 12: Heat-exchange thermistor (intermediate) error**

Hydraulic Unit LED: Green 7 flashes / Red 3 flashes

Outdoor Unit LED: 5 flashes

Probable causes:

- Misconnection.
- Sensor failure.
- Main PCB failure.

Check:

**1. Check the sensor connection:**

- See if the connector has been disconnected.
- See if the connection is correct.
- Check for any damage on the sensor cable.

After solving the misconnection problem, switch the heat pump back on.

OK

**2. Remove the sensor and check its resistance value :**

- Check the resistance value

Temperature (°C)	-10	-5	0	10	15	20	25	30
Resistance (kΩ)	27,5	20,9	16,1	12,4	9,73	7,67	6,10	3,95



- If the thermistor is faulty, replace it.

OK

**3. Check the electronic board voltage:**

- Make sure circuit diagram of outdoor unit and check terminal voltage at thermistor (DC5.0V)

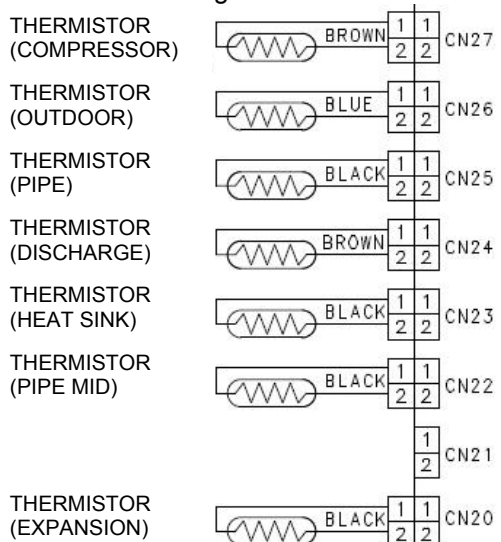

- If there is no voltage, replace Main PCB.

**Clear 14: Expansion valve thermistor error**

Hydraulic Unit LED: Green 7 flashes / Red 8 flashes

Outdoor Unit LED: 6 flashes

Probable causes:

- Misconnection.
- Sensor failure.
- Main PCB failure.

Check:

**1. Check the sensor connection:**

- See if the connector has been removed
- See if the connection is correct
- Check for any damage on the sensor cable.

After solving the misconnection problem, switch the heat pump back on.

OK

**2. Remove the sensor and check its resistance value :**

- Check the resistance value.

Temperature (°C)	0	5	10	15	20	30	40	50
Resistance (kΩ)	168	130	101	79	63	40	26,3	17,8

Temperature (°C)	60	70	80	90	100	120
Resistance (kΩ)	12,3	8,7	6,3	4,6	3,4	2

- If the thermistor is faulty, replace it.



OK

**3. Check the electronic board voltage:**

- Make sure circuit diagram of outdoor unit and check terminal voltage at thermistor (DC5.0V)

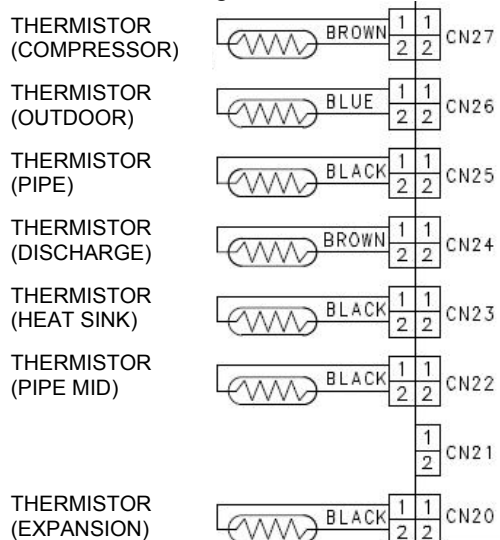

- If there is no voltage, replace Main PCB.



**Clear 15: Current trip (permanent stoppage)**

Hydraulic Unit LED: Green 9 flashes / Red 4 flashes

Outdoor Unit LED: 13 flashes

Probable causes:

- Connection failure.
- Outdoor Heat Exchanger clogged.
- Outdoor Fan operation failure.
- Compressor failure.
- Main PCB failure.

Check:

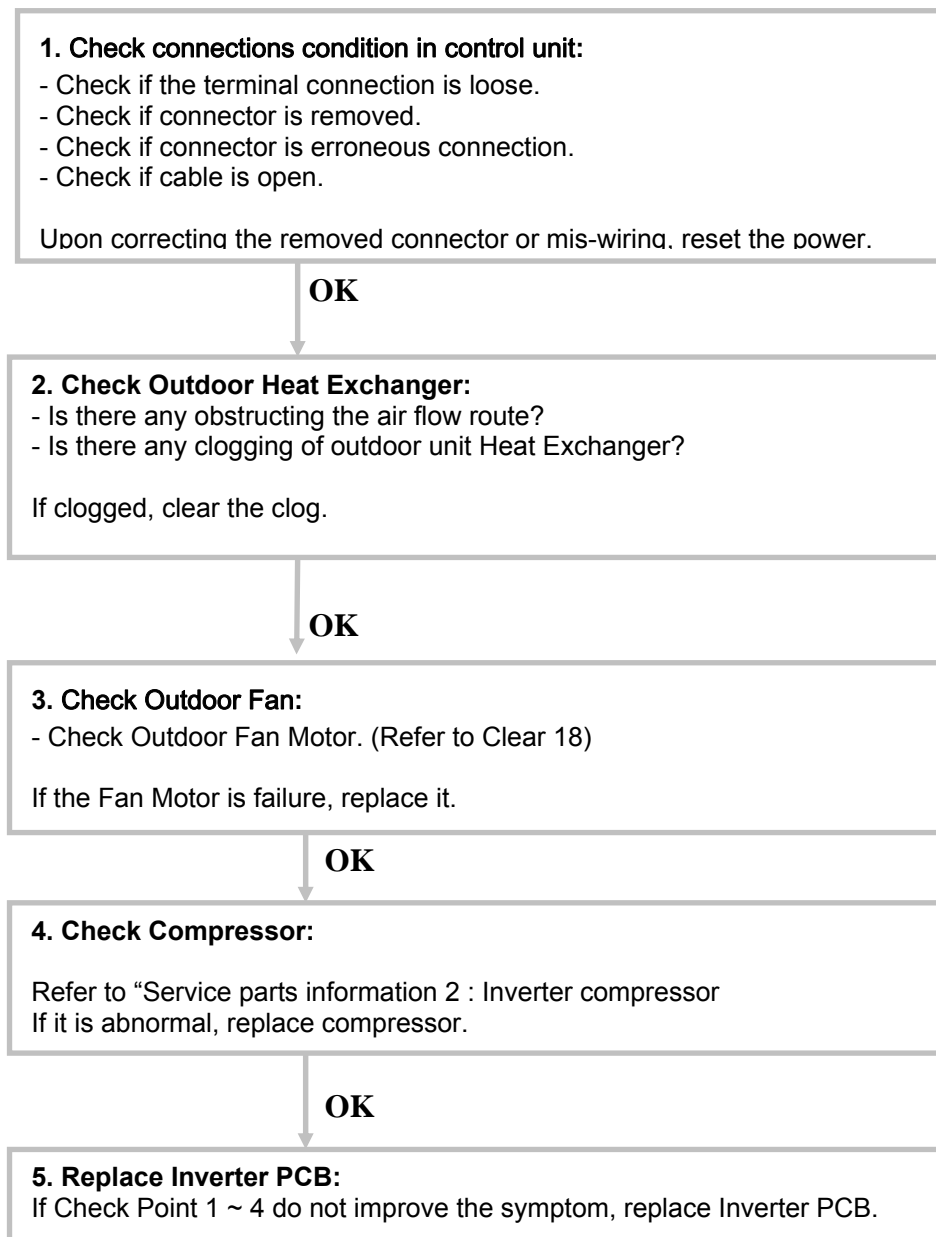

**Clear 17: Compressor startup error (permanent stoppage)**

Hydraulic Unit LED: Green 9 flashes / Red 5 flashes

Outdoor Unit LED: 15 flashes

Probable causes:

- Misconnection of the various electrical components.
- Main PCB failure.
- Compressor failure.

Check:

**1. Check connections condition in control unit:**

- Check if the terminal connection is loose.
- Check if connector is removed.
- Check if connector is erroneous connection.
- Check if cable is open.

Upon correcting the removed connector or mis-wiring, reset the power.

↓  
**OK**

**2. Check Compressor:**

Refer to "Service parts information 2 : Inverter compressor  
If it is abnormal, replace compressor.

↓  
**OK**

**3. Replace the electronic board :**

- If steps 1 and 2 do not solve the problem, replace Inverter PCB.

## Split system (Single phase and 3-phase type)

### Clear 18: Fan motor error (permanent stoppage)

Hydraulic Unit LED: Green 9 flashes / Red 7 flashes

Outdoor Unit LED: 16 flashes (fan 1), 17 flashes (fan 2)

#### Probable causes:

- Fan motor failure.
- Motor protection.
- Main PCB failure.

#### Check:

##### 1. Check fan rotation:

- Switch off the heat pump and rotate the fan manually.
- If the fan or bearings are faulty, replace them.

OK

##### 2. Check the ambient temperature around the motor:

- Check excessively high temperature around the fan.

Wait until the temperature comes down again and switch the fan back on.

OK

##### 3. Check the main board output voltage:

- On the outdoor unit, check the output voltage (DC) of the following connectors:



Terminals	Voltage
1 (red)/ 3 (black)	300~390V
4 (white)/3 (black)	15 ±2V

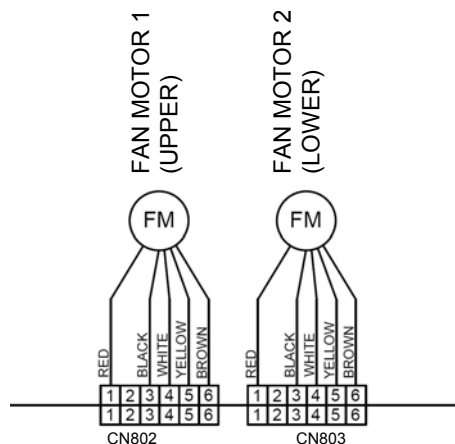

If the voltage is incorrect, replace Main PCB.

**Clear 20: Inverter error**

Hydraulic Unit LED: Green 6 flashes / Red 3 flashes

Outdoor Unit LED: 18 flashes

Probable causes:

- Connection failure.
- Main PCB failure.

Check:

**1. Check connections in control unit:**

- Check if the terminal connection is loose.
- Check if connector is removed.
- Check if connector is erroneous connection.
- Check if cable is open.

Upon correcting the removed connector or mis-wiring, reset the power.

OK

**2. Replace Main PCB :**

If Check Point 1 does not improve the symptom, replace Main PCB.

## Split system (Single phase and 3-phase type)

---

### **Clear 21: active filter error (only for single phase type)**

Hydraulic Unit LED: Green 6 flashes / Red 4 flashes

Outdoor Unit LED: 19 flashes

#### Probable causes:

- Connection failure.
- Active filter module failure.
- Main PCB failure.

#### Check:

**1. Check connections in control unit:**

- Check if the terminal connection is loose.
- Check if connector is removed.
- Check if connector is erroneous connection.
- Check if cable is open.

Upon correcting the removed connector or mis-wiring, reset the power.

**OK**

**2. Replace Active Filter Module and Main PCB :**

If Check Point 1 does not improve the symptom, replace Main PCB and Active Filter Module and execute the checkoperation again.



**Clear 22: Discharge temperature protection (permanent stoppage)**

Hydraulic Unit LED: Green 10 flashes / Red 1 flashes

Outdoor Unit LED: 11 flashes

Probable causes:

- Valve is close.
- EEV failure.
- Gas leak, less.
- Discharge Thermistor failure.
- Outdoor Fan operation failure.
- Outdoor Heat Exchanger clogged.

Check:

Cooling mode

**1. Check if gas valve is open:**

If it is not open, open it and check the operation.

OK

**2. Check EEV and Strainer:**

Are EEV and Strainer open?

If EEV or Strainer is defective, replace it.

OK

Heating mode

**1. Check if liquid valve is open:**

If it is not open, open it and check the operation.

OK

**2. Check EEV and Strainer:**

Are EEV and Strainer open?

If EEV or Strainer is defective, replace it.

OK

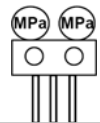

**3. Check if gas leak or less gas:**

Measure gas pressure, if there is a leak, correct it.

If recharging refrigerant, make sure to perform vacuuming and recharge the specified amount.

OK

**4. Check Discharge Pipe Thermistor:**

- Is it on the holder?
- Is there a cable pinched?

Check characteristics of thermistor (Refer to Clear 7), If defective, replace the thermistor

OK

**5. Check Outdoor Heat Exchanger:**

- Is there any obstructing the air flow route?
- Is there any clogging of outdoor unit Heat Exchanger?

If clogged, clear the clog.

OK

**6. Check Outdoor Fan:**

Check Outdoor Fan Motor. (Refer to Clear 18)

If the Fan Motor is failure. replace it.

**Clear 24: Pressure sensor error**

Hydraulic Unit LED: Green 8 flashes / Red 6 flashes

Outdoor Unit LED: 3 flashes

Probable causes:

- Connector connection failure.
- Pressure Sensor failure.
- Main PCB failure.

Check:

**1. Check connection of the Pressure Sensor:**

- Check if the terminal connection is loose.
- Check if connector is removed.
- Check if connector is erroneous connection.
- Check if cable is open.

Upon correcting the removed connector or mis-wiring, reset the power.

OK

**2. Check output voltage of Main PCB :**

Check voltage of Main PCB (Measure at Main PCB side connector)

1 pin(Red) - 3 pin(Black) DC5V +/- 5%

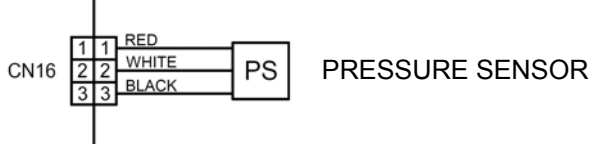

If the voltage is not correct, replace Main PCB.



OK

**3. Check output voltage of Pressure Sensor**

Check voltage of Main PCB (Measure at Main PCB side connector)

2 pin(White) - 3 pin(Black) Voltage is refer to the following graph.

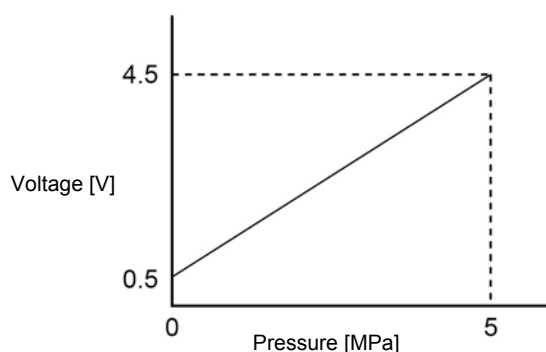

If the voltage is not correct, replace Pressure Sensor.



**Clear 25: Compressor temperature protection (permanent stoppage)**

Hydraulic Unit LED: Green 10 flashes / Red 3 flashes

Outdoor Unit LED: 12 flashes

Probable causes:

- Valve is close.
- EEV failure.
- Gas leak, less.
- Compressor Thermistor failure.
- Outdoor Fan operation failure.
- Outdoor Heat Exchanger clogged.

Check:

Cooling mode

Heating mode

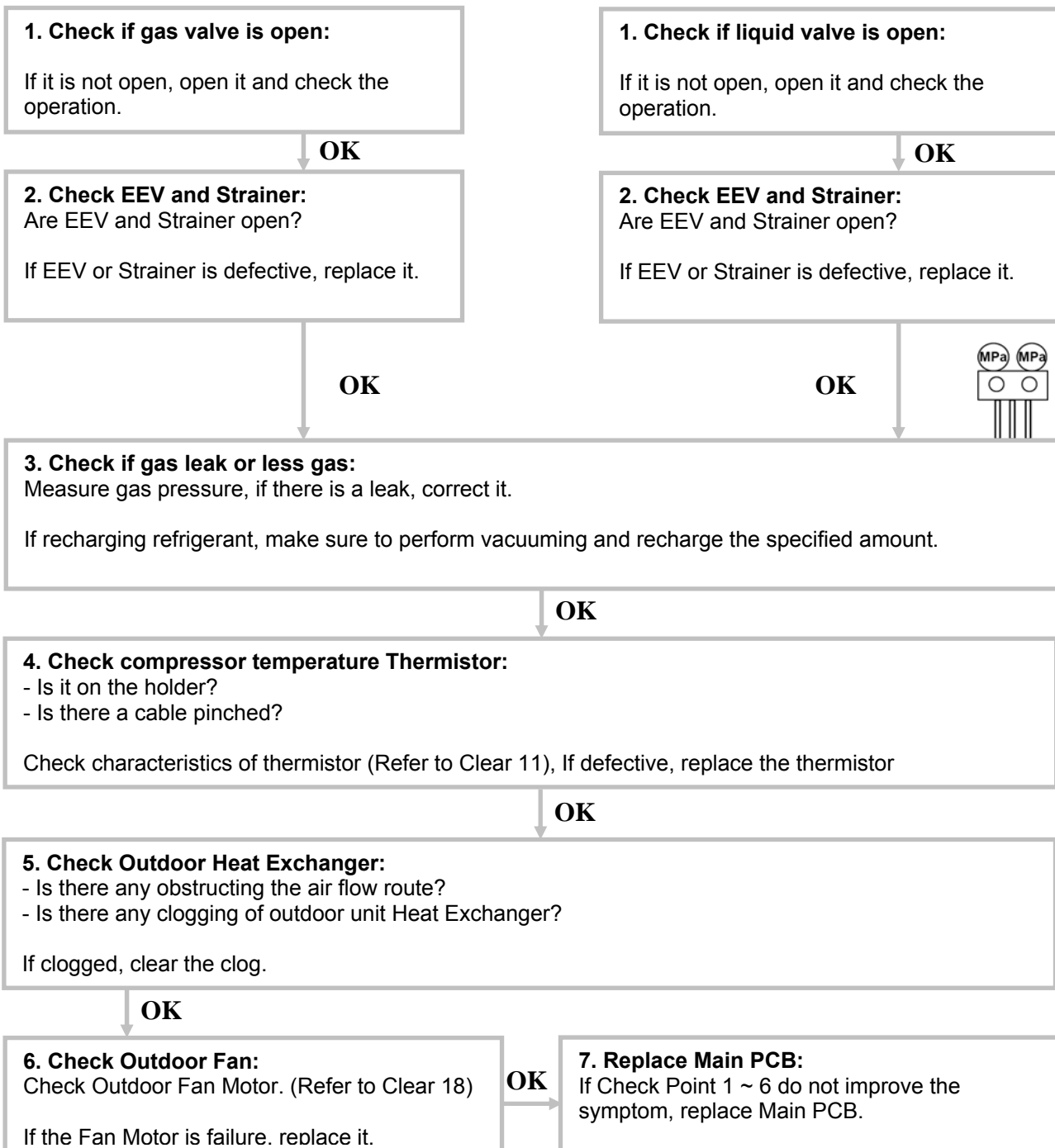

**Clear 26: Low pressure abnormal**

Hydraulic Unit LED: Green 10 flashes / Red 5 flashes

Outdoor Unit LED: 20 flashes

Probable causes:

- Connector connection failure.
- Pressure Sensor failure.
- Main PCB failure.
- Gas leak, less.

Check:

**1. Check connection of the Pressure Sensor:**

- Check if the terminal connection is loose.
- Check if connector is removed.
- Check if connector is erroneous connection.
- Check if cable is open.

Upon correcting the removed connector or mis-wiring, reset the power.

OK

**2. Check output voltage of Main PCB :**

Check voltage of Main PCB (Measure at Main PCB side connector)

1 pin(Red) - 3 pin(Black) DC5V +/- 5%

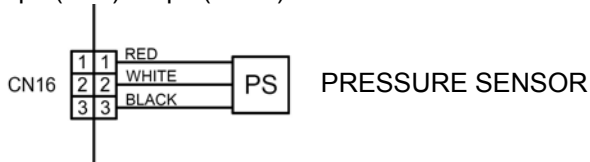

If the voltage is not correct, replace Main PCB.



OK

**3. Check if gas leak or less gas**

Measure Gas pressure, if there is a leak, correct it.

If recharging refrigerant, make sure to perform vacuuming and recharge the specified amount.

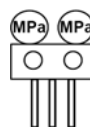

OK

**4. Replace Pressure Sensor**

If Check Point 1 ~ 3 do not improve the symptom, replace Pressure Sensor.

**Clear 27: P.F.C. error (only for 3-phase type)**

Hydraulic Unit LED: Green 6 flashes / Red 4 flashes

Outdoor Unit LED: 19 flashes

Probable causes:

- Connector connection failure.
- Main PCB failure.
- PFC PCB failure.

Check:

**1. Check connections of between Main PCB and PFC PCB:**

- Check if the terminal connection is loose.
- Check if connector is removed.
- Check if connector is erroneous connection.
- Check if cable is open.

Upon correcting the removed connector or mis-wiring, reset the power.

OK

**2. Check output voltage of Main PCB :**

Check voltage of Main PCB (Measure at Main PCB side connector)

1 pin(brown) - 2 pin(Red) DC5V +/- 5%

If the voltage is not correct, replace Main PCB.



OK

**3. Replace PFC PCB**

If Check Point 1, 2 do not improve the symptom, replace PFC PCB.

**Clear 33: Detection of compressor position error (permanent stoppage)**

Hydraulic Unit LED: Green 9 flashes / Red 5 flashes

Outdoor Unit LED: 14 flashes

Probable causes:

- Misconnection.
- Main PCB failure.

Check:

**1. Check connections condition in control unit:**

- Check if the terminal connection is loose.
- Check if connector is removed.
- Check if connector is erroneous connection.
- Check if cable is open.

Upon correcting the removed connector or mis-wiring, reset the power.

**OK**



**2. Replace the electronic board :**

- If steps 1 does not solve the problem, replace Main PCB.

## 2.2.2 Failures With No Error Code

### **Clear 35: No voltage on Hydraulic Unit**

Probable causes:

- Power supply fault.
- External causes.
- Faulty electrical components.

Check:

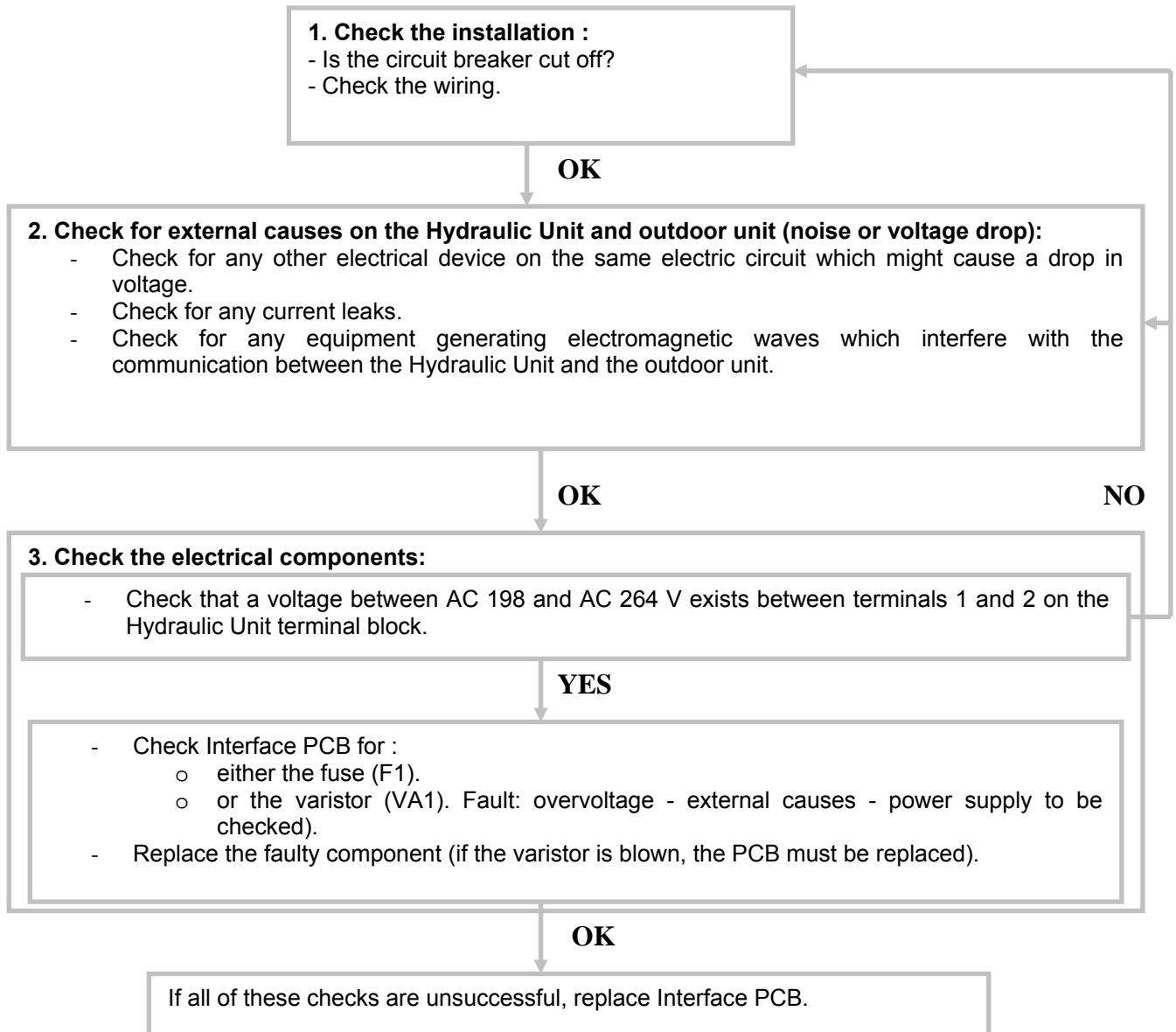

**Clear 36: No voltage on outdoor unit**

Probable causes:

- Power supply fault.
- External cause.
- Faulty electrical components.

Check:

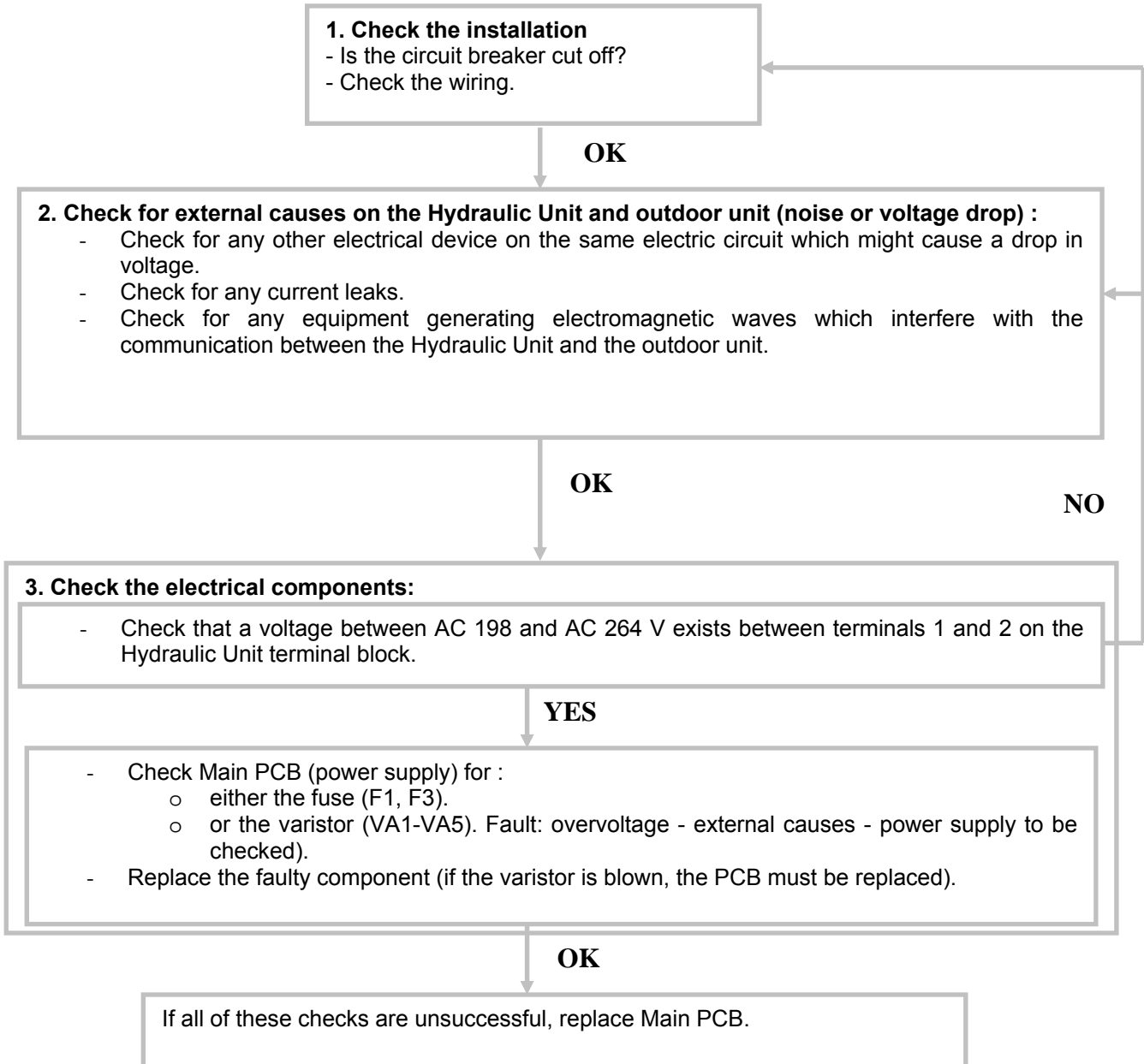



**Clear 38: No heat**

Probable causes:

- Hydraulic Unit error.
- Outdoor unit error.
- Influence from the outdoor environment.
- Misconnections of connectors and cables.
- Refrigeration system fault (not enough gas, clogging, dirty filters).

Check:

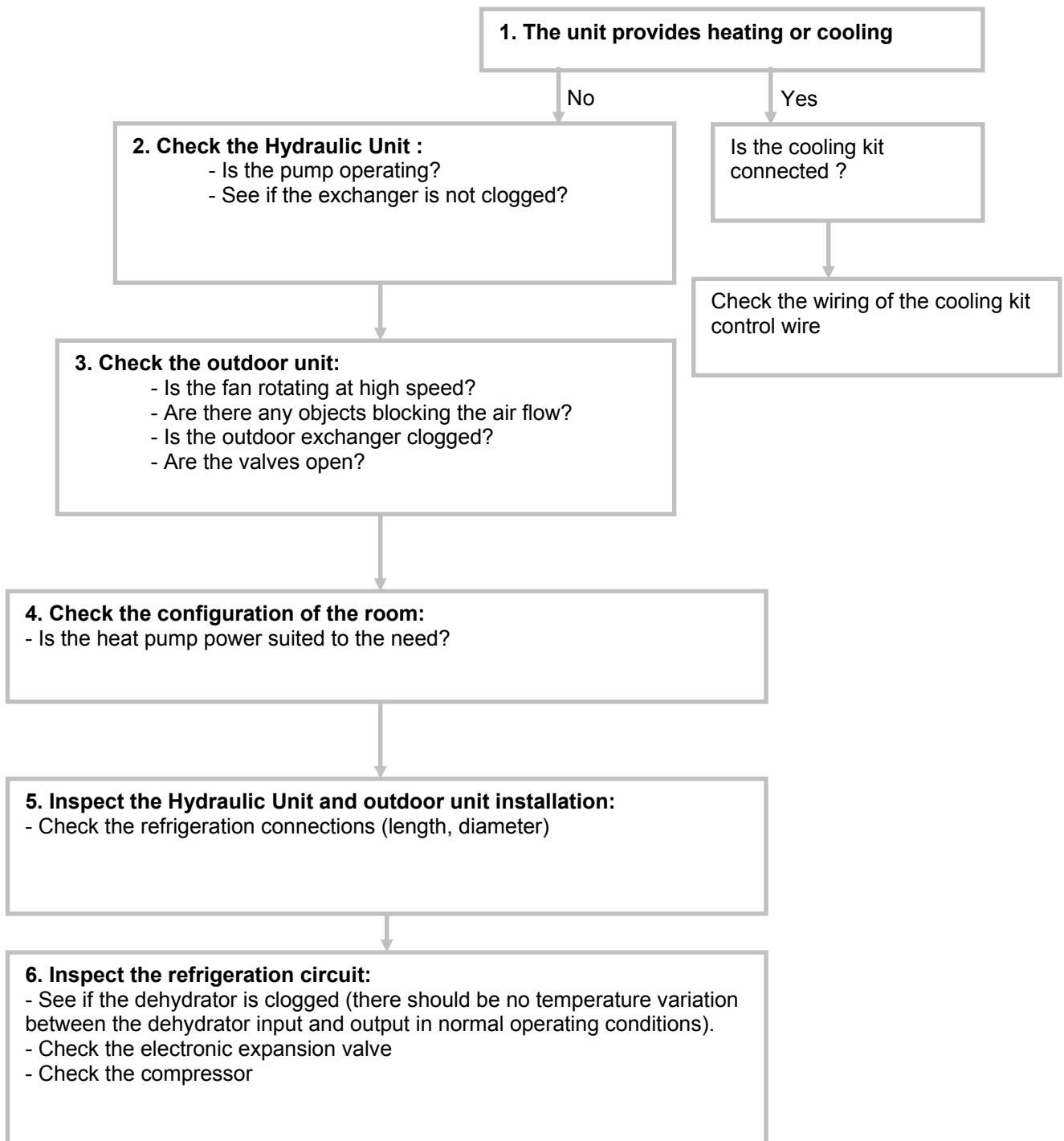

**Clear 39: Abnormal noise**

Probable causes:

- Abnormal installation (outdoor)
- Fan failure
- Compressor failure.

Checks:

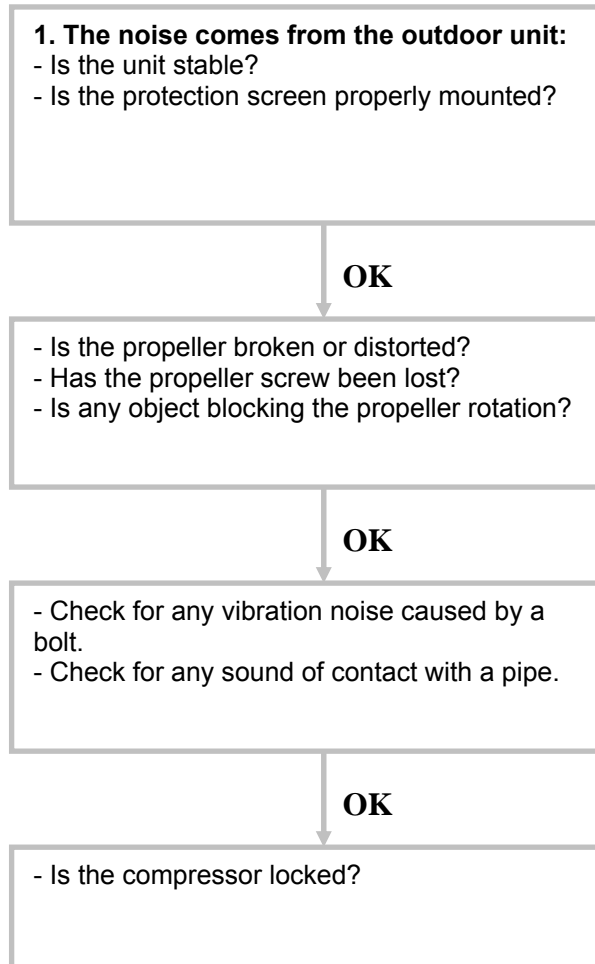

## 2.3 Sensor Values

### 2.3.1 Outdoor Unit Temperature Sensors

#### Outdoor Heat Exchanger (outlet), Outdoor Heat Exchanger (middle)

Temperature (°C)	-10	-5	0	10	15	20	25	30
Resistance value (kΩ)	27,5	20,9	16,1	12,4	9,73	7,67	6,1	3,95

#### Outdoor Discharge Pipe / Compressor / Expansion valve inlet

Temperature (°C)	0	5	10	15	20	30	40	50	60
Resistance value (kΩ)	168	130	101	79	63	40	26,3	17,8	12,3

Temperature (°C)	70	80	90	100	120
Resistance value (kΩ)	8,7	6,3	4,6	3,4	2

#### Outdoor Temperature

Temperature (°C)	-20	-10	-5	0	5	10	15	20	30
Resistance value (kΩ)	115	62,3	46,6	35,2	26,9	20,7	16,1	12,6	7,97

Temperature (°C)	40	50	60	70
Resistance value (kΩ)	5,18	3,45	2,36	1,65

#### Heat sink

Temperature (°C)	0	5	10	15	20	30	40	50	60
Resistance value (kΩ)	15,8	12,2	9,5	7,5	5,9	3,78	2,50	1,69	1,17

Temperature (°C)	70	80	90	100	110	120
Resistance value (kΩ)	0,83	0,60	0,44	0,33	0,25	0,19

### 2.3.2 Hydraulic Unit Temperature Sensors

#### Heat Exchanger (Condensing sensor)

Temperature (°C)	0	5	10	15	20	25	30	35	40	45	50
Resistance value (kΩ)	176	134	103	80,3	62,9	49,7	39,6	31,7	25,6	20,8	17,1

#### Outdoor sensor

Temperature (°C)	-20	-15	-10	-5	0	5	10	15	20
Resistance value (kΩ)	7,60	5,85	4,60	3,60	2,85	2,30	1,85	1,50	1,20

Temperature (°C)	25	30	35	40	45
Resistance value (kΩ)	1	0,83	0,70	0,58	0,48

#### Heat pump flow and return sensor – DHW and heating zone 2 sensor – Swimming pool return sensor

Temperature (°C)	-15	-10	-5	0	5	10	15	20	25
Resistance value (kΩ)	72,5	55	42	32,5	25	20	15,7	12,5	10

Temperature (°C)	30	35	40	45	50	55	60	65	70
Resistance value (kΩ)	8	6,5	5	4	3,5	3	2,5	2	1,7

## 2.4 Service parts information

### 2.4.1 Service parts information 1 : Compressor

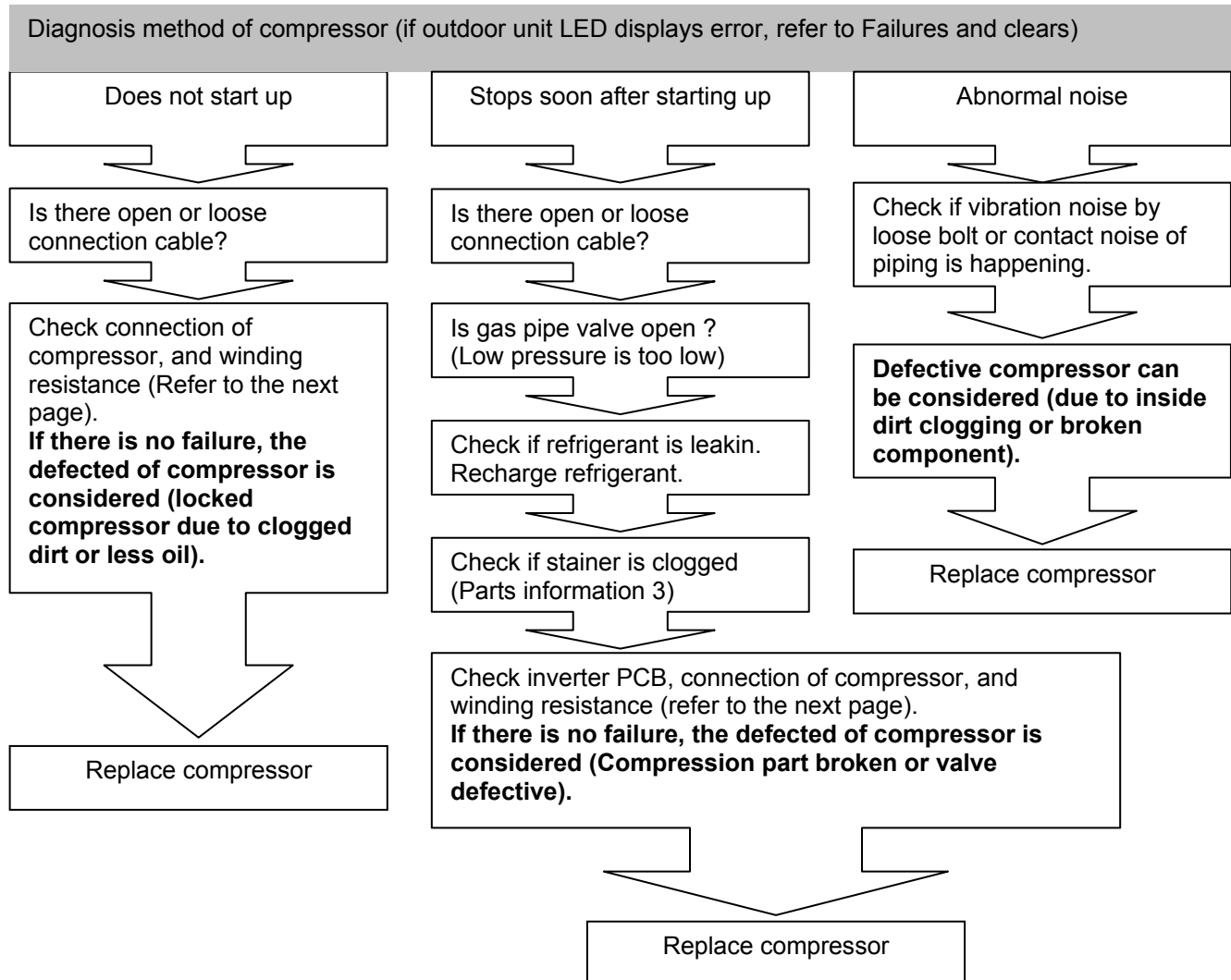

## 2.4.2 Service parts information 2 : Inverter compressor

### Check point 1 : Check connection

Check terminal connection of compressor  
(Loose or incorrect wiring)

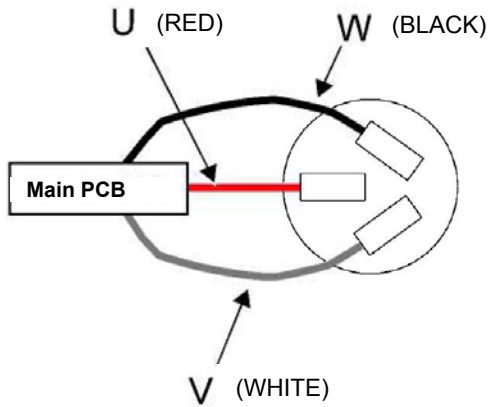

### Only for 3-phase type :

Check connection of inverter PCB  
(Loose or incorrect wiring)

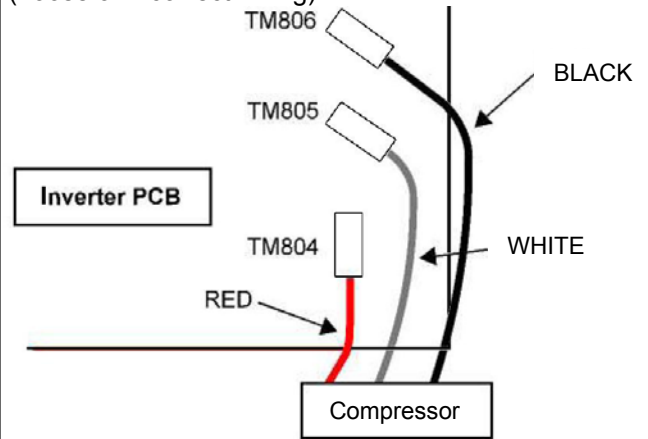

### Check point 2 : check winding resistance

Check winding resistance on each terminal

If the resistance value is 0Ω or infinite, replace compressor.

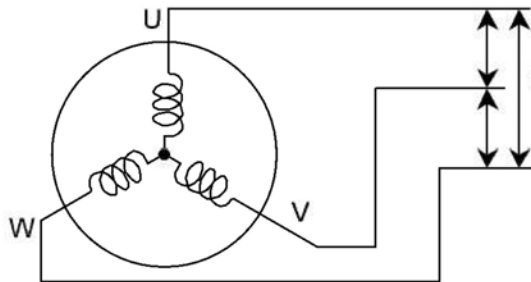

Resistance value :

- 0.24 Ω (at 20°C) for single phase type
- 0.79 Ω (at 20°C) for 3-phase type



### Check point 3 : replace Main PCB

If check point 1 and 2 do not improve the symptom, replace Main PCB.

### 2.4.3 Service parts information 3 : Outdoor unit electronic expansion valve (EEV, EEV(INJ))

#### Check point 1 : Check connection

Check connection of connector  
(Loose connector or open cable)

##### Single phase :



##### 3-phase :



#### Check point 2 : Check coil of EEV

Remove connector, check each winding resistance of coil.

Read wire	Resistance value
White-Red	46Ω +/- 4Ω at 20°C
Yellow-Red	
Orange-Red	
Blue-Red	

If resistance value is abnormal, replace EEV.

#### Check point 3 : Check voltage from main PCB

Remove connector and check voltage (DC12V)  
If it does not appear, replace Main PCB.



#### Check point 4 : Check noise at start up

Turn on power and check operation noise.

If an abnormal noise does not show, replace Main PCB.

#### Check point 5 : Check opening and closing operation of valve

When valve is closed, it has a temp. (Add period) difference between inlet and outlet.

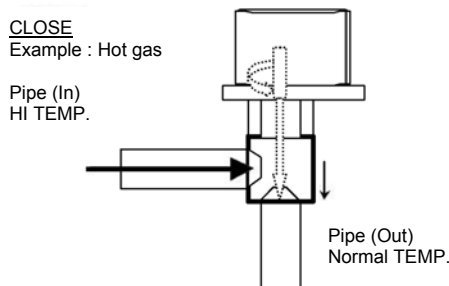

If it is open, it has no temp. (Add period) difference between inlet and outlet.

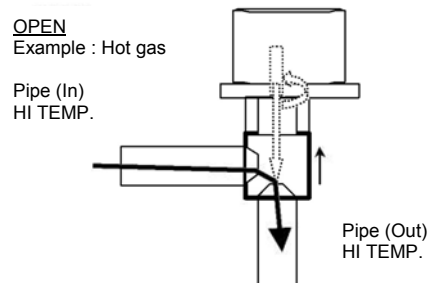

There is no refrigerant flow coming to EEV(INJ) while the liquid injection is inactive. Check whether the liquid injection is active before executing check point 5 for EEV(INJ).

#### Check point 6 : Check stainer

Stainer normally does not have temperature difference between inlet and outlet as shown in 1, but if there is a difference as shown in 2, there is a possibility of inside clogged. In this case, replace stainer.

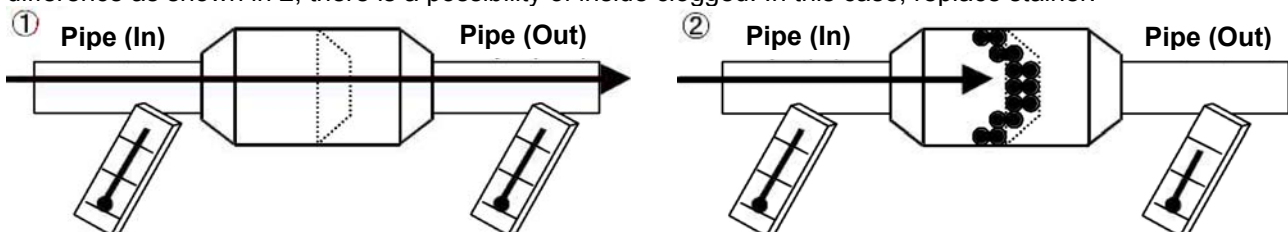

## 2.4.4 Service parts information 4 : Outdoor unit solenoid valve (SV)

### Check point 1 : Check connections

Check connection of connector  
(Loose connector or open cable)

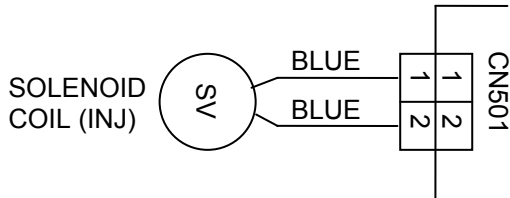

### Check point 2 : Check solenoid coil

Remove connector and check if coil is open  
(normal resistance value of each coil : 1495+/-7%)

**If resistance value is abnormal, replace solenoid coil.**



### Check point 3 : Check voltage from main PCB

Remove connector and check the voltage  
(AC230V).

**If the voltage does not appear, replace Main PCB.**

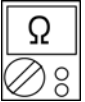

### Check point 4 : check opening and closing operation valve

Depending on the injection activity, check if valve is operating normally.

(When valve opens, there is no temperature difference between inlet and outlet)

Injection is inactive  
Pipe (In) TEMP. HI.  
Pipe (Out) TEMP. Normal

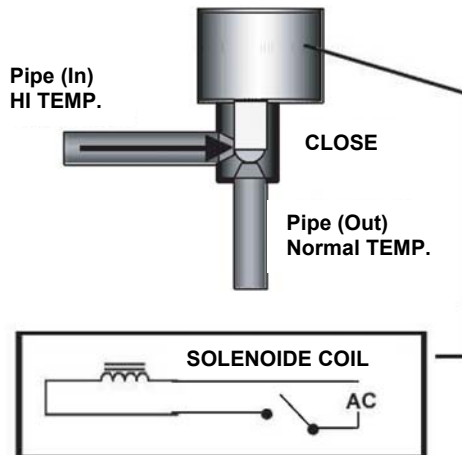

Injection is active

Pipe (In) TEMP.= Pipe (Out) TEMP.

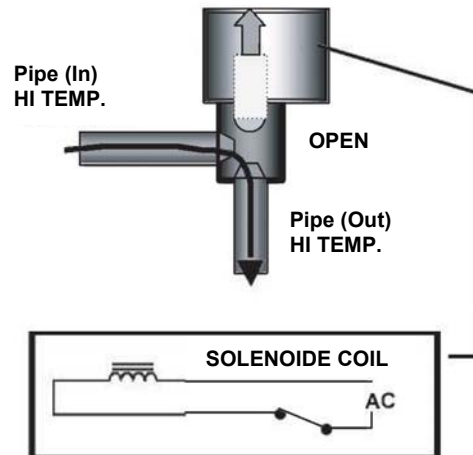

- If the valve closes by removing the connector of the valve which does not close, it is considered to be Main PCB failure. Replace Main PCB.

- If it does not close by removing connector, there is a possibility of (1) clogging by dirt, or (2) deformation by the heat at the time of solenoid valve installation. In this case, replace solenoid valve.

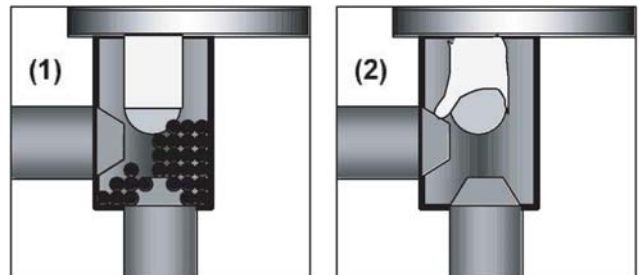

## 2.5 Operating Limits

HEAT PUMP	Single phase		3-phase		
	112	140	112	140	160
Min/max OT in heat mode (°C) <sup>***</sup>	-25/35				
Heating floor maximum water temperature (°C)	45				
LT radiator maximum water temperature (°C)	60				
Min/max OT in cooling mode(°C)	8/43				
Cooling floor minimum water temperature (°C)	18				
Fan coil minimum water temperature (°C)	8				
Water circuit max pressure (Bar)	3				
Maximum flow rate (l/h)	2340	2920	2340	2920	3290
Minimum flow rate (l/h)	1170	1460	1170	1460	1650
Refrigerant circ max pressure (kPa)	4,2				
Min delta T (°C)	4				
Max delta T (°C)	8				
Outdoor unit Noise level 1 (dBA)*	55	56	53	55	56
Outdoor unit Noise level 5 (dBA)**	39	41	39	41	42
Outdoor unit air flow rate (m <sup>3</sup> /h)	3100 x 2			3450 x 2	

\* Acoustic pressure level reading at 1m, in open field, on a reflecting plane.

\*\* Acoustic pressure level reading at 5m, in open field, on a reflecting plane.

\*\*\* When the outdoor temperature continuously exceeds 35°C, DHW heating is done by the water heater heating element.



### 3 Failures

#### 3.1 Hydraulic, Electric and Refrigeration Systems

##### 3.1.1 Hydraulic System

If the installation is fitted with a heating floor, the most common failures are those listed below:

FAILURE CASES	CONSEQUENCES	SOLUTIONS		APPLIED BY
1- Clogged filter* or sludge in system	Flow pressure too high	clean filter or desludge		Installer
	$\Delta T$ too high (>7)	clean filter or desludge		Installer
2- Pump out of order	Zero flow pressure	change pump with warranty if pump is faulty		Service station
	current too high (rotor locked)	change pump with warranty if pump is faulty		Service station
	zero current (winding cut off)	change pump with warranty if pump is faulty		Service station
	pump stuck	release with a screwdriver		Installer
3-Leak	Low level in expansion vessel	On collector, isolate heating circuits to determine which heating circuit is perforated.	Pipe leak. Pipe under warranty if faulty	Service station
			Leak in heating circuit. Floor again.	Installer
4- Clogged heating circuit (crushed pipe)	Very high difference between floor flow/return temp	On collector, check heating circuit flow/return temps (infrared thermometer)	Clear with test pump	Service station
		If no clogged heating circuit, check for crushing with infrared camera	Call the installer's or floor coverer's responsibility into question	
5- Misbalance	Very high difference between floor flow/return temp	Rebalance		Installer
6- Floor undersized or charge losses too high	Very high difference between floor flow/return temp	On collector, check heating circuit flow/return temps (infrared thermometer)	Call the installer's responsibility into question	Installer or Service station

\* Not required and not shown on the device.

### 3.1.2 Electrical System

#### Outdoor Unit Overvoltage

Check for possible causes in the list below (this list is not exhaustive):

- Problem with the compressor
- Main board
- Faulty power relay

**Steps to be followed before performing any work on the Inverter module:**

- First switch off the system using the circuit breaker at the head of the line.
- Remove the unit cover and then remove the Inverter module cover.
- Measure the voltage at the condenser terminals. You should find a value of 5 Vdc or less.

#### Inspection of the Power Transistor Module (Main board)

Disconnect the compressor relay and the condenser connection. Measure the resistance value at the points shown on the illustration, and then compare the values observed with those in the table.

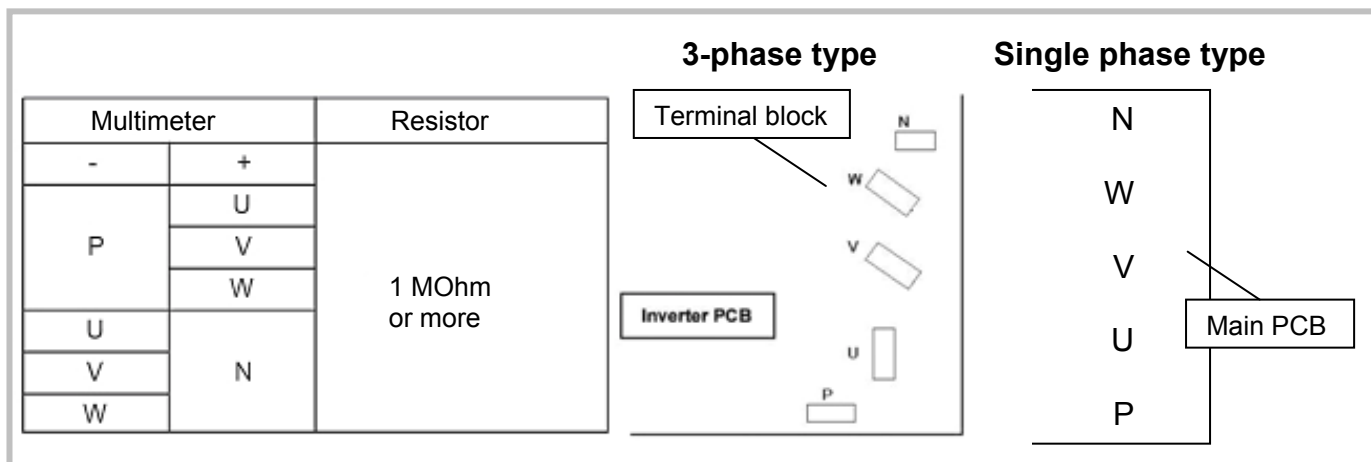

### 3.1.3 Refrigeration System

#### Unit produces no heat

The unit remains in continuous scanning mode.

#### Initial checks:

Check the settings

Are the data sent by the user interface received by the heat pump?

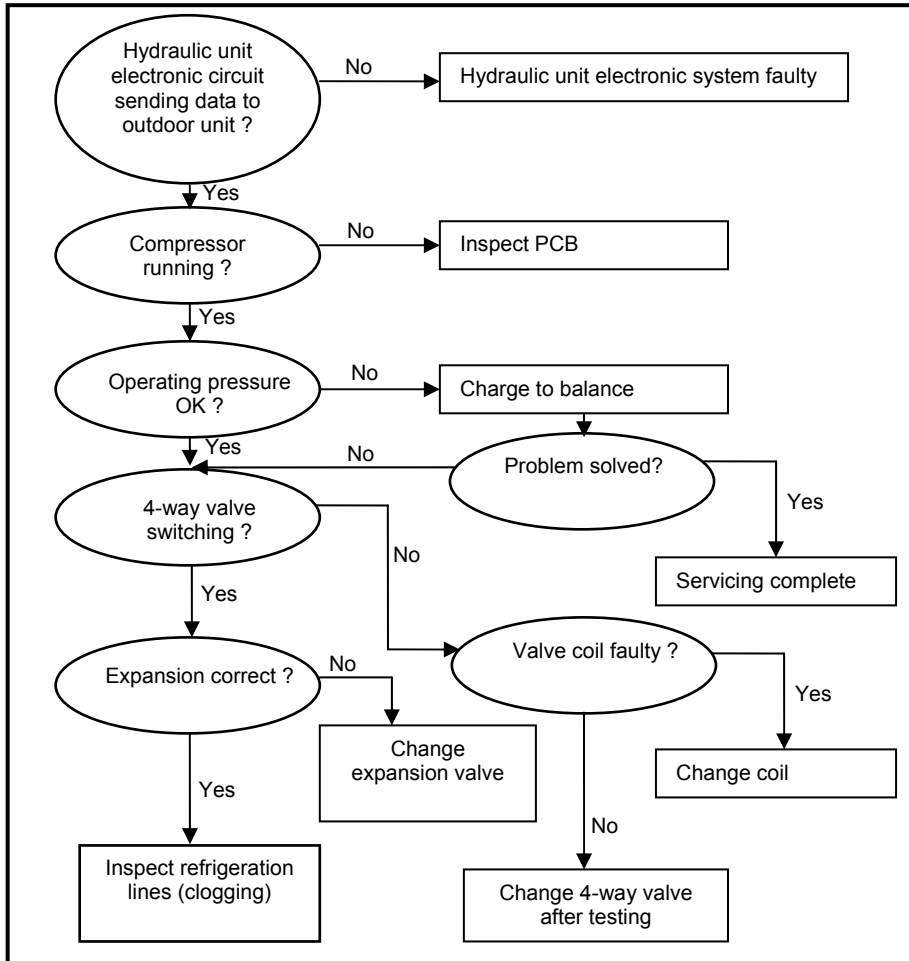

**Outdoor unit does not defrost**

- Is condensation drain properly discharged (outdoor unit directly on the ground)?
- Are the auxiliaries powered?
- In boiler backup mode, is the boiler authorized?
- In very cold areas, a fusing resistance value is recommended.
  - Is the installation regularly subject to micro-outages of power (frequent outages on the mains power system may also cause defrosting problems)?
  - Is there a peak day clearing (EJP) outage on the installation?
- Does the heat pump regularly switch to high pressure safety mode?

If this occurs at low temperatures (< 5 °C), we recommend checking that the water pump is operating properly.

- Is the charge correct (refer to the temperature/pressure curve)?
  - Insufficient charging will result in frequent icing.
  - Overcharging will result in frequently switching to HP safety mode.

(If you still have doubts as to the charge, perform the charging with an electronic scale).

- Outdoor unit defrosting is controlled by the exchanger sensor and the controller board.

If the defrost sensor is not iced up while the rest of the exchanger is, then:

- ⇒ Move the sensor between the exchanger blades to a place where the exchanger is iced up.
- ⇒ If all these points have been checked, replace the outdoor controller board.

**Note:**

Outdoor unit defrosting is controlled by the exchanger sensor and the controller board. If no frosting is observed and no anomaly is otherwise noted, the sensor and board must be inspected and the faulty part will have to be replaced.

**Defrosting**

- a. Defrost beginning conditions

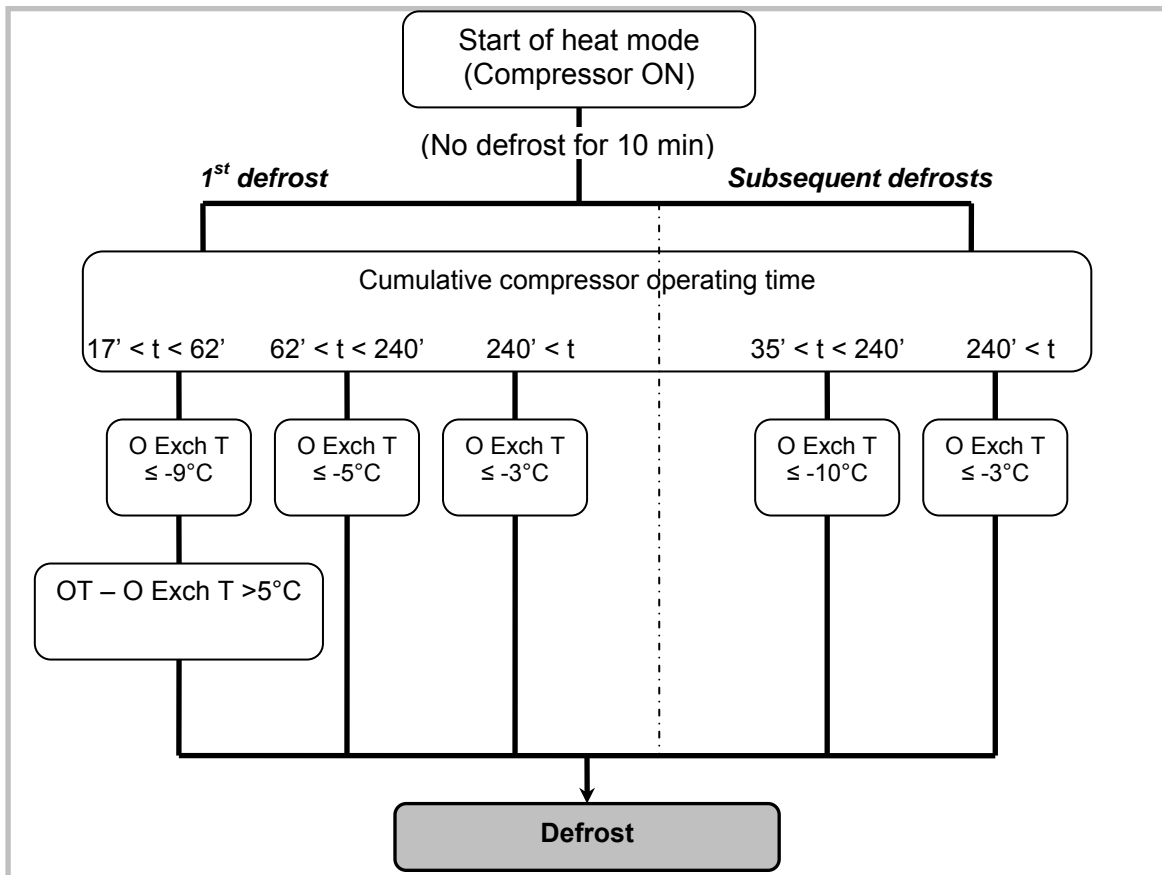

O Exch T : outdoor unit exchanger temperature  
 OT : outdoor temperature  
 t : Cumulative compressor operating time

- b. Defrost ending conditions

With all models, defrosting stops if the exchanger temperature is above 10 °C or if the defrosting time is over 15 minutes).

### Crankcase heater

When the outdoor exchanger temperature is below -18°C and the heating mode has been stopped for 30 minutes, the compressor windings are powered and maintain the compressor temperature.

When operation has started and the temperature becomes higher than -16°C, heating stops.

## 3.2 Compressor Operating Checks

Using a multimeter set to mega ohm, check that the resistance value across the windings is identical irrespective of the phase (between U and V, V and W, W and U). This value should be approx. 1 Ohm.

Check that resistance between each phase and the earth is infinite. The result should be clear (you should not see the displayed value increasing slowly up to a value greater than the multimeter maximum rating).

## 3.3 Refrigeration Circuit Leak Test

The new regulation requires annual leak testing of installations with a refrigerant charge higher than 2kg.

Leak testing is to be performed with an approved detector that has been appropriately calibrated.

## 3.4 Troubleshooting

**The heat pump is not operating at all (no illuminated indicator):**

- Are the power supply voltage and frequency normal?
- Is the connection to mains correct?
- Have all the connectors been properly inserted?
- Are the fuses on the outdoor unit still operating? *If not, change the bad fuse(s).*
- Is the connection between the outdoor unit and the Hydraulic Unit correct? Do you read 230V AC between terminals 1 and 2 of the Hydraulic Unit terminal block?
- Do you read 230V AC at the transformer primary on the Hydraulic Unit? If not, *change the board.*
- Is there any voltage on the transformer secondary on the Hydraulic Unit? *If not, check the thermal fuse. If the fuse is good, the error comes from the board.*

## 4 Control Settings

---

### 4.1 General

The settings described below are those which can be modified by the user.

We wish to remind you that changing the settings below may cause the heat pump to behave in an undesirable way. A testing period should be conducted before the permanent settings of the heat pump are confirmed. This may require a number of changes to be made by the installer.

There are 4 access levels:

- U: end-user level
- I: commissioning level (installer start-up)
- S: engineer level (specialist)
- C: OEM level (manufacturer) (not available)

## 4.2 Function Table

COMMAND LINE	ACCESS LEVEL	FUNCTION	SETTING RANGE	FACTORY SETTING
<b>Time of day and date</b>				
1	U	Hour/minutes	00:00...23:59	
2	U	Day/month	01.01...31.12	
3	U	Year	1900...2099	
5	S	Start of summertime	01.01...31.12	25.03
6	S	End of summertime	01.01...31.12	25.10
<b>Operator section</b>				
20	U	Language		English
22	S	Info	Temporarily / Permanent	Temporarily
26	S	Operation lock	Off/on	Off
27	S	Programming lock	Off/on	Off
28	S	Direct adjustment...	Auto/confirm	Confirm
29	S	Temperature unit	°C, °F	°C
		Pressure unit	bar, psi	bar
70	S	Software version		
<b>Time prog heating circuit 1</b>				
500	U	Preselection	Mon-Sun   Mon-Fri   Sat - Sun   Mon   Tue   Wed   Thu   Fri   Sat   Sun	Mon-Sun
501	U	1 <sup>st</sup> phase on	00:00...--:--	6:00
502	U	1 <sup>st</sup> phase off	00:00...--:--	22:00
503	U	2 <sup>nd</sup> phase on	00:00...--:--	--:--
504	U	2 <sup>nd</sup> phase off	00:00...--:--	--:--
505	U	3 <sup>rd</sup> phase on	00:00...--:--	--:--
506	U	3 <sup>rd</sup> phase off	00:00...--:--	--:--
515	U	Copy		
516	U	Default values, Circuit 1	No/yes	No
<b>Time prog heating circuit 2</b>				
520	U	Preselection	Mon-Sun   Mon-Fri   Sat - Sun   Mon   Tue   Wed   Thu   Fri   Sat   Sun	Mon-Sun
521	U	1 <sup>st</sup> phase on	00:00...--:--	6:00
522	U	1 <sup>st</sup> phase off	00:00...--:--	22:00
523	U	2 <sup>nd</sup> phase on	00:00...--:--	--:--
524	U	2 <sup>nd</sup> phase off	00:00...--:--	--:--
525	U	3 <sup>rd</sup> phase on	00:00...--:--	--:--
526	U	3 <sup>rd</sup> phase off	00:00...--:--	--:--
535	U	Copy		
536	U	Default values, Circuit 2	No/yes	No
<b>Time program 4 / DHW</b>				
560	U	Preselection	Mon-Sun   Mon-Fri   Sat - Sun   Mon   Tue   Wed   Thu   Fri   Sat   Sun	Mon-Sun
561	U	1 <sup>st</sup> phase on	00:00...--:--	00:00
562	U	1 <sup>st</sup> phase off	00:00...--:--	05:00
563	U	2 <sup>nd</sup> phase on	00:00...--:--	14:30
564	U	2 <sup>nd</sup> phase off	00:00...--:--	17:00
565	U	3 <sup>rd</sup> phase on	00:00...--:--	--:--
566	U	3 <sup>rd</sup> phase off	00:00...--:--	--:--
575	U	Copy		
576	U	Default values	No/yes	No
<b>Time program 5 / Cooling circuit</b>				
600	U	Preselection	Mon-Sun   Mon-Fri   Sat - Sun   Mon   Tue   Wed   Thu   Fri   Sat   Sun	Mon-Sun
601	U	1 <sup>st</sup> phase on	00:00...--:--	8:00
602	U	1 <sup>st</sup> phase off	00:00...--:--	20:00

**Split system (Single phase and 3-phase type)**

COMMAND LINE	ACCESS LEVEL	FUNCTION	SETTING RANGE	FACTORY SETTING
603	U	2 <sup>nd</sup> phase on	00:00...--:--	--:--
604	U	2 <sup>nd</sup> phase off	00:00...--:--	--:--
605	U	3 <sup>rd</sup> phase on	00:00...--:--	--:--
606	U	3 <sup>rd</sup> phase off	00:00...--:--	--:--
615	U	Copy		
616	U	Default values	No/yes	No
<b>Holidays heating circuit 1</b>				
641	U	Preselection	Period 1...8	Period 1
642	U	Period start (Day / Month)	01.01...31.12	
643	U	Period end (Day / Month)	01.01...31.12	
648	U	Operating level	Frost protection   Reduced	Frost protection
<b>Holidays heating circuit 2</b>				
651	U	Preselection	Period 1...8	Period 1
652	U	Period start (Day / Month)	01.01...31.12	
653	U	Period end (Day / Month)	01.01...31.12	
658	U	Operating level	Frost protection   Reduced	Frost protection
<b>Heating circuit 1</b>				
710	U	Comfort setpoint	Reduced temp to 35°C	20°C
712	U	Reduced setpoint		19°C
714	U	Frost protection setpoint	4°C to Reduced temp	8°C
716	S	Comfort setpoint maximum	20°C...35°C	28°C
720	I	Heating curve slope	0,1...4	0,5
721	I	Heating curve displacement	-4,5°C...4,5°C	0°C
726	I	Heating curve adaption	Off, on	Off
730	I	Summer/winter heating limit	8°C...30°C	18°C
732	S	24-hour heating limit	-10°C...10°C	-2°C
740	I	Flow temp setpoint min (for fan convectors)	8°C... 95°C	8°C
741	I	Flow temp setpoint max	8°C... 95°C	55°C
750	S	Room influence	1%...100%	50%
780	S	Quick setback	Off   Down to reduced setpoint   Down to frost prot setpoint	Down to reduced setpoint
790	S	Optimum start control max	0...360min	180 min
791	S	Optimum stop control max	0...360min	60 min
800	S	Reduced setpoint increase start	-30°C...10°C	---
801	S	Reduced setpoint increase end	-30°C...10°C	-5°C
830	S	Mixer valve boost	0...50°C	0
834	S	Actuator running time	30...873s	240s
850	I	Floor curing function	0...5	Off
851	I	Floor curing setpoint manually	0°C...95°C	25°C
856	I	Floor curing day current	0...32	
857	I	Floor curing day completed	0...32	
900	S	Optg mode changeover		Protection mode
<b>Cooling circuit 1</b>				
901	U	Operating mode	Off   Automatic	Automatic
902	U	Comfort setpoint	15...40°C	24°C
907	U	Release	24h/day   Time program HC   Time program 5	24h/day
908	I	Flow temp setp at OT 25°C	6...35°C	20°C
909	I	Flow temp setp at OT 35°C	6...35°C	16°C
912	I	Cooling limit at OT	---/8...35°C	20°C
913	S	Lock time at end of heating	---/8...100h	24h
918	S	Summer comp start at OT	20...50°C	26°C
919	S	Summer comp end at OT	20...50°C	35°C



Split system (Single phase and 3-phase type)

COMMAND LINE	ACCESS LEVEL	FUNCTION	SETTING RANGE	FACTORY SETTING
920	S	Summer comp setp increase	---/1...10°C	4°C
923	S	Flow temp setp min OT 25°C	6...35°C	18°C
924	S	Flow temp setp min OT 35°C	6...35°C	18°C
928	S	Room influence	---/1...100%	80%
932	S	Room temp limitation	---/0...4°C	0.5°C
938	S	Mixing valve decrease	0...20°C	0°C
941	S	Actuator running time	30...650s	120s
945	S	Mixing valve in heating mode	Control   Open	Open
963	S	With prim contr/system pump	No   Yes	No
<b>Heating circuit 2</b>				
1010	U	Comfort setpoint	Reduced temp to 35°C	20°C
1012	U	Reduced setpoint		19°C
1014	U	Frost protection setpoint	4°C to Reduced temp	8°C
1016	S	Comfort setpoint maximum	20...35°C	28°C
1020	I	Heating curve slope	0,1...4	0,5
1021	I	Heating curve displacement	-4,5°C...4,5°C	0°C
1026	S	Heating curve adaption	Off, on	Off
1030	I	Summer/winter heating limit	8°C...30°C	18°C
1032	S	24-hour heating limit	-10°C...10°C	-2°C
1040	S	Flow temp setpoint min (for fan convectors)	8°C... 95°C	8°C
1041	I	Flow temp setpoint max	8°C... 95°C	55°C
1050	I	Room influence	1%...100%	50%
1080	S	Quick setback	Off   Down to reduced setpoint   Down to frost prot setpoint	Down to reduced setpoint
1090	S	Optimum start control max	0...360min	180 min
1091	S	Optimum stop control max	0...360min	60 min
1100	S	Reduced setpoint increase start	-30...10°C	---
1101	S	Reduced setpoint increase end	-30...10°C	-5°C
1130	S	Mixer valve boost	0...50°C	0°C
1134	S	Actuator running time	30...873s	240s
1150	I	Floor curing function		Off
1151	I	Floor curing setpoint manually	0°C...95°C	25°C
1156	I	Floor curing day current	0...32	
1157	I	Floor curing day completed	0...32	0
1200	S	Optg mode changeover		Protection mode
<b>Domestic hot water</b>				
1610	U	Nominal setpoint	Thc...65°C	55°C
1612	U	Reduced setpoint	8°C....Thc	40°C
1620	I	Release of DHW load	24h/day Heating circ time pgms Time program 4/DHW Off-peak rate 4: Time pgm 4/DHW or Off-peak rate Off	Time program 4/DHW
1640	I	Legionella function	Periodically Fixed weekday	Off
1641	I	Legionella function periodically	1 to 7	7
1642	I	Legionella function weekday	Mon,...Sun	Sunday
<b>Swimming pool</b>				
2056	U	Setpoint source heating	8...80	22
<b>Heat pump</b>				
2803	S	Overrun time cond pump	0...240s	240
2843	S	Compressor off time min	0...120min	8min
2844	S	Switch-off temp max	8°C... 100°C	75°C
2862	S	Locking time stage 2	0...40min	5min

**Split system (Single phase and 3-phase type)**

COMMAND LINE	ACCESS LEVEL	FUNCTION	SETTING RANGE	FACTORY SETTING
2873	S	Compressor mod run time	10...240s	240
2882	S	Release integr electric flow	0... 500°Cmin	100°Cmin
2884	S	Release el flow at OT	-30°C...30°C	2°C
2886	S	Compensation heat deficit	Off   On   Only with floor curing fct	Off
2916	S	Max setpoint HP DHW chrg	8°C... 80°C	60°C
2920	S	With electrical utility lock	Lock/release	Released
<b>Supplementary source</b>				
3700	S	Release below outside temp	-50...50°C	2°C
3701	S	Release above outside temp	-50...50°C	
3705	S	Overrun time	0...120min	20min
3720	S	Switching integral	0... 500°Cmin	100°Cmin
3723	S	Locking time	0...120min	30min
<b>DHW storage tank</b>				
5024	S	Switching differential	0...20°C	7°C
5030	S	Charging time limitation	10...600min	90 min
5055	S	Recooling temp	8...95°C	65°C
5057	S	Recooling collector	Off   Summer   Always	Summer
5061	S	Electric immersion heater release	24h/day DHW release Time program 4/DHW	DHW release
5093	S	Not used		
<b>Configuration</b>				
5700	I	Pre-setting	1 to 12	1
5710	I	Heating circuit 1	Off   On	On
5711	I	Cooling circuit 1	Off 4-pipe system 2-pipe system	Off
5715	I	Heating circuit 2	Off   On	On
5731	I	DHW ctrl elem Q3	No charging request   Charging pump   Diverting valve	Diverting valve
5806	I	Type el imm heater flow	1 : 3-stage, 2 : 2-stage excluding, 3 : 2-stage complementary, 4 : Modulating UX	3 : 2-stage complementary
5981	S	Cont type input EX1	NC   NO	NO
5983	S	Cont type input EX2	NC   NO	NC
5985	S	Cont type input EX3	NC   NO	NO
6098	S	Not used	-20...20°C	0°C
6100	S	Readjustm outside sensor	-3...3°C	0°C
6120	S	Frost protection plant	On/off	On
6205	S	Reset to default parameters	No/yes	No
6220	S	Software version	0...99	--
6420	I	Function input H33 Optg mode change HCs+DHW   Optg mode changeover DHW   Optg mode changeover HCs   Optg mode changeover HC1   Optg mode changeover HC2   Optg mode changeover HC3   Error/alarm message   Release swi pool source heat   Release swi pool solar   <b>Dewpoint monitor</b>		
6421	I	Contact type H33	NC   NO	NO
<b>LPB system</b>				
6600	I	Not used	0...16	1
<b>Errors</b>				
6711	U	Reset HP	No/yes	No
6800	S	History 1	Date/time/code	
6802	S	History 2	Date/time/code	
6804	S	History 3	Date/time/code	
6806	S	History 4	Date/time/code	
6808	S	History 5	Date/time/code	
6810	S	History 6	Date/time/code	
6812	S	History 7	Date/time/code	

Split system (Single phase and 3-phase type)

COMMAND LINE	ACCESS LEVEL	FUNCTION	SETTING RANGE	FACTORY SETTING
6814	S	History 8	Date/time/code	
6816	S	History 9	Date/time/code	
6818	S	History 10	Date/time/code	
<b>Service / special operation</b>				
7070	S	HP interval	1..240 months	---
7071	S	HP time since maint	0..240 months	0
7073	S	Cur starts compressor 1/hrs run	0...12	0
7141	U	Emergency operation	On/off	Off
7142	S	Emergency operating function type	Manual/auto	Manual
7150	I	Simulation outside temp	-50...50°C	---
<b>Input / output test</b>				
			No test All OFF Relay output QX1 Relay output QX2 Relay output QX3 Relay output QX4 Relay output QX5 Relay output QX6 Relay output QX31 Relay output QX32 Relay output QX33 Relay output QX34 Relay output QX35 Relay output QX36 Relay output QX21 module 1 Relay output QX22 module 1 Relay output QX23 module 1 Relay output QX21 module 2 Relay output QX22 module 2 Relay output QX23 module 2	
7700	I	Relay test		No test
7710	I	Output test UX1	0...100%	---%
7712	I	PWM-Signal UX1	0...100%	0
7716	I	Output test UX2	0...100%	--
7719	I	PWM-Signal UX2	0...100%	0
7722	I	Cooling mode DO2	On/off	Off
7723	I	Heat pump D3	On/off	Off
7724	I	Output test UX3	0...100%	
7725	I	Voltage value UX3	0...100%	--
7820	I	Sensor temp BX1	-28...350°C	--
7821	I	Sensor temp BX2	-28...350°C	--
7822	I	Sensor temp BX3	-28...350°C	--
7823	I	Sensor temp BX4	-28...350°C	--
7824	I	Sensor temp BX5	-28...350°C	--
7825	I	Sensor temp BX6	-28...350°C	--
7830	I	Sensor temp BX21 module 1	-28...350°C	--
7832	I	Sensor temp BX21 module 2	-28...350°C	--
7849	I	Contact status H2, module 2	Open, Closed	Open
7911	I	Input EX1	0V   230V	--
7912	I	Input EX2	0V   230V	--
7913	I	Input EX3	0V   230V	--
7973	I	Sensor temp BX31	-28...350°C	--
7974	I	Sensor temp BX32	-28...350°C	--
7975	I	Sensor temp BX33	-28...350°C	--
7976	I	Sensor temp BX34	-28...350°C	--
7977	I	Sensor temp BX35	-28...350°C	--
7978	I	Sensor temp BX36	-28...350°C	--
7996	I	Contact state H33	Open   Closed	Open
<b>State of plant</b>				
8000	I	State heating circuit 1		--
8001	I	State heating circuit 2		--
8003	I	State DHW		--
8004	I	State cooling circuit 1		--

Split system (Single phase and 3-phase type)

COMMAND LINE	ACCESS LEVEL	FUNCTION	SETTING RANGE	FACTORY SETTING
8006	I	State heat pump		--
8007	I	Not used		--
8010	I	Not used		--
8011	I	State swimming pool		--
8022	I	State supplementary source		--
<b>Diagnostics heat source</b>				
8402	I	El imm heater flow 1	Off/on	Off
8403	I	El imm heater flow 2	Off/on	Off
8406	I	Condenser pump	Off/on	Off
8410	U	Return temp HP	0...140°C	--
8412	U	Flow temp HP	0...140°C	--
8413	U	Compressor modulation	0...100%	--
8414	I	Modulation electric flow	0...100%	--
8425	I	Temp diff condenser	-50...140°C	--
8454	S	Locking time HP	0...2730h	--
8455	S	Counter number of locks HP	0...65535	--
8456	S	Hours run el flow	0...2730h	--
8457	S	Start counter el flow	0...65535	--
<b>Diagnostics consumers</b>				
8700	U	Outside temperature	-50...50°C	--
8701	U	Outside temp min	-50...50°C	--
8702	U	Outside temp max	-50...50°C	--
8703	I	Outside temp attenuated	-50...50°C	--
8704	I	Outside temp composite	-50...50°C	--
8730	I	Heating circuit pump, circuit 1	Off/on	Off
8731	I	Mixer valve HC1 open	Off/on	Off
8732	I	Mixer valve HC1 closed	Off/on	Off
8740	U	Room temp 1	0...50°C	--
8743	U	Flow temp 1	0...140°C	--
8756	U	Flow temperature cooling 1	0...140°C	--
8760	I	Heating circulation pump, circuit 2	Off/on	Off
8770	U	Room temp 2	0...50°C	20°C
8773	U	Flow temp 2	0...140°C	--
8820	I	DHW pump	Off/on	Off
8821	I	Electric immersion heater DHW	Off/on	Off
8830	U	DHW (domestic hot water) temperature	0...140°C	55°C
8840	S	Hours run DHW pump	0...2730h	--
8841	S	Start counter DHW pump	0...2730h	--
8842	S	Hours run el DHW	0...2730h	--
8843	S	Start counter el DHW	0...65535	--
8900	U	Swimming pool temp	0...140°C	22°C
8950	S	Common flow temp	0...140°C	--
8957	S	Common flow setp refrig	0...140°C	--
9031	I	Relay output QX1	Off/on	On
9032	I	Relay output QX2	Off/on	On
9033	I	Relay output QX3	Off/on	On
9034	I	Relay output QX4	Off/on	Off
9035	I	Relay output QX5	Off/on	Off
9050	I	Relay output QX21 module 1	Off/on	Off
9051	I	Relay output QX22 module 1	Off/on	Off
9052	I	Relay output QX23 module 1	Off/on	Off
9053	I	Relay output QX21 module 2	Off/on	Off
9054	I	Relay output QX22 module 2	Off/on	Off
9055	I	Relay output QX23 module 2	Off/on	Off
9071	U	Relay output QX31	Off/on	On
9072	U	Relay output QX32	Off/on	On

COMMAND LINE	ACCESS LEVEL	FUNCTION	SETTING RANGE	FACTORY SETTING
9073	U	Relay output QX33	Off/on	Off
9074	U	Relay output QX34	Off/on	Off
9075	U	Relay output QX35	Off/on	Off

## 4.3 Adjustment Function Details

### 4.3.1 Date and Time Functions

The controller has an annual clock which contains the time, the day of the week and the date. In order for the function to operate, the time and date must be set properly on the clock.

LINE NO.	PROGRAMMING LINE
1	Hour/minutes
2	Day/month
3	Year
5	Start of summertime
6	End of summertime

**NOTE:** Summer time/winter time change

Dates have been set for changing to summer time or to winter time. The time changes automatically from 2am (winter time) to 3am (summer time) or from 3am (summer time) to 2am (winter time) on the first Sunday following the respective date.

### 4.3.2 User Interface Functions

LINE NO.	PROGRAMMING LINE
20	Language
22	Info
26	Operation lock
27	Programming lock
28	Direct adjustment...
29	Temperature unit Pressure unit

#### Info (22):

- **Temporary:**

After pressing the Info key, the information display returns to the basic "predefined" display after 8 minutes or when pressing the operating mode key.

- **Permanent:**

After pressing the Info key, the information display returns to the "new" standard display after a maximum of 8 minutes. The last selected information value is shown in the new basic display.

#### Operation lock (26):

If the operating lock is activated, the following control elements can no longer be adjusted:

Heating circuit mode, DHW mode, room temp comfort setpoint (knob), occupancy key.

**Programming lock (27):**

If the programming lock is activated, the setting values are displayed but may no longer be changed.

• **Temporary Suspension of Programming**

The programming lock can be temporarily deactivated at programming level. To do this, simultaneously press the OK and ESC keys for at least 3 seconds. The temporary suspension of the programming lock remains in effect until you exit the programming.

• **Permanent Suspension of Programming**

First perform a temporary suspension, then cancel "Programming lock" on line 27.

**Direct adjustment... (28):**

• **Automatic storage**

Correction of the setpoint with the knob is adopted without a particular confirmation (timeout) or by pressing the OK key.

• **Storage with confirmation**

Correction of the setpoint with the knob will be adopted only after pressing the OK key.

**Heating Circuit Assignment**

LINE NO.	PROGRAMMING LINE
70	Software version

**Software version**

The indication shows the current version of the user interface.

**4.3.3 Time Program Functions (heating circuit 1 & 2, DHW, cooling)**

Several control programs are available for the heating circuits and the production of DHW. They are initiated in "Automatic" mode and control the change in temperature levels (and therefore the associated setpoints, reduced and comfort) via the adjusted changeover times.

***Enter changeover times:***

Changeover times can be adjusted in a combined way, i.e., identical times for several days or distinct times for certain days. Preselecting groups of days (e.g., Mon...Fri and Sat...Sun) having the same changeover times makes adjustment of the changeover program considerably shorter.

**Changeover Points**

Line no.				Programming line
HC1	HC2	4/DHW	5	
500	520	560	600	Preselection (Mon-Sun / Mon-Fri / Sat – Sun / Mon...Sun)
501	521	561	601	1 <sup>st</sup> phase On
502	522	562	602	1 <sup>st</sup> phase Off
503	523	563	603	2 <sup>nd</sup> phase On
504	524	564	604	2 <sup>nd</sup> phase Off
505	525	565	605	3 <sup>rd</sup> phase On
506	526	566	606	3 <sup>rd</sup> phase Off

**Standard Program**

Line no.	Programming line
516, 536, 576, 616	Default values (No /Yes)

All time programs can be reset to factory settings. Each time program has its own command line for this reset action.

In this case, individual settings will be lost!

**Holidays:**

Line no. HC1	HC2	Programming line
642	652	Period start (Day / Month)
643	653	Period end (Day / Month)
648	658	Operating level

The holiday program enables changing the heating circuits over to a selected operating level according to the date (calendar).

**Important !**

The holiday program can be used only in the automatic mode.

**4.3.4 Heating Circuit 1 & 2 Functions**

**Operating Mode**

For heating circuits there are several functions available which can be individually adjusted for each heating circuit.

The programming lines for the 2nd heating circuit are displayed only if an extension module has been connected to the controller.

Operation of heating circuits 1 and 2 is directly controlled via the operating mode key.

**Setpoint Values**

Line no. HC1	HC2	Programming line
710	1010	Comfort setpoint
712	1012	Reduced setpoint
714	1014	Frost protection setpoint
716	1016	Comfort setpoint maximum

**Room Temperature:**

Room temperature can be set according to different setpoint values. Depending on the selected mode, these setpoints are activated and provide different temperature levels in the rooms.

The ranges of configurable setpoints are defined by their interdependencies, as shown in the graph below.

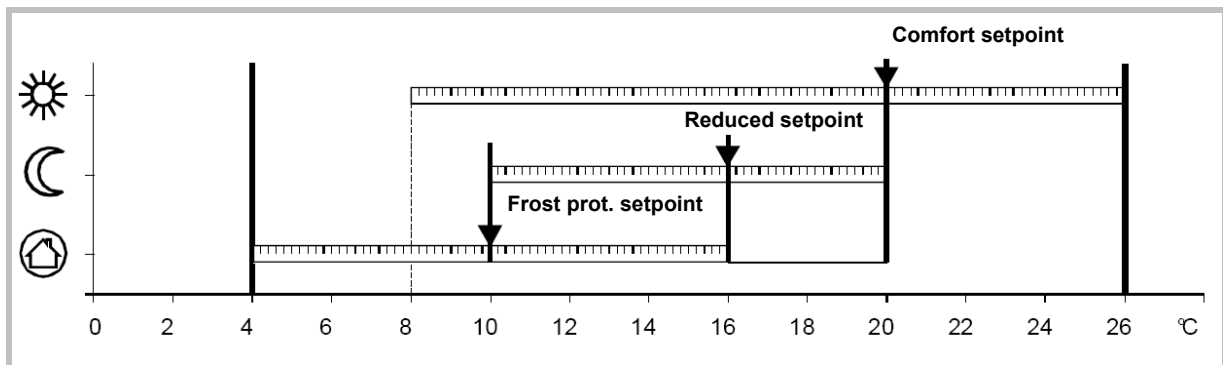

**Frost protection:**

The protection mode automatically prevents an excessively sharp drop in room temperature.

In this case the control adopts the frost protection room setpoint.

## Heating Curve

Line no.	HC1	HC2	Programming line
720	1020		Heating curve slope
721	1021		Heating curve displacement
726	1026		Heating curve adaption

### Heating curve slope:

Based on the heating characteristic, the controller computes the flow temperature setpoint which will be used for controlling the flow temperature in consideration of atmospheric conditions. Different settings can be used to adapt the heating characteristic so that the heating capacity, and therefore the room temperature, will match the individual needs.

The colder the outdoor temperature, the greater the extent to which the slope will modify the flow temperature. In other words, the slope should be corrected if the room temperature shows a difference when the outdoor temperature is low, but not when it is high.

- Increase the setting:  
The flow temperature is increased mainly when the outdoor temperatures are low.
- Decrease the setting:  
The flow temperature is lowered mainly when the outdoor temperatures are low.

### Warning:

The heating curve is adjusted in relation to a room temperature setpoint of 20°C. If the room temperature setpoint is modified, the flow temperature setpoint is automatically recomputed. This will not modify the setting and amounts to automatically adapting the curve.

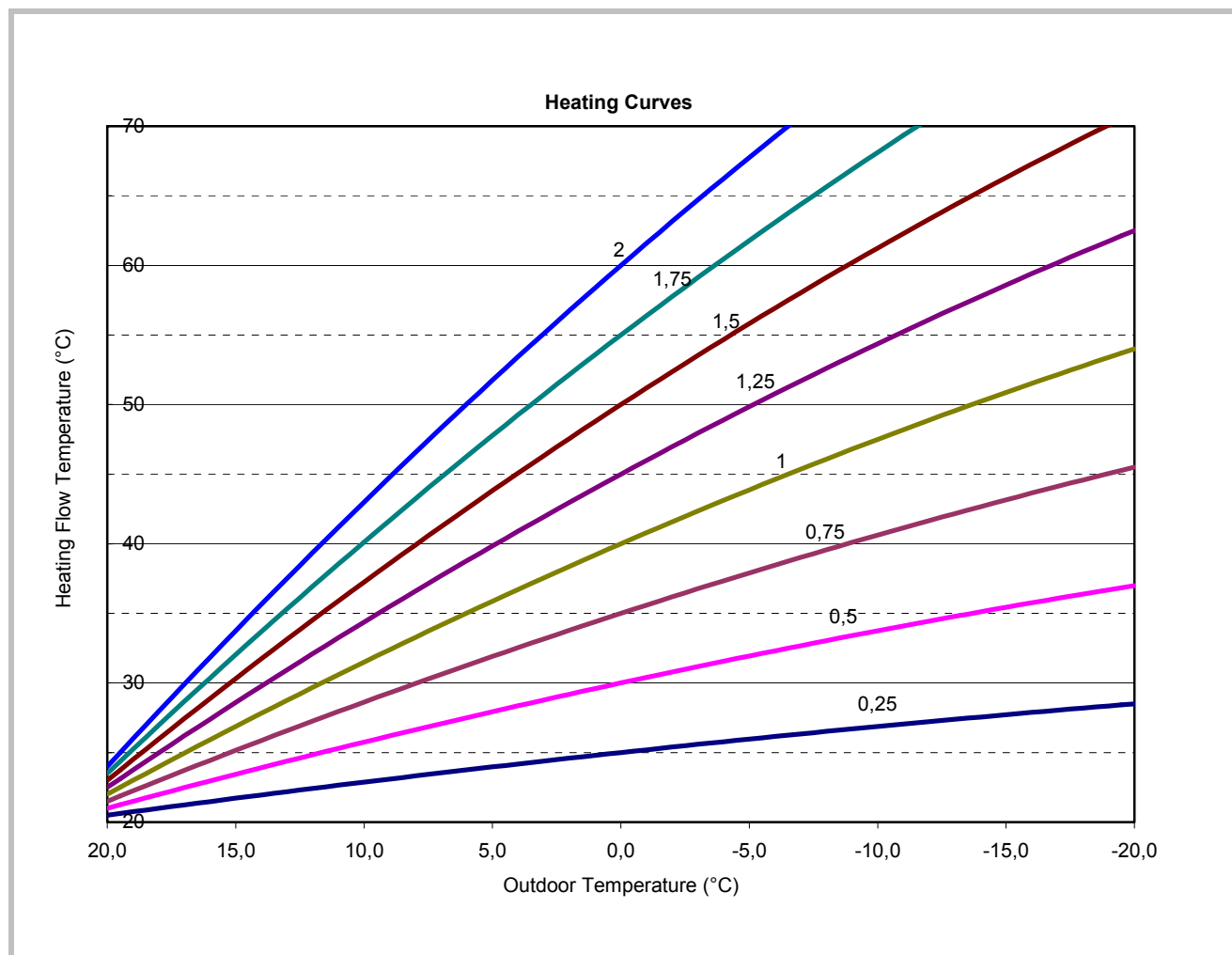



**Heating curve displacement**

The curve shift (offset) modifies the flow temperature in a general and even manner over the full range of outdoor temperature. In other words, the shift should be corrected when the room temperature is generally too high or too low.

**Heating curve adaption**

Adaptation enables the controller to automatically adapt the heating curve to the present conditions. This correction may only be activated or deactivated.

In the latter case, there is no need to correct the slope and shift.

**Information:**

To ensure operation, the following requirements must be met:

- A room sensor must be connected.
- The "room influence" parameter must be set between 1 and 99.
- The reference room (where the room sensor is installed) must not contain adjusted thermostatic valves. If present in the room, these valves must be fully open.
- Operation of this function requires an adaptation period which can take more or less time (approx. 1 week) depending on weather conditions and on the stability of the room temperature setpoint.

**Eco Functions**

Line no.	HC1	HC2	Programming line
730		1030	Summer/winter heating limit
732		1032	24-hour heating limit

**Summer/winter heating limit**

The summer/winter heating limit switches the heating on or off through the year according to the temperature ratio. Changeover is performed automatically when in automatic mode and thus avoids the user having to turn the heating on or off. Changing the input value makes the respective annual periods (summer/winter) shorter or longer.

- If the value is increased:  
Changing to winter operating mode is advanced, changing to summer mode is delayed

- If the value is decreased:  
Changing to winter mode is delayed; changing to summer mode is advanced.

**Information:**

This function does not work in "Continuous Comfort temperature" mode. (Sunlight)  
The controller displays "ECO".  
The outdoor temperature is attenuated to take the building's dynamics into account.

Example:

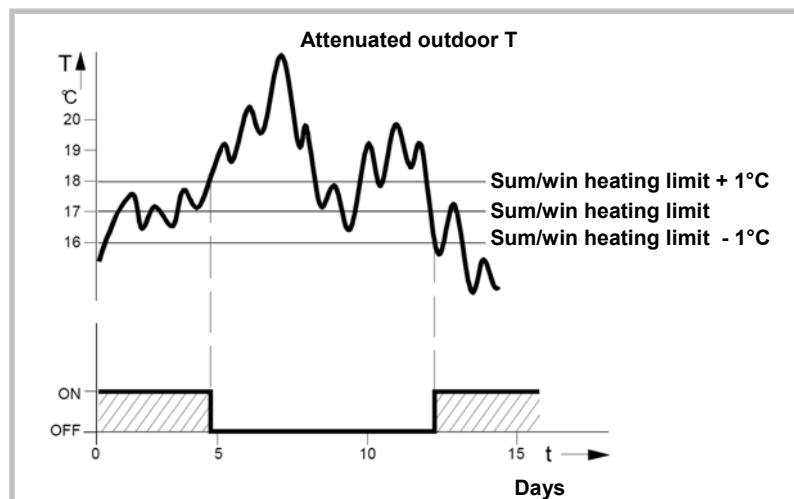

**24-hour heating limit**

The 24-hour heating limit is used to switch the heating on and off in the course of the day, depending on the outside temperature. This function is used mainly during intermediate seasons (spring and fall) to react rapidly in case of fluctuating temperatures.

Thus, in the following example the changeover temperature will be 18°C, computed as follows:

Comfort heating setpoint (710)	22°C
24-Hour heating limit (732)	-3°C
Changeover temperature (710 – 732)	=19°C
Heating off	
Differential (Fixed)	-1°C
Changeover temperature Heating on	=18°C

Changing the input value makes the respective heating periods shorter or longer.

- If the value is increased: changeover to heating mode is advanced; changeover to ECO is delayed.

- If the value is decreased: changeover to heating mode is delayed; changeover to ECO is advanced.

**Information:**

This function will not work in "Continuous Comfort temperature" mode.

The display will show "ECO".

The outdoor temperature is attenuated to take the building's thermal dynamics into account.

**Flow temperature setpoint**

Line no.	HC1	HC2	Programming line
740		1040	Flow temp setpoint min (for fan convectors)
741		1041	Flow temp setpoint max

This limitation allows to define a range for the orders to start. When instructed to start the heating circuit reaches the threshold, this record remains

permanently at the maximum or minimum, even if the heat demand continues to increase or decrease.

**Room Influence**

Line no.	HC1	HC2	Programming line
750		1050	Room influence

**Control types:**

When using a room temperature sensor there are 3 different types of control to choose from.

SETTING	CONTROL TYPE
--- %	Simple control according to outdoor conditions *
1...99 %	Control according to outdoor conditions with room influence *
100 %	Control according to room temperature only

\* Requires the connection of an outdoor sensor

**Simple control according to outdoor conditions**

The flow temperature is computed via the heating curve according to the averaged outdoor temperature.

This type of control requires proper adjustment of the heating curve, as the control does not take the room temperature into account for this adjustment.

**Control according to outdoor conditions with room influence**

The difference between the room temperature and the setpoint value is measured and taken into account for temperature control. This enables taking

into account possible heat inputs and ensures a more even room temperature.

The influence of the difference is defined as a percentage. The better the installation in the reference room (accurate room temperature, correct installation location, etc.) the higher will be the value that can be set.

**Example:**

Approx 60%: the reference room is appropriate

Approx 20 %: the reference room is inappropriate

**Information:**

Activation of the function requires taking into account the following requirements:

## Split system (Single phase and 3-phase type)

- A room sensor must be connected.
- The "room influence" parameter must be set between 1 and 99.
- The reference room (where the room sensor is installed) must not contain adjusted thermostatic valves. If present in the room, these valves must be fully open.

### Control according to room temperature only

The flow temperature is adjusted according to the room temperature setpoint, the current room temperature and its evolution. A slight increase in

room temperature, for example, causes an immediate drop in the flow temperature.

#### **Information:**

Activation of the function requires taking into account the following requirements:

- A room sensor must be connected.
- The "room influence" parameter must be set to 100%.

The reference room (where the room sensor is installed) must not contain adjusted thermostatic valves. If present in the room, these valves must be fully open.

### **Quick setback**

Line no.		Programming line
HC1	HC2	
780	1080	Quick setback

During quick setback, the heating circuit pump is deactivated and, in the case of mixing circuits, the mixing valve is fully closed.

When using a room sensor, the function keeps the heating off until the room temperature drops to the level of the "Reduced" or "Frost protection" setpoint. If the room temperature falls to the reduced or frost level, the heating circuit pump is activated and the mixing valve released.

Quick setback switches the heating off for a certain period of time, depending on the outside temperature and the building time constant.

Duration of quick setback when "Comfort" setpoint minus "Reduced" setpoint = 2 K (e.g. "Comfort" setpoint = 20 °C and "Reduced" setpoint = 18 °C)

	Building time constant [h]
Composite outside temperature	5
	<i>Duration of quick setback [h]</i>
15°C	7.7
10°C	3.3
5°C	2.1
0°C	1.6
-5°C	1.3
-10°C	1.0
-15°C	0.9
-20°C	0.8

### **Optimisation at switch-on and switch-off**

Line no.		Programming line
HC1	HC2	
790	1090	Optimum start control max
791	1091	Optimum stop control max

#### Optimum start control max

The change in temperature levels is optimised in such a way as to reach the comfort setpoint during changeover times.

#### Optimum stop control max

The change in temperature levels is optimised in such a way as to reach the comfort setpoint -1/4 °C during changeover times.

## Reduced Setpoint Increase

Line no.	HC1	HC2	Programming line
800		1100	Reduced setpoint increase start
801		1101	Reduced setpoint increase end

This function is used mainly in heating installations that do not have high supplies of power (e.g. low energy homes). In that case, when outdoor temperatures are low, adjusting the temperature would be too long.

Increasing the reduced setpoint prevents excessive cooling of the rooms in order to shorten the temperature adjustment period when changing over to the comfort setpoint.

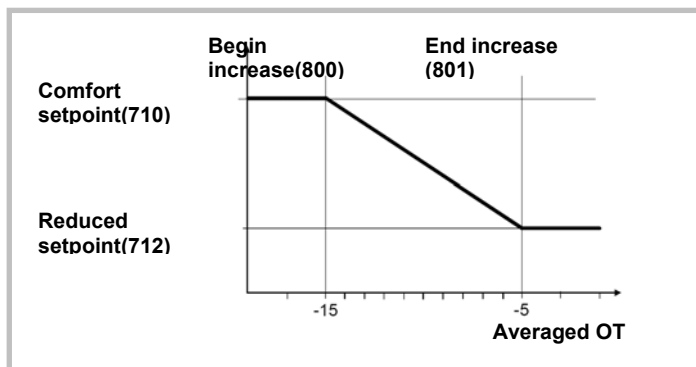

## Mixing Valve Control

Line no.	HC1	HC2	Programming line
830		1130	Mixer valve boost
834		1134	Actuator running time

### Mixer valve boost

The controller adds the increase set here to the current flow setpoint and uses the result as the temperature setpoint for the heat generator.

### Actuator running time

For 3-position control the valve Actuator running time can be adjusted. With a 2-position servomotor, the adjusted travel time is inoperative.

## Controlled floor drying function

Line no.	HC1	HC2	Programming line
850		1150	Floor curing function
851		1151	Floor curing setpoint manually
856		1156	Floor curing day current
857		1157	Floor curing day completed

This function is used in the controlled drying of floors. It adjusts the flow temperature to a temperature profile. Drying is performed by floor heating via the heating circuit with a mixing valve or with a pump.

The second part of the temperature profile is handled automatically..

### Floor curing function

- **Off:**  
The function is deactivated.
- **Heating operational (Fh):**  
The first part of the temperature profile is automatically completed.
- **Heating "ready for occupancy" (Bh)**

- **Heating "ready for occupancy" / Heating operational**  
The full temperature profile (1st and 2nd part) is performed automatically.
- **Manual**  
No temperature profile is performed, but the control is performed according to the "manual controlled drying setpoint". The function is automatically terminated after 25 days

**Important**

- The standards and directions of the building contractor must be followed!
- This function will not work properly unless the installation has been adequately made (hydraulics,

electricity, settings). Otherwise, the floors to be dried may be damaged!

- The function may be prematurely interrupted by setting it to Off.
- The maximum flow temperature limitation remains active.

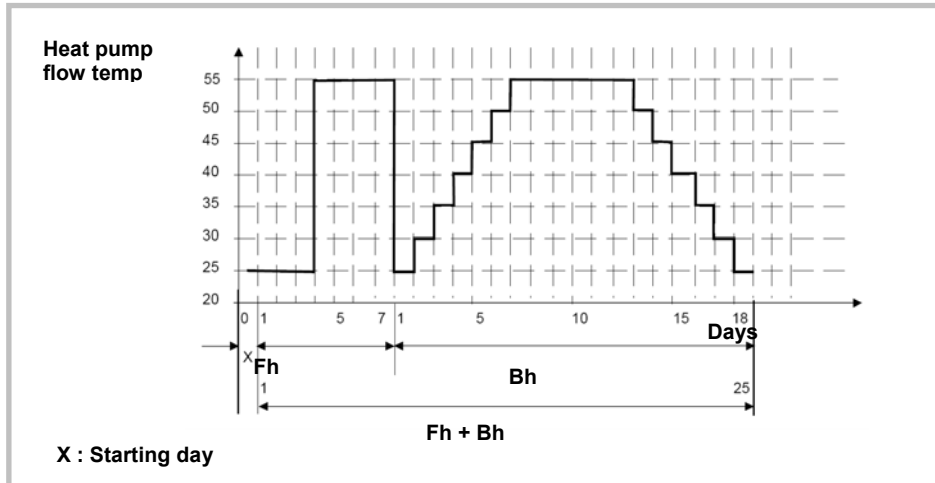

**Floor curing setpoint manually**

The flow temperature setpoint for the "Manual" controlled floor drying function can be adjusted separately for each heating circuit.

**Floor curing day completed**

Displays the current day of the controlled floor drying function

**Floor curing day current**

Displays the current flow temperature setpoint for the controlled floor drying function

**Important:**

After a power outage, the installation resumes the controlled drying function as it was when the outage occurred.

**Operating Mode Changeover**

Line no.	HC1	HC2	Programming line
900		1200	Optg mode changeover (None / Frost protection mode / Reduced / Comfort / Automatic)

In case of an external changeover via input H2 (on the extension module only) the operating mode to which the changeover will be performed must be previously defined.

**Heating Circuit Frost Protection**

The heating circuit frost protection is continuously activated (protection mode ) and is not adjustable.

If the flow temperature rises again above 7°C, the controller waits another 5 minutes, and then stops the production of heat and the heating pumps.

**Heating circuit frost protection in heating mode**

If the flow temperature is below 5°C, the controller initiates the production of heat and starts the heating pumps, regardless of the current heating mode.

**Heating circuit frost protection in cooling mode**

See Cooling mode

### 4.3.5 Cooling Circuit 1 Functions

The cooling sequence is automatically started when the room temperature is higher than the comfort setpoint in cooling mode (line 902). The cooling function must be activated (command line 901 = Auto) and is triggered by the programming clock (Command line 907).

The cooling sequence is interrupted as soon as heating circuit 1 indicates a need for heat or in the presence of a heat demand signal from a DHW circuit or other heating circuit (only if cooling is active).

The controller measures the current room temperature and compares it with the room temperature setpoint to compute the flow temperature setpoint. If the temperature is not low enough the heat pump is started to provide cooling (reversed control of the mixing valve).

#### Operating Mode

Line no.	Programming line
901	Operating mode (Off / Automatic)

The cooling key on the user interface enables switching between operating modes.

- **Off:**

The cooling function is deactivated.

The following settings apply to the hydraulic circuit in zone 1 (HC1).

If there is a second zone, this zone can be cooled with the setting 963 which will connect the pump directly to zone 2. This will require setting the "Mixing valve sub-cooling" parameter (938) to a suitable value in order for both zones to be adequately cooled according to the available emitters.

**WARNING:**

Cooling mode is prohibited on all radiators, heating-only floors, or any emitters not intended for this purpose.

- **Automatic:**

The cooling function is automatically activated by the time program (command line 907), the holiday program, the occupancy key, or according to the need.

#### Comfort cooling setpoint

Line no.	Programming line
902	Comfort cooling setpoint

In cooling mode the room temperature control follows the comfort setpoint adjusted under this setting. The cooling comfort setpoint can be displayed with a knob on the room unit.

In summer the comfort setpoint is gradually increased in relation to the outdoor temperature (see lines 918-920).

#### Release:

Line no.	Programming line
907	Release (24h/day / heating circuit time pgm / Time program 5)

The "Release" setting determines the time program according to which cooling is released.

- **24h/day:**

Cooling is continuously activated (24h/day).

- **heating circuit time program:**

Cooling is activated according to the heating circuit time program.

- **Time program 5:**

Cooling is released according to time program 5.

### Cooling Characteristic

Line no.	Programming line
908	Flow temp setp at OT 25°C
909	Flow temp setp at OT 35°C

The controller computes the flow temperature required for a given averaged outdoor temperature based on the cooling characteristic. This is defined by two reference points (flow setpoint at 25°C and at 35°C).

#### Flow temp setp at OT 35°C

This is the cooling flow temperature required when the averaged outdoor temperature is 35°C, without summer compensation.

#### Flow temp setp at OT 25°C

This is the cooling flow temperature required when the averaged outdoor temperature is 25°C, without summer compensation.

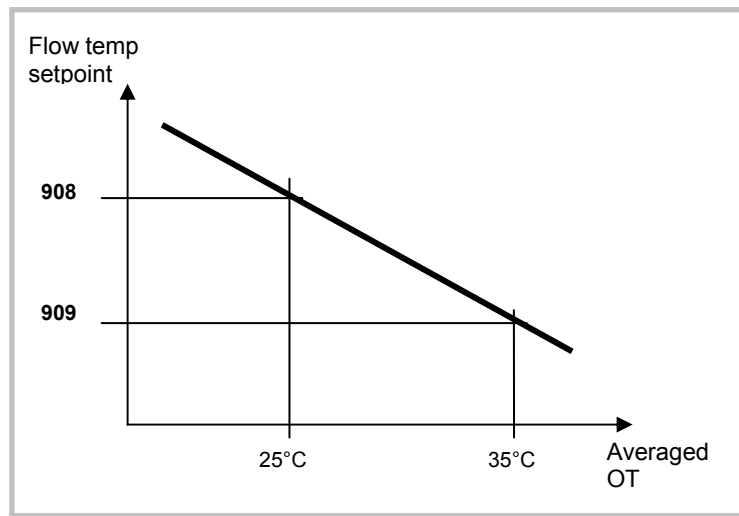

The cooling characteristic is adjusted for a 25°C room temperature setpoint. If the room temperature

setpoint is changed the curve will automatically adapt.

### Eco

Line no.	Programming line
912	Cooling limit at OT
913	Lock time after end of heating

#### Cooling limit at OT

If the composite outdoor temperature is higher than the cooling limit, cooling is released. If the composite outdoor temperature falls at least 0.5°C below the cooling limit, cooling is locked.

#### Lock time after end of heating

To avoid a quick start of cooling after termination of heating, the cooling function is locked for a time period which can be adjusted with this setting. The lock time starts when there is no valid heating demand from heating circuit 1. Heating demands from heating circuits 2 or P are ignored.

#### **Information:**

Switching off and switching on again the mode selection key causes the lock time to be interrupted

### Summer Compensation

Line no.	Programming line
918	Summer comp start at OT
919	Summer comp end at OT
920	Summer comp setp increase

In summer the "cooling comfort setpoint" (902) is gradually increased according to the outdoor temperature. This saves on cooling power and prevents the differences between the ambient temperature of the room and the outdoor temperature being too high.

The resulting "room temperature setpoint" (cooling) can be viewed in the Info section.

#### Summer compensation start at OT

Summer compensation starts to be active from the outdoor temperature defined here. If the outdoor temperature continues to rise, the comfort setpoint will be gradually increased.

#### Summer compensation end at OT

At this outdoor temperature the summer compensation reaches its peak efficiency (920). If the outdoor temperature continues to rise, it will no longer influence the comfort setpoint.

#### Summer compensation setpoint increase

This setting defines the highest value to which the comfort setpoint can be increased.

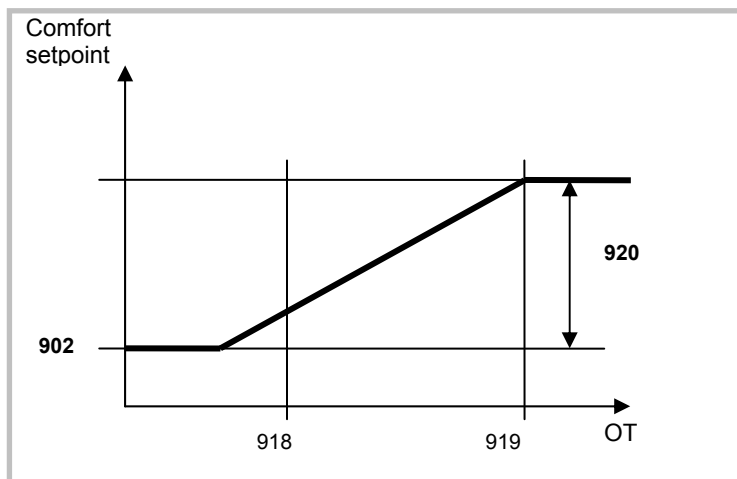



### Flow Setpoint Limitation

Line no.	Programming line
923	Flow temp setp min at OT 25°C
924	Flow temp setp min at OT 35°C

It is possible to assign a lower limit to the cooling flow temperature.  
 The limitation line will be defined by two reference points.  
 In addition the resulting flow setpoint will have a lower limit and may not be less than 5 °C.

#### Flow temp setp min at OT 25°C

Determines the lowest flow temperature for a composite outdoor temperature of 25°C.

#### Flow temp setp min at OT 35°C

Determines the lowest flow temperature for a composite outdoor temperature of 35°C.

#### **Warning:**

If no outdoor temperature is available, the controller will use the "Min. flow setpoint at OT= 35°C" parameter.

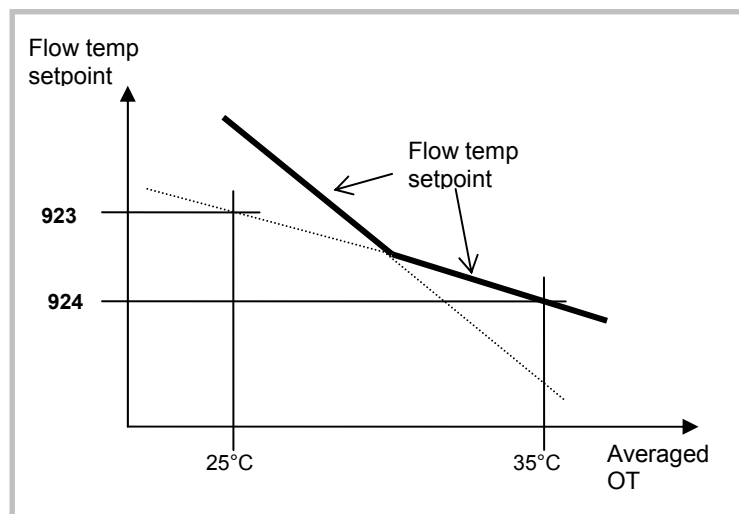

### Room Influence

Line no.	Programming line
928	Room influence

When using a room temperature sensor there are 3 different types of control to choose from.

SETTING	CONTROL TYPE
--- %	Simple control according to outdoor conditions *
1...99 %	Control according to outdoor conditions with room influence *
100 %	Control according to room temperature only

\* Requires the connection of an outdoor sensor

#### Simple control according to outdoor conditions

The flow temperature is obtained from the composite outdoor temperature on the basis of the cooling characteristic.

This type of control requires the cooling curve to be properly adjusted, as the control does not take the room temperature into account for this adjustment.

**Control according to outdoor conditions with room influence**

The difference between the room temperature and the setpoint value is measured and taken into account for temperature control. This enables taking into account possible heat inputs and ensures a more even room temperature. Thus the differences with the room temperature are taken into account and the room temperature becomes more stable. The influence of the difference is defined as a percentage. The better the installation in the reference room (accurate room temperature, correct installation location, etc.) the higher will be the value that can be set.

**Example:**

- Approx 60%: the reference room is appropriate
- Approx 20 %: the reference room is inappropriate

Activation of the function requires taking into account the following requirements:

- A room sensor must imperatively be connected.
- The "room influence" parameter must be set between 1 and 99.
- The reference room (where the room sensor is installed) must not contain adjusted thermostatic valves. Any thermostatic valves present in the rooms must be fully open.

***Room Temperature Limitation***

Line no.	Programming line
932	Room temperature limitation

The "room temperature limitation" function enables shutting off the cooling circuit pump if the room temperature falls below the adjusted room temperature setpoint (with summer compensation line 920) by more than the adjusted differential.

The cooling circuit pump is reinitiated as soon as the room temperature rises again above the current room temperature setpoint.

**Control according to room temperature only**

The flow temperature is adjusted according to the room temperature setpoint, the current room temperature and its evolution. A slight increase in room temperature, for example, causes an immediate drop in the flow temperature.

Activation of the function requires taking into account the following requirements:

- A room sensor must imperatively be connected.
- The "room influence" parameter must be set to 100%.
- The reference room (where the room sensor is installed) must not contain adjusted thermostatic valves. Any thermostatic valves present in the rooms must be fully open.

If the room temperature limitation function is active, no cooling demand will be transmitted to production.

The function is deactivated if:

- no room temperature sensor is available
- "Room influence limit." = ---
- "Room influence" (928) = --- (simple control according to outdoor conditions)

## Mixing Valve Control

Line no.	Programming line
938	Mixing valve cooling offset
941	Actuator running time
945	Mixing valve in heating mode

### Mixing valve cooling offset

The cooling demand issued by cooling circuit 1 to production is reduced by the adjusted value.

If there is a second zone, this reduction should enable the second zone to be cooled. To achieve this result, the sub-cooling must be determined in accordance with the type of emitter and the parameter 963 "With prim control/prim pump" must be set to "yes" to switch on the pump for the second zone.

### Example:

	Configuration	How the configuration affects control
<b>Zone 1:</b> Heating/cooling floor <b>Zone 2:</b> Fan coils	938 = 10°C, with 924 = 18°C 963 = yes	with a 35°C outdoor temperature the flow setpoint will be 18°C – 10°C i.e. 8°C while in the first zone (HCF) it will be 18°C through action of the mixing valve
<b>Zone 1:</b> Heating/cooling floor <b>Zone 2:</b> HCF	938 = 0°C, with 924 = 18°C 963 = yes	with a 35°C outdoor temperature the flow setpoint will be 18°C in both zones

### WARNING:

If these settings are not chosen properly the heat pump may stop automatically due to the flow temperature being too low. A safety mechanism is triggered at 6°C to protect the exchanger from freezing.

This parameter is inoperative in installations where heating and cooling circuits are hydraulically separate.

Control: the valve controls in heating and cooling mode.

Open: the valve controls in cooling mode, and is open in heating mode.

### Actuator running time

For the 3-position servomotor used, it is possible to adjust the travel time. With a 2-position servomotor, the adjusted travel time is inoperative.

### Mixing valve in heating mode

Determines the position of mixing valve 1 (Y1 / Y2) during heating operation is activated.

## With prim controller/system pump

Line no.	Programming line
963	With prim contr/system pump (no / yes)

This setting specifies whether the cooling circuit is supplied from the primary controller or from the primary pump (depending on the installation). It can also be used to provide cooling to the second zone.

### Warning:

In the case of a radiator or any other emitter which does not support the cooling mode in zone 2, this setting must remain on "No".

### 4.3.6 DHW Functions

The control sets the DHW temperature, according to the time program or continuously, to the desired setpoint. The priority of DHW charging over room heating is adjustable in this case.

The controller has a configurable legionella function designed for protection against legionella in the storage tank and the pipes. The circulation pump is controlled according to the current time program and operating mode.

#### Setpoint value

Line no.	Programming line
1610	Nominal setpoint
1612	Reduced setpoint

The DHW is heated to various setpoint values. These setpoints are active according to the selected

operating mode and allow the desired temperatures to be reached in the DHW storage tank.

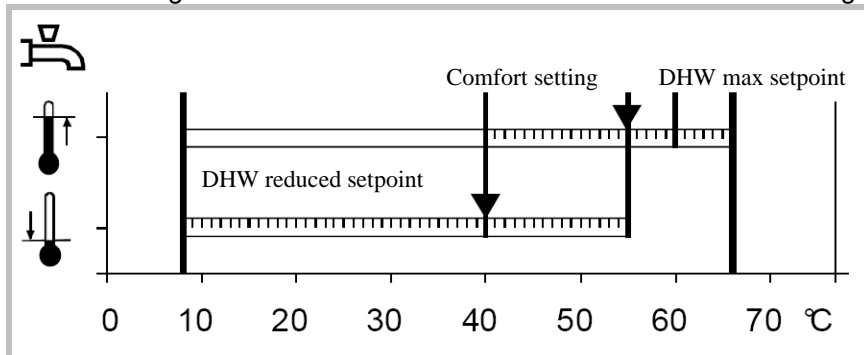

#### Important:

For optimal operation we recommend reducing the setpoints to the lowest value. Setpoints which are too high may interfere with heating and cause some discomfort. In this case DHW/Heating changeover cycles may successively occur.

If DHW charge boosting is not desired during the day, we recommend adjusting the reduced temperature setpoint to 15°C. Full charging will occur during the night at the nominal temperature.

#### Release

Line no.	Programming line
1620	Release of DHW load (24h/day / Heating circ time pgm / Time program 4/DHW / Low-tariff/ Time pgm 4/DHW or Low-tariff)

#### 24h/day

##### (Not recommended)

Regardless of the time programs, the temperature of the domestic hot water is continuously maintained at the DHW nominal setpoint temperature.

##### Example:

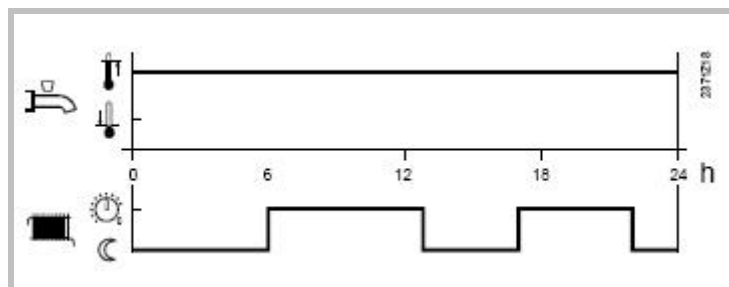

#### Heating circuit time programs:

##### (Not recommended)

## Split system (Single phase and 3-phase type)

Depending on the heating circuit time programs, the DHW setpoint is changed between the DHW temperature nominal setpoint and the DHW temperature reduced setpoint.  
**Example:**

temperature reduced setpoint. The first switch-on point of each phase is advanced by one hour each time.

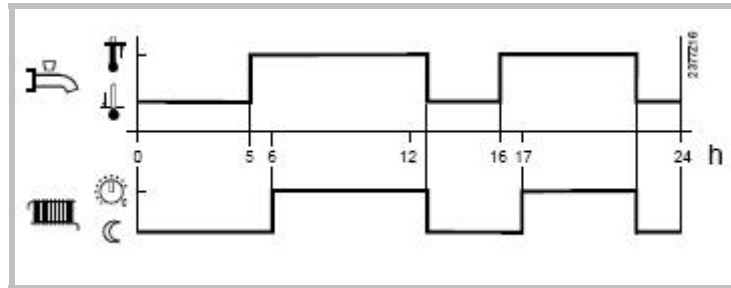

### Time program 4 / DHW:

#### **(Recommended)**

Time program 4 of the local controller is taken into account for the DHW mode. The changeover between DHW nominal setpoint and DHW reduced

setpoint occurs on the changeover times of this program. Thus, domestic hot water charging takes place independently from the heating circuits.

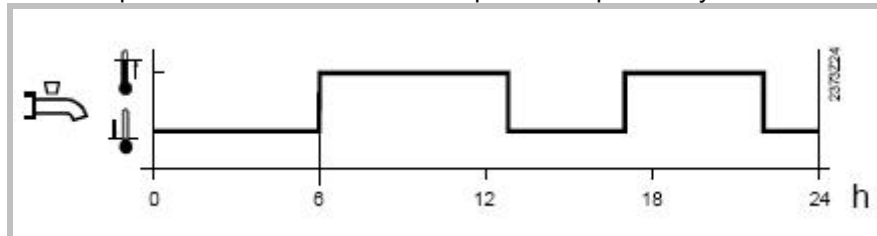

### Low tariff

Released when the low tariff input is active (Input Ex2)

### Time pgm 4/DHW or low tariff

Released when DHW program 4 is set to "Nominal" or if the low tariff input is active.

DHW mode	Holiday status	Release (settings 1620)	Time pgm status (Pgm 4)	Low tariff status (Ex2)	DHW mode level
Off	x	x	x	x	Frost protection
On	Yes	x	x	x	Frost protection
On	No	...	...	x	...
On	No	Low tariff (OPK)	x	Inactive	Reduced
On	No	Low tariff (OPK)	x	Active	Nominal
On	No	Time pgm 4 or OPK	Nominal	Inactive	Nominal
On	No	Time pgm 4 or OPK	Reduced	Inactive	Reduced
On	No	Time pgm 4 or OPK	Nominal	Active	Nominal
On	No	Time pgm 4 or OPK	Reduced	Active	Nominal

x = indifferent

**Information:**

Release by low tariff input always triggers forced DHW charging

If the low tariff input EX2 has not been configured and release via OPK has nevertheless been set, the DHW level will either continuously remain on reduced or will follow time program 4.

**Legionella Function**

Line no.	Programming line
1640	Legionella function
1641	Legionella function periodically
1642	Legionella function weekday

**Legionella function**

- Periodically**

The legionella function occurs repeatedly according to the adjusted periodicity (command line 1641).

- Fixed weekday**

The legionella function can be activated on a fixed day of the week (command line 1642). With this setting, heating up to the legionella setpoint occurs on the scheduled day of the week, regardless of the storage tank temperatures during the previous period.

### 4.3.7 Swimming Pool Functions

Line no.	Programming line
2056	Setpoint source heating

The controller enables a swimming pool to be heated by the heat pump. An individual setpoint can be set by means of parameter 2056, which appears when the swimming pool function is activated by parameter 6046 being set to "Swimming pool release".

Use of input H33 requires an extension to be connected to the control.

### 4.3.8 Heat Pump Functions

Line no.	Programming line
2803	Overrun time cond pump
2843	Compressor off time min
2844	Switch-off temp max
2862	Locking time stage 2
2873	Compressor mod run time
2882	Release integr electric flow
2884	Release el flow at OT
2886	Compensation heat deficit
2916	Max setpoint HP DHW charg
2920	With electrical utility lock

#### Overrun time cond pump

When the compressor is switched off, the condenser pump continues to run for the set overrun time.

#### Compressor off time min

For the same reason, the compressor remains switched off for the minimum period of time set here. Switch-off temperature maximum if the flow or the return temperature exceeds the maximum switch-off temperature, the compressor will be switched off. The heat pump is switched on again when the temperature at both sensors has dropped by the "Switching diff return temp" below the maximum switch-off temperature and the minimum off time has elapsed.

#### Switch-off temp max

If the flow or the return temperature exceeds the maximum switch off temperature, the compressor will be switched off.

#### Locking time stage 2

When compressor is restarted, the time which keeps minimum capacity can be adjusted. Efficiency becomes better; however, the time of rising capacity becomes long.

#### Compressor mod run time

Compressor mod run time means the time of compressor frequency indication changed from minimum to maximum. If this setting value changes to small, compressor frequency changes more quickly.

#### **Warning :**

This setting value is too small, the efficiency is decreased due to the compressor frequency changes frequently.

#### Release integr electric flow

After the release of the 1st stage (heater 1:on, heater 2:off), the controller compares the temperature measured with the point of engagement and forms an integral and includes a possible deficit of heat. Once the value of the integral reaches the maximum value (2882), the 2nd stage is engaged (heater 1:off, heater 2:control). The controller continuously compares the temperature measured at the point of engagement and new features to the deficit of heat in the full release. When the full release reaches the value set (2882), the 3rd stage of the heater is triggered (heater 1:fixed on, heater 2:control).

### Flow elec. release at OT

The heater will be activated only if the attenuated outdoor temperature is below the temperature set here.

#### **Warning:**

If this setting is too low, there may be a feeling of discomfort due to the fact that the heat pump is unable to meet the heating requirements alone at low outdoor temperatures, and heaters are not switched on.

### Compensation heat deficit

This function compensates for excess heat and heat deficits. These can occur in the following situations:

- Minimum compressor on and off times
- In the case of low temperature requests, the flow temperature can lie below the required setpoint, but the return temperature may not drop below the switch-on point for a longer period of time. In this situation, the heat pump must be switched on to prevent heat deficits

The controller compares continuously the flow temperature setpoint with the actual value and integrates the surplus heat and heat deficits. Differences are compensated for by extending the compressor on and off times.

If the compressor is not switched on or off due to surplus heat/heat deficits, the controller displays an appropriate status message.

This function is not active during the time the DHW storage tank is charged.

The function is not active either in the case of plants with buffer/(combi) storage tanks.

"Compensation heat deficit" only acts in heating mode. The parameter is inactive in cooling mode.

The maximum switch-off temperature is given priority over the "Compensation" function.

In the case of sudden setpoint changes, both integrals are cleared.

#### **Behavior in connection with the "Floor curing" function**

When activating the "Floor curing" function, the integral is set to a level representing 1.5 times the predefined value (factory setting). If the current temperature lies at least 2 K below the required setpoint, the heat pump is immediately switched on.

If compensation of surplus heat/heat deficits shall act "Only with floor curing fct", the respective setting

must be selected. This means that the parameter is deactivated in normal heating mode.

#### **Calculation of integral**

- If a flow temperature sensor (BX1) is connected and the heating curve is set to the flow temperature setpoint, the controller uses the flow temperature and the flow temperature setpoint for computing the integrals

In the following situations, the integral is set to "0":

- No valid temperature request delivered
- Setpoint change >2 K
- Frost protection for the heat pump is active
- The heat pump has gone to lockout or cannot deliver any heat for a longer period of time
- The heat pump is in active cooling mode
- A buffer storage tank is being charged
- The function is deactivated

With active DHW charging, the integral value is frozen.

### With electrical utility lock

This setting relates to input Ex1 (load-shedding or peak day clearing) and allows the electric heaters to be locked as follows:

#### **Locked:**

The heat pump and all electric heaters are locked, both heat pump stages and the DHW tank electric auxiliary.

Only the boiler backup, if installed, continues to operate

#### **Released**

The heat pump operates and all electric heaters are locked, both heat pump stages and the DHW tank electric auxiliary.

The boiler backup, if installed, continues to operate.



### 4.3.9 Supplementary source

A supplementary producer can be operated in addition to the main producer (heat pump). Release of the supplementary producer depends on a number of parameters a detailed description of which is given on the following pages.

- Release is effected via release relay QX2
- 2-position control is effected via control relay QX3
- Ux can be used to transmit the supplementary source a DC 0...10 V signal for the required temperature/output setpoint

Line no.	Programming line
3700	Release below outside temperature
3701	Release under outside temperature

Operation of the supplementary source is released only when the composite outside temperature lies above or below the set temperature limit. This enables the supplementary source to lock in a selected outside temperature range to ensure bivalent operation of supplementary source and heat pump.

To ensure continuous release of the supplementary source, setting "---" must be selected on the respective operating lines. If both release values are enabled, the outside temperature must satisfy both criteria, thus ensuring release of the supplementary source .

#### Overtemperature protection

Line no.	Programming line
3705	Overrun time

Overrun time of release for the external source: If the integral indicates another heat deficit before the overrun time has elapsed, the release remains activated.

If the set overrun time elapses before the common flow temperature drops below the common flow temperature setpoint, the release is deactivated also.

#### Flow control

Line no.	Programming line
3720	Switching integral
3723	Locking time

##### Switching integral

The temperature-time integral is a continuous summation of the temperature differential over time. In this case, the decisive criterion is the difference by which the temperature lies above or below the common flow temperature setpoint. The temperature-time integral gives consideration not only to the period of time, but also to the extent of over-/undershoot. This means that when the crossing is significant, the supplementary source is released earlier, or locked earlier, than with minor crossings.

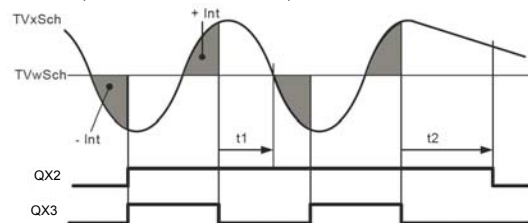

- TVx Actual value of flow temperature
- TVw Flow temperature setpoint
- + Int Surplus integral
- Int Deficit integral
- t1 Overrun time (not completed)
- t2 Overrun time (fully completed)
- QX2 Release output QX2
- QX3 Control QX3

##### Locking time

The locking time enables the heat pump to reach a stable operating state before the supplementary source is allowed to switch on. The supplementary source is released only when the locking time has elapsed. The locking time starts as soon as a valid flow temperature setpoint is available. Calculation of the release integral starts only when the locking time has elapsed.

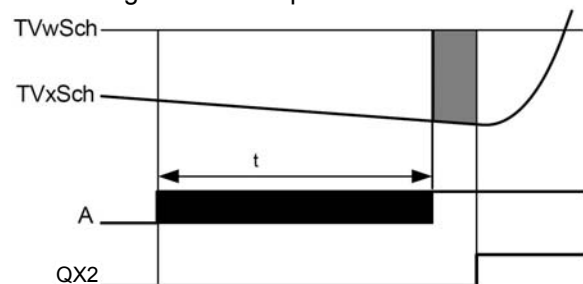

- TVxSch Actual value of common flow temperature
- TVwSch Setpoint of common flow temperature
- A Request
- QX2 Release output QX2
- T Locking time

No consideration is given to the locking time, if the heat pump malfunctions or is locked, or if the

### 4.3.10 DHW Tank Functions

DHW charging at the nominal setpoint temperature (1610) always takes place in two stages. In the first stage, only the heating pump heats the DHW tank. The power supplied during this time is at its peak. Then, when the heat pump is no longer able to supply

supplementary source must end DHW charging. Setting "-" - "-" can be used to deactivate the function.

enough heat to reach the setpoint value, it switches on the DHW tank auxiliary if authorised. The auxiliary will be cut off when charging is complete. While the DHW tank charging process via the electric auxiliary is finishing, the heat pump resumes heating.

### Charging Control

Line no.	Programming line
5024	Switching differential
5030	Charging time limitation

#### Switching differential :

If the DHW temperature is lower than the current setpoint minus the differential set here, the DHW charging process is launched.

It ends when the temperature reaches the current setpoint.

#### **Information:**

Forced charging is triggered on the first DHW release of the day.

Charging is also launched when the DHW temperature is within the differential, and as long as it is not less than 1K above the setpoint.

#### Charging time limitation

During charging, the room heating may be stopped or insufficient. Therefore it is often advisable to limit the charging process timewise to enable heating.

If "-" - "-" has been selected the charging time limitation will be deactivated. The DHW will be heated to the nominal setpoint, even if the room

heating has not received enough power in the meantime.

If a value between 10 and 600 is selected, charging will be suspended after the time period set in minutes, and will remain suspended over that time before resuming. The generator power remains available in the meantime to heat the room. This cycle is repeated until the DHW nominal setpoint has been reached.

#### **Information:**

When the room heating is stopped (summer mode, economy function, etc.), DHW charging remains active, regardless of the setting.

### Recooling

Line no.	Programming line
5055	Recooling temp
5057	Recooling collector

#### Recooling temp :

An activated "Recooling" function remains active until the set recooling temperature in the DHW storage tank is reached.

#### Recooling collector :

When the collector is cold, surplus energy can be emitted to the environment via the collector's surfaces.

## Heater

Line no.	Programming line
5061	Electric immersion heater release

### Electric immersion heater release

- **24h/day**

The heater is continuously active regardless of time programs.

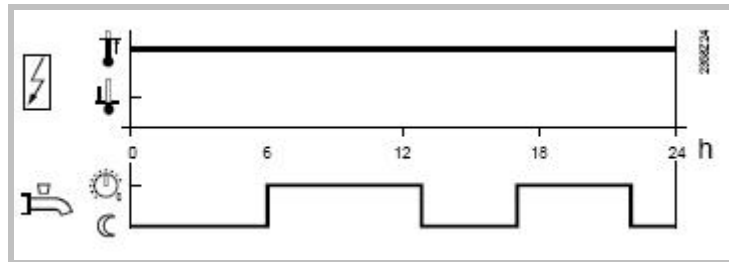

- **DHW release**

The heater is controlled according to "DHW release".

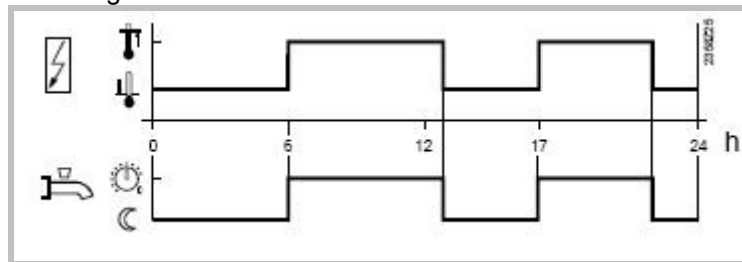

- **Time program 4/DHW**

Time program 4/DHW of the local controller is taken into account for the heater.

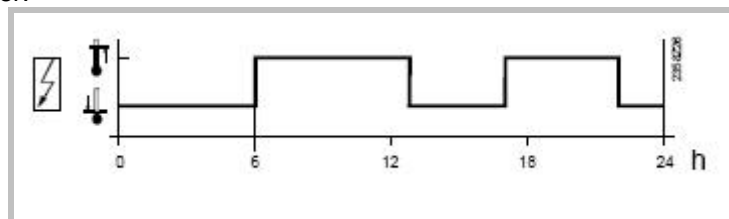

### Information:

Switch-on will actually be in effect only if the heater is able to operate according to the "heater operating mode" setting.

### 4.3.11 Configuration Functions

When an installation is started up, the hydraulic diagram presetting for that installation must be entered.

#### Presettings

Line no.	Programming line
5700	Pre-setting

Only Pre-setting 1 to 4 are used among 9 availables.

#### Heating circuits/Cooling Circuit

Line no.	Programming line
5710	Heating circuit 1
5711	Cooling circuit 1 (Off / 4-pipe system / 2-pipe system)
5715	Heating circuit 2

##### Heating circuit 1

Using this setting, heating circuit 1 can be switched on and off.

##### Cooling circuit 1

**Off:** The cooling circuit is deactivated.

**4-pipe system:** Not compatible with the Waterstage heat pump. This setting relates to passive cooling.

##### 2-pipe system:

Activates the heat pump cooling mode. However, the cooling kit must have been previously connected.

##### Warning:

If the cooling kit has not been connected and the cooling mode is activated the heat pump will behave abnormally and might cause some unwanted discomfort.

##### Information:

Switching on the cooling mode causes the menu "Cooling circuit 1" to appear.

##### Heating circuit 2

Using this setting, heating circuit 2 can be switched on and off.

#### DHW

Line no.	Programming line
5731	DHW ctrl elem Q3

##### No charging request

No DHW charging via Q3.

##### Charging pump

DHW charging is effected with a pump connected to terminal Q3.

##### Diverting valve

DHW charging is effected with a diverting valve connected to terminal Q3.

#### Electric backup

Line no.	Programming line
5806	Type el imm heater flow

Within the type of electric backup, 4 settings are possible :

##### 3-stage

Not used

##### 2-stage excuding

Not used

##### 2-stage complementary

The backup 1 starts alone, then the backup 2 starts alone, then the two backups start simultaneously.  
*Exemple for a 3kw backup and a 6kw backup, 1<sup>st</sup> stage : 3kw, 2<sup>nd</sup> stage : 6kw, 3<sup>rd</sup> stage : 3+6=9kw.*

##### Modulating Ux

The backup 1 is regulated as required.

### Basic unit EX/E

Line no.	Programming line
5981	Cont type input EX1, EX2, EX3
5983	
5985	

The type of contact can be selected:

#### NC

The input's function is active when voltage is **not** present.

#### NO

The input's function is active when voltage is present. The descriptions relating to the functions of the EX contact apply when an NO contact is selected.

### Sensor Corrections

Line no.	Programming line
6098	Not used
6100	Readjustm outside sensor

The outdoor temperature measuring value can be corrected within a range of +/- 3 K.

### Installation Frost Protection

Line no.	Programming line
6120	Frost protection plant

According to the outdoor temperature, the heating circuit pump and the condenser pump are switched on although there is no demand for heat

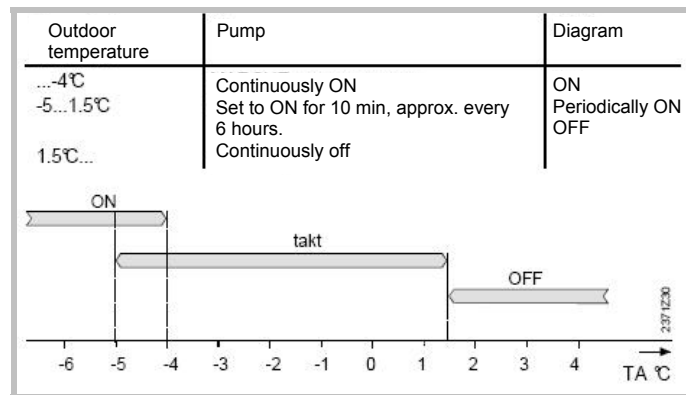

### Miscellaneous

Line no.	Programming line
6205	Reset to default parameters
6220	Software version

#### Reset to default parameters :

All parameters can be reset to factory settings, except when it comes to the following pages: Time and date, User interface and all time programs, as well as the operating hours and the various counters.

#### Software version:

The software version represents the controller software status at the time the unit is being produced. It is printed on the back of the unit.

The first two digits represent the software version, and the third is the revision number (e.g. 01.0)

### 4.3.12 Error Functions

When a fault occurs, the symbol  appears and it is possible to display an error message in the Info section by pressing the Info key.

The display shows what caused the fault.

#### Reset (unlock) Heat Pump

Line no.	Programming line
6711	Reset HP

This line is used to clear the heat pump error messages. The predetermined switch-on delay in case of a failure is therefore ignored, which avoids waiting periods during servicing / troubleshooting.

This option should not be used in normal operating conditions.

#### Fault History

Line no.	Programming line
6800 to 6818	Time stamp and history of faults 1 -10

The controller saves the last 10 faults which have occurred to a non volatile memory. Any new entry will delete the oldest entry from the memory. A fault code and a time are saved for each fault.

#### Error Code List

##### Designation of error

The error designations in the table below are displayed in plain text on the user interface.

##### Location

The sensor or contact associated to the error message.

##### Reset

Reset is either automatic or manual, depending on the type of error (see table below with error messages).

##### Manual reset

Errors which are displayed in the Info section and accompanied by the "Reset?" question can be manually reset.

Press the "OK" key once, "yes" flashes on the display. Press the "OK" key again to confirm the "yes" and the error will be reset.

##### Automatic reset

Automatic clearing occurs after a previously set time (OEM setting) has elapsed. After this timeout (6 hours by default) has elapsed, the controller will attempt to reset the error.

If "Number" appears in the table, it is possible to define how many times the fault can be reset before the heat pump is declared out of order.

#### Heat pump operation

Shows whether or not the heat pump can continue to operate when the error occurs.

##### Yes

The heat pump continues to operate despite the error message.

##### No

The error interrupts operation of the heat pump.

##### No with glycol water

This error stops glycol water heat pumps, but does not prevent operation of water or air heat pumps.

##### No with water

This error stops water heat pumps, but does not prevent operation of glycol water heat pumps

##### No with air

This error stops air heat pumps, but does not prevent operation of water heat pumps or glycol water heat pumps.

##### Per diagram

The heat pump will be stopped according to the current installation diagram.

#### Alarm messages

Errors are ranked by priority. From priority 5 onward (i.e. priority levels 5 - 9) the alarm messages used in remote control (OCI) are sent. In addition, the alarm relay is switched on.

## Split system (Single phase and 3-phase type)

Table of error messages which can be displayed:

No.	Designation of error	Location	Reset		HP oper.
			Manual	Automatic	
0:	No fault				
10:	Outdoor sensor	BX4 (X84)	No	No	Yes
30:	Flow sensor 1	BX1 (X80)	No	No	Yes
31:	Cooling flow sensor 1	BX1 (X80)	No	No	Yes
32:	Flow sensor 2	BX31 (X153)	No	No	Yes
33:	Heat pump flow temp sensor error	BX1 (X80)	No	No	Yes
44:	Heat pump return temp sensor error	BX2 (X80)	No	No	per diagram
50:	DHW temp sensor 1	BX3 (X84)	No	No	Yes
60:	Room sensor 1		No	No	Yes
65:	Room sensor 2		No	No	Yes
76:	Special sensor 1	Bx	No	No	Yes
83:	BSB wire short-circuit		No	No	Yes
84:	BSB, address collision		No	No	Yes
85:	Radio communication error		No	No	Yes
98:	Extension module 1		No	No	Yes
99:	Extension module 2		No	No	Yes
100:	2 master clocks on bus		No	No	Yes
102:	Clock without running supply		No	No	Yes
105:	Maintenance message		No	No	Yes
121:	HC1 flow temp too low		No	No	Yes
122:	HC2 flow temp too low		No	No	Yes
126:	DHW charge monitoring		No	No	Yes
127:	Anti-legionella temperature		No	No	Yes
134:	Heat pump alarm summary	E20	Yes	Number *	No
138:	No heat pump control sensor		No	Yes	No
146:	Sensor / control device configuration		No	No	Yes
171:	Alarm contact 1 activated	H1/H31	No	No	Yes
172:	Alarm contact 2 activated	H21/H22/H32	No	No	Yes
174:	Alarm contact 4 active H3		No	No	Yes
178:	HC1 safety thermostat		No	No	Yes
179:	HC2 safety thermostat		No	No	Yes
201:	Frost alarm	BX1 (X80)	Yes	No	No
243:	Swimming pool sensor	BX34 (X154)	No	No	Yes
325:	BX/ext unit: same sensors		No	No	Yes
327:	Ext modules: same functions		No	No	Yes
329:	Ext modules/mixing grp: same functions		No	No	Yes
330:	BX1 no function		No	No	Yes
331:	BX2 no function		No	No	Yes
332:	BX3 no function		No	No	Yes
333:	BX4 no function		No	No	Yes
334:	BX5 no function		No	No	Yes
335:	BX21 no function		No	No	Yes
336:	BX22 no function		No	No	Yes
357:	cooling circuit flow temp not reached		No	No	Yes
359:	no cooling valve Y21		No	No	Yes
360:	no process reversing valve Y22		No	No	Yes
364:	Heat pump cooling system error		No	No	Yes
369:	External fault				No
370:	Outdoor unit fault				No

Number\* If such statuses or events occur for the first time, they will not directly generate a fault message, but only a status message.

Only if the anomaly occurs repeatedly over a predefined time period and at a given frequency (number) will an error message be generated.

### 4.3.13 Maintenance / Special Operating Mode Functions

#### Maintenance

Maintenance functions can be used as a preventive step for periodically monitoring the installation. All maintenance functions can be individually activated / deactivated.

The controller automatically generates maintenance messages if the settings defined are either exceeded or fail to be reached.

Line no.	Programming line
7070	HP interval
7071	HP time since maint
7073	Cur starts compressor 1/hrs run

#### HP interval :

Defines the maintenance frequency (in months) for the heat pump.

#### HP time since maint :

Displays the time (months) elapsed since the last maintenance. If the value exceeds the "heat pump interval" setting (Line 7070), the symbol  will be displayed and a maintenance message will appear in the Info section:

*17: Heat pump maintenance Interval (Priority 6)*

This setting can be reset with the associated rights of access.

#### Cur starts compressor 1/hrs run :

The average number of compressor startups per hour of operation, obtained over a period of 6 weeks. If the value exceeds the "Comp1 max startups/hr op" adjusted setting, the symbol  will be displayed and a maintenance message will appear in the Info section:

*8: Too many compressor 1 startups (Priority 9)*

This setting can be reset with the associated rights of access.

#### Emergency mode

If the heat pump is not operating properly, a emergency service can be maintained. The emergency mode enables the installation to be run

with the available heaters (flow, storage tank, DHW tank). In this case the compressor will remain off.

Line no.	Programming line
7141	Emergency operation
7142	Emergency operating function type

#### Emergency operation (7141):

Emergency operation can be activated and deactivated manually.

- **Off:**  
Emergency operation is deactivated.
- **On:**  
Emergency operation is activated.

#### Emergency operating function type (7142):

- **Manual:**  
Emergency operation can be activated/deactivated only through the Emergency operation setting on line 7141.

- **Automatic:**  
As soon as a fault occurs on the heat pump, emergency operation is automatically switched on. It stops when the fault is removed and, if necessary, cleared (reset). Emergency mode may however be activated / deactivated manually via the "Emergency operation" setting on line 7141.



## Simulation

Line no.	Programming line
7150	Simulation outside temp

### Simulation outside temp (7150):

To make the starting-up and troubleshooting processes easier, it is possible to simulate an outdoor temperature in the range of -50...+50°C. During simulation, the current, composite and attenuated outdoor temperatures are ignored and substituted with the adjusted simulation temperature.

Computation of the three outdoor temperatures based on the actual outdoor temperature continues to be performed during the simulation, and these temperatures are available again when the simulation is over.

This function can be deactivated by selecting -- on this line or automatically, after a 5 hour waiting period.

### 4.3.14 Input / Output Testing Functions

Input/output testing is used to ensure that the connected components are in working order.

#### Relay Output Testing

Selection of a setting from relay testing closes the corresponding relay and therefore switches on the connected component. This makes it possible to

check that the relays are in working order and that the wiring has been performed correctly.

Line no.	Programming line
7700	<p>Relay test</p> <p>This consists of instructing the regulator's relays one by one and checking their outputs. This enables you to check that the relays are working and that the cabling is correct. Check that each appliance in the installation is operating correctly.</p> <p>(0) No test, (1) Everything is on STOP, (2) Relay output QX1 : heat pump CC1 (Main regulation board), (3) Relay output QX2 : Electrical back-up (1st stage) or Boiler connection distribution valve, (4) Relay output QX3 : Electrical back-up (2nd stage) or Boiler connection contact, (5) Relay output QX4 : DHW distribution valve, (6) Relay output QX5 : DHW Electrical back-up, (7) Relay output QX6 , (8) Relay output QX31 : Heat circ mix valve open Y1, (9) Relay output QX32 : Heat circ mix valve close Y2, (10) Relay output QX33 : heat pump CC2, (11) Relay output QX34, (12) Relay output QX35 : Swimming pool distribution valve, (13) Relay output QX21 module 1, (14) Relay output QX22 module 1, (15) Relay output QX23 module 1, (16) Relay output QX21 module 2, (17) Relay output QX22 module 2, (18) Relay output QX23 module 2, (19) Not used, (20) Not used, (21) Not used.</p> <p>The display shows the "Key" symbol. Pressing the Info button displays "Error 368".</p> <p><b>Warning: The component being tested is receiving electrical power throughout the test.</b></p>

#### Warning:

During testing of an output, the heat pump is stopped, all outputs are "off" and only the controlled output is on.

#### Analog Input/Output Testing

Line no.	Programming line
7710	Output test UX1
7712	PWM signal UX1
7722	Cooling mode DO2
7723	Heat pump D3
7724	Output test UX3
7725	Voltage value UX3

#### Output test UXx

Enables testing the outdoor unit control.

#### Cooling mode DOx

Shows the output status.

#### Sensor Input Testing

Line no.	Programming line
7820	Sensor temp BX1
7821	Sensor temp BX2
7822	Sensor temp BX3
7823	Sensor temp BX4

Displays the temperature of each sensor.

### Input test EX1-3

Line no.	Programming line
7911	Input EX1
7912	Input EX2
7913	Input EX3

By selecting a setting from input test EX1-3, the relevant input will be displayed, enabling it to be checked.

Display of 0 V means that there is no voltage and the respective input is currently inactive. Display of 230 V means that voltage is present at the respective input so that it is activated.

### Input / output test I/O module

Line no.	Programming line
7973	Sensor temp BX31
7976	Sensor temp BX34
7996	Contact state H33

The sensor test operate the same as for BX1-4 on the basic unit

## 4.3.15 Status Functions

The current operating status of the installation can be viewed by means of status displays.

### Messages

Line no.	Programming line
8000	State heating circuit 1
8001	State heating circuit 2
8003	State DHW
8004	State cooling circuit 1
8006	State heat pump
8007	Not used
8010	Not used
8011	State swimming pool
8022	State supplementary source

**State heating circuit**

<b>End user (Info level)</b>	<b>Startup, heating engineer</b>
Thermostat response	Thermostat response
Manual action active	Manual action active
Controlled drying active	Controlled drying active
Heating mode restriction	Overheating protection active Restriction, Boiler protection Restriction, DHW priority Restriction, storage tank
Forced draft	Forced draft, storage tank Forced draft, DHW Forced draft generator Forced draft Switch-off delay active
Comfort heating mode	Optimis. at switch-on + accelerated heating Optimisation at switch-on Accelerated heating Comfort heating mode
Reduced heating mode	Optimisation at switch-off Reduced heating mode
Frost protection active	Room frost protection Flow frost protection active Install. frost protection active
Summer mode	Summer mode
Off	Eco day active Reduced decrease Frost protection decrease Room temperature limitation Off

**State DHW (8003):**

<b>End user (Info level)</b>	<b>Startup, heating engineer</b>
Thermostat response	Thermostat response
Manual action active	Manual action active
Draw-off mode	Draw-off mode
Adiabatic cooling active	Adiabatic cooling by collector adiabatic cooling via gen/HC
Charging lock active	Discharge protection active Charging duration limit. active Charging locked
Forced charging active	Forcing, DHW tank max temp Forcing, max charging temp Forcing, anti-legion. setpoint Forcing, comfort setpoint
Charging by heater	Charging by heater, anti-legion. setpoint Charging by heater, Comfort setpoint Charging by heater, Reduced setpoint Charging by heater, frost protection setpoint Heater released
Accelerated charging active	Flow active Anti-legion. accelerated charging
Charging active	Charging, anti-legion. setpoint Charging, Comfort setpoint Charging, Reduced setpoint
Frost protection active	Frost protection active
Switch-off delay active	Switch-off delay active
Charging on standby	Charging on standby
Charged	Charged, max tank temp Charged, max charging temp Charged, anti-legionella temp Charged, comfort temp Charged, reduced temp
Off	Off
Ready	Ready

**State cooling circuit (8004):**

<b>End user (Info level)</b>	<b>Startup, heating engineer</b>
Dewpoint sensor activated	Dewpoint sensor activated
Manual action active	Manual action active
Fault	Fault
Frost protection active	Flow frost protection active
Cooling mode locked	Locked, heating mode Lock time after heating Locked, generator Locked, storage tank
Cooling mode restricted	Flow temp setpoint increase by hygrostat Dewpoint flow min limit Outdoor temp flow min limit
Comfort cooling mode	Comfort cooling mode Switch-off delay active
Cooling protection mode	Cooling protection mode
Frost protection active	Frost protection active
OT cooling limit activated	OT cooling limit activated
Off	Off Room temperature limitation Flow limit reached
Cooling mode off	Cooling mode off

**State heat pump (8006):**

<b>End user (Info level)</b>	<b>Startup, heating engineer</b>
Emergency mode	Emergency mode
Fault	Fault
Locked	Locked, outdoor temperature Locked, external Locked, economy mode
Lim. time active	Consumer flow rate controller Min outdoor temp use limit Max outdoor temp use limit Max switchoff temp lim Max OT limit cooling Min switchoff temp limit Comp min switchoff time active Excess heat compensation
Frost protection active	Heat pump frost protection
Defrosting activated	Defrosting activated
Cooling mode active	Comp min ON time active Comp 1 ON
Heating	Comp min ON time active Heat deficiency compensation Max cond diff limit Min cond diff limit Comp.1 and heater ON Comp 1 ON Heater ON
Frost protection active	Install. frost protection active
Off	Flow active Switch-off delay active No demand

**State swimming pool (8011):**

<b>End user (Info level)</b>	<b>Startup, heating engineer</b>
Manual action active	Manual action active
Fault	Fault
Heating mode restriction	Heating mode restriction
Forced draft	Forced draft
Heating	Generator heating mode
Heated, max pool temp	Heated, max pool temp Heated, generator setpoint
Heated	Solar heating mode OFF
Heating off	Generator heating mode OFF
Cooling	Cooling

**State supplementary source (8022):**

End user (Info level)	Startup, heating engineer
Locked	Locked, solid fuel boiler Locked, outside temperature Locked, economy mode
In operation for HC, DHW	In operation for HC, DHW
Released for HC, DHW	Released for HC, DHW
In operation for DHW	In operation for DHW
Released for DHW	Released for DHW
In operation for heating circuit	In operation for heating circuit
In operation for HC, DHW	In operation for HC, DHW
Released for HC, DHW	Released for HC, DHW
In operation for DHW	In operation for DHW
Released for DHW	Released for DHW
In operation for heating circuit	In operation for heating circuit
Released for HC	Released for HC
Overrun active	Overrun active
Off.	Off.

### 4.3.16 Generator Diagnosis Functions

Various setpoints and actual values, relay switch status data can be displayed for purposes of diagnosis.

**Heat Pump:**

Line no.	Programming line
8402	El imm heater flow 1
8403	El imm heater flow 2
8406	Condenser pump

These command lines are used to check the operating mode of the components controlled by the heat pump relays. The display "0" means that the associated components are currently disconnected. The display "1" means that the associated components are currently switched on.

**Information**

This information applies to relays defined as normally open contacts. For normally closed contacts, the action is reversed.



### Setpoints and Measured Values

Line no.	Programming line
8410	Return temp HP
8412	Flow temp HP
8413	Compressor modulation
8414	Modulation electric flow
8425	Temp diff condenser

These lines allow the various setpoints and measured values for the heat pump to be viewed.

### Hour / Startup Counter

Line no.	Programming line
8454	Locking time HP
8455	Counter number of locks HP
8456	Hours run el flow
8457	Start counter el flow

#### Locking time HP

Displays the cumulative locking time since start-up by the electrical services (via external locking signal).

#### Hours run el flow, Start counter el flow

These lines are used to view the hours of operation and the number of startups of electric heater.

#### Counter number of locks HP

Displays the cumulative locks since start-up by the electrical services (via external locking signal).

## 4.3.17 Consumer Diagnosis Functions

Various setpoints and actual values, relay switch status and timing status data can be displayed for purposes of diagnosis.

### Outdoor Temperatures

Line no.	Programming line
8700	Outside temperature
8701	Outside temp min
8702	Outside temp max
8703	Outside temp attenuated
8704	Outside temp composite

The current, minimum, maximum, attenuated and composite outdoor temperatures are displayed.

### Heating Circuits

Line no.	Programming line
8730 and 8760	Heating circuit pump, circuit 1
8731 and 8761	Mixer valve HC1 open
8732 and 8762	Mixer valve HC1 closed
8740 and 8770	Room temp
8743 and 8773	Flow temp

The display "Off" means that the associated components are currently disconnected. The display

"On" means that the associated components are currently switched on.

### Cooling Circuit

Line no.	Programming line
8756	Flow temperature cooling 1
8757	Flow temperature setpoint cooling 1

The actual values of the cooling mode are displayed.

The cooling mode room setpoint is displayed on programming line 8741.

### Domestic Hot Water

Line no.	Programming line
8820	DHW pump
8821	Electric immersion heater DHW
8830	DHW (domestic hot water) temperature
8840	Hours run DHW pump
8841	Start counter DHW pump
8842	Hours run el DHW
8843	Start counter el DHW

The measured values, the DHW circulation pump and charging temperature, operating hour and startup

counters are displayed, as well as temperatures of the primary controllers and DHW heater.

### Swimming Pool

Line no.	Programming line
8900	Swimming pool temp

The current and setpoint temperature of the swimming pool are displayed.

### Line

Line no.	Programming line
8950	Common flow temp

### Multifunction Relay Status

Line no.	Programming line
9031	Relay output QX1
9032	Relay output QX2
9033	Relay output QX3
9034	Relay output QX4
9035	Relay output QX5

The switching status of multifunction relays 1 - 5 can be viewed individually on these lines. The display "Off" means that the components assigned to this

output are currently disconnected. The display "On" means that the associated components are currently switched on.

### Status of Relays for Extension Modules 1 and 2

Line no.	Programming line
9050	Relay output QX21 module 1
9051	Relay output QX22 module 1
9052	Relay output QX23 module 1
9053	Relay output QX21 module 2
9054	Relay output QX22 module 2
9055	Relay output QX23 module 2

The switching status of the relays connected to extension modules 1 and 2 can be viewed on these programming lines.

The display "Off" means that the components assigned to this output are currently disconnected. The display "On" means that the associated components are currently switched on.

### I/O module

Line no.	Programming line
9071	Relay output QX31
9072	Relay output QX32
9073	Relay output QX33
9074	Relay output QX34
9075	Relay output QX35

The switching states of each relay on the I/O module can be queried via these operating lines.

- The display of "Off" means that the plant component assigned to the output is currently off
- The display of "On" means that the relevant plant component is currently on

## 5 Annual Maintenance Services

---

### 5.1 Hydraulic Circuit

- clean filter (if any)
- inspect heating system (system pressure, purging, leak test)
- inspect expansion vessel (preload with nitrogen at 1 bar)
- fix any leaks

### 5.2 Outdoor unit

- clean heat exchanger
- clean refrigeration and ventilation compartment
- check for correct condensation drain
- conduct refrigeration circuit leak test (required if charged > 2 kg)

### 5.3 Electrical

- Inspect connections and tighten where appropriate
- Check condition of wires and boards

### 5.4 Operating checks

- conduct refrigeration readings at temperatures
- in case of malfunction, install pressure gauges for refrigeration diagnosis
- check voltage, current and control

## 6 Disassembly Process of Outdoor Unit

### > Warning ! <

Before servicing the unit, turn the power supply switch OFF, then, do not touch electric parts for 10 minutes due to the risk of electric shock.

### 6.1 Single phase type

#### 6.1.1 Appearance

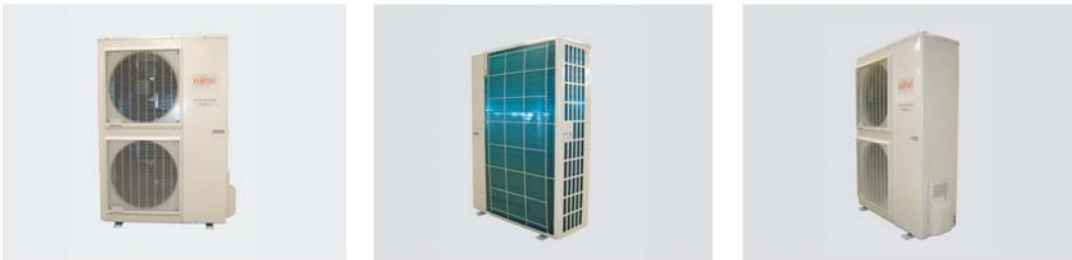

#### 6.1.2 Service panel removal

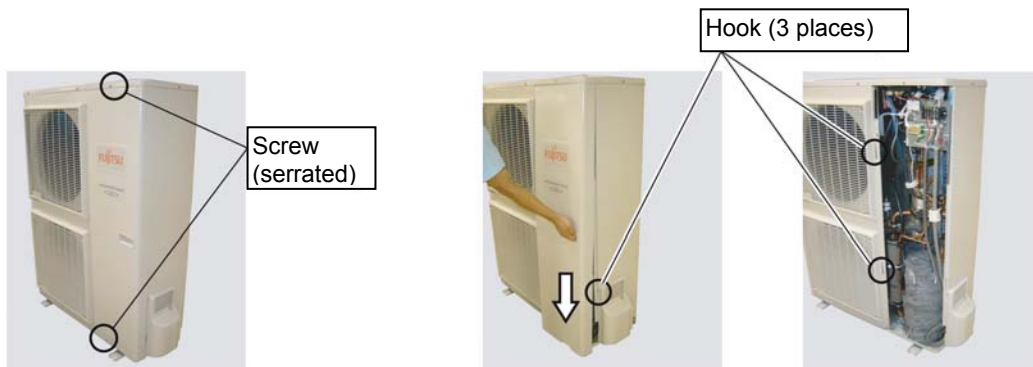

Remove the mounting screws.

Remove the SERVICE PANEL by sliding downward.

#### 6.1.3 Top panel removal

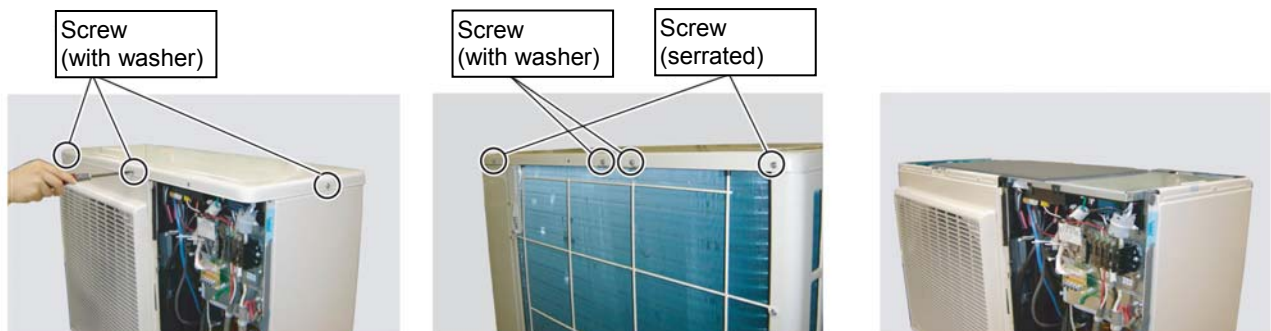

Remove the mounting screws

Remove the TOP PANEL

### 6.1.4 MAIN PCB, FILTER PCB, and INDICATOR PCB removal

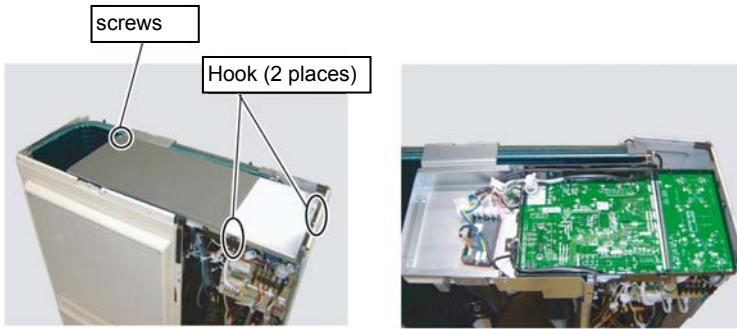

Remove the 1 mounting screw

Remove the INVERTER BOX COVER by sliding upward.

Single Phase type

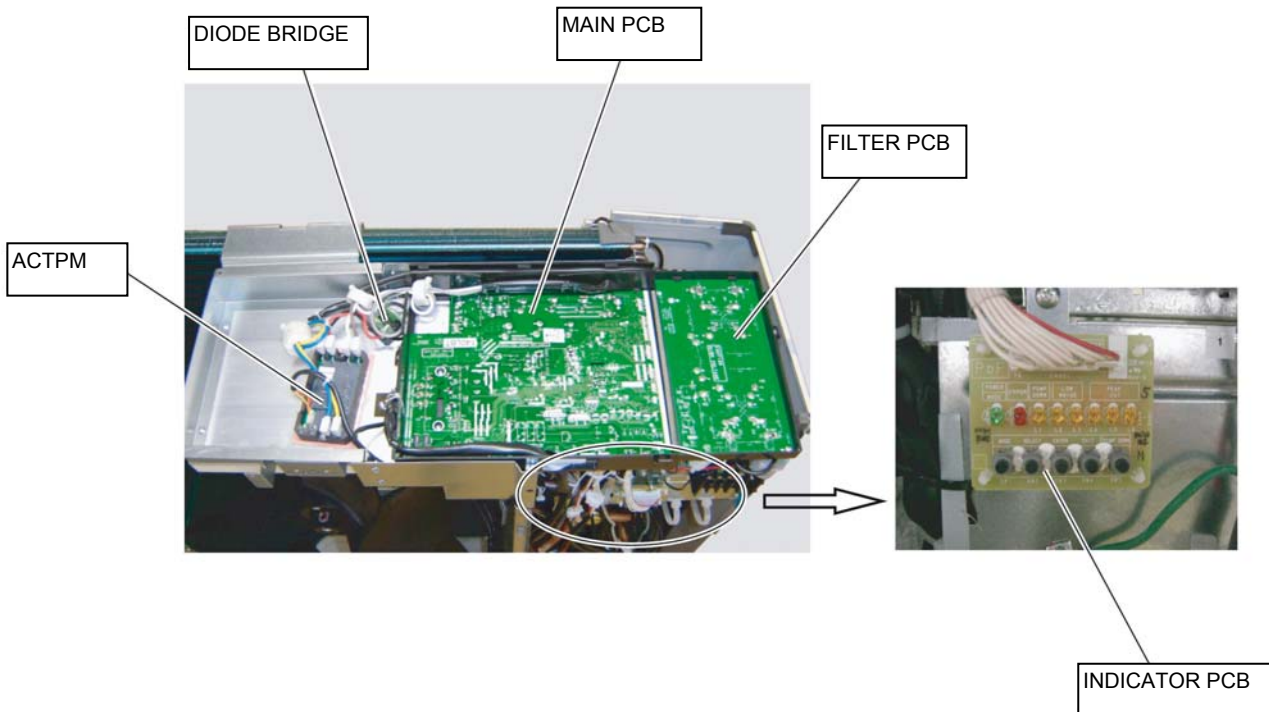

### MAIN PCB removal

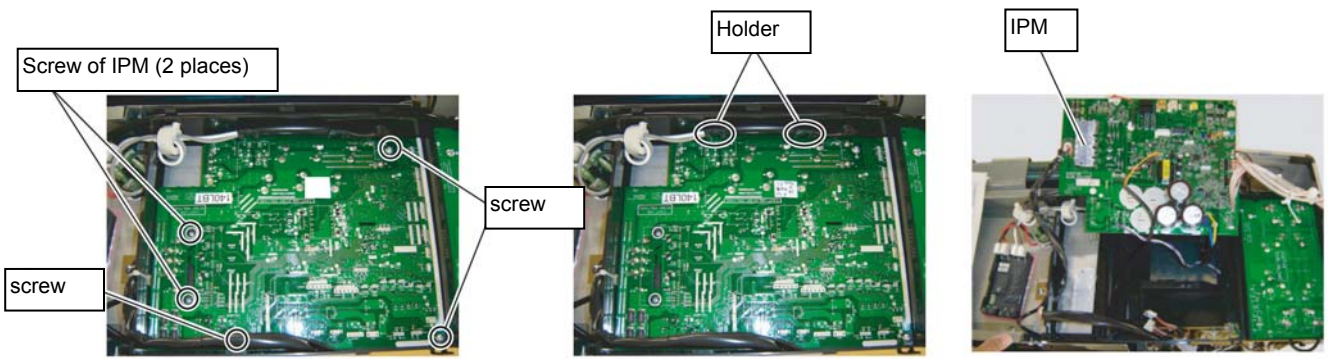

Remove the connectors and screws  
For screws of IPM.  
Note the tightening torque at the installation.  
Tightening torque is 1.2~0.2N.M

Remove the MAIN PCB

Spread the heat dissipation compound on the other side of IPM when you exchange INVERTER PCB by the repair.

### FILTER PCB removal

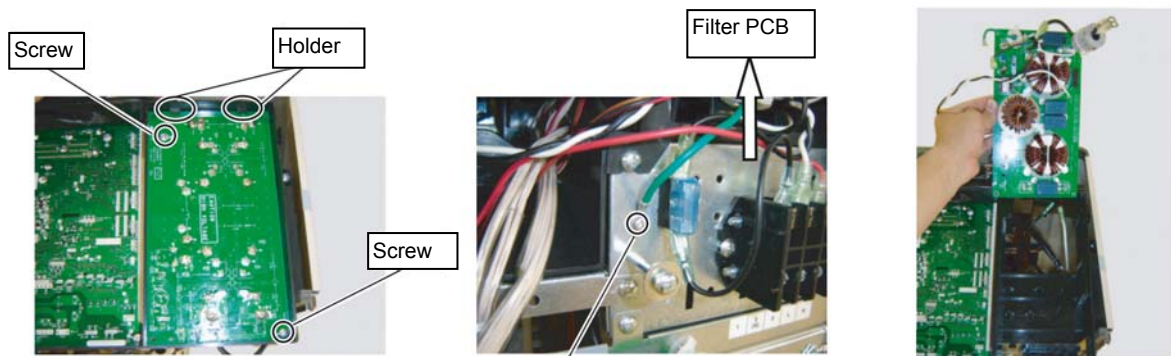

Remove the connectors and screws

Remove the earth screw.

Remove the FILTER PCB.

### INDICATOR PCB removal

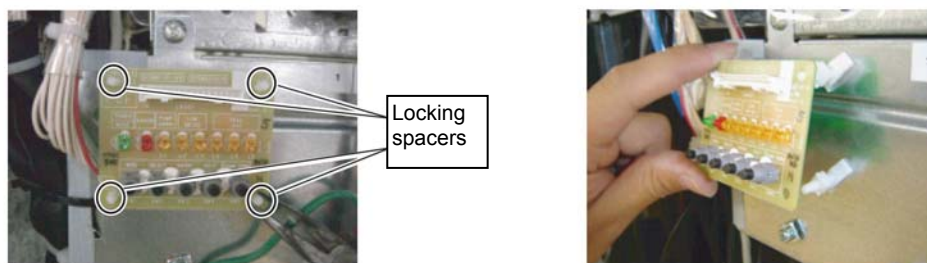

Remove the connectors and locking spacers.

Remove the INDICATOR PCB.

### 6.1.5 FAN MOTOR removal



Remove the 4 mounting screws.

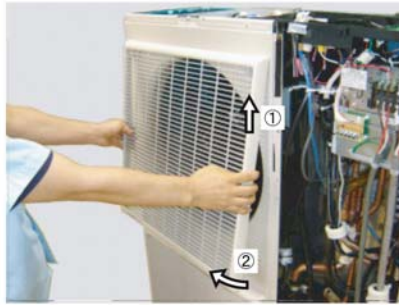

Remove the FAN GUARD by sliding upward.



Remove the Hex Socket Screw. And remove the PROPELLER FAN. Note at the installation. Insert propeller Fan and Motor shaft reference D cutting position. And the tightening torque at the installation. Tightening torque is from 10 to 15 N.M.

Single Phase type

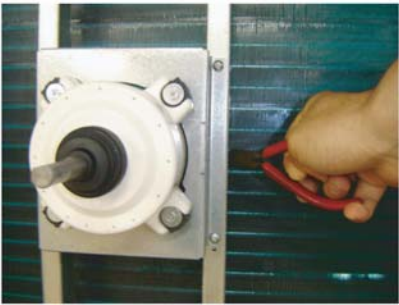

Cut the binder. (2 places)

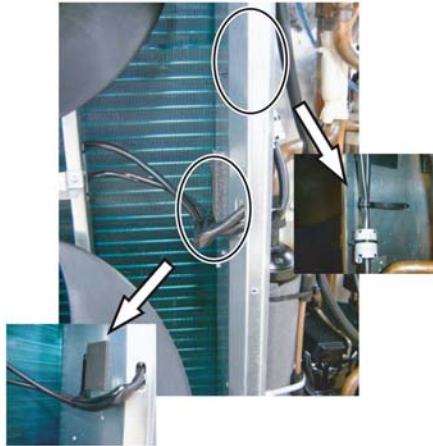

Loose the clamp. (2 places) and remove the lead wires.



Remove the 4 mounting screws. Remove the FAN MOTOR.

### 6.1.6 VALVE COVER removal

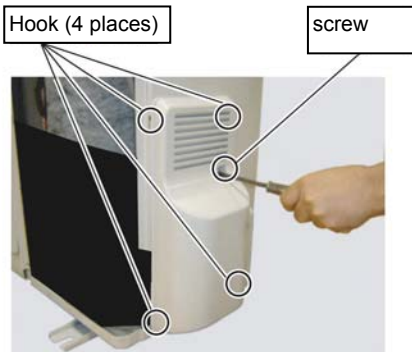

Remove the mounting screws



Remove the VALVE COVER.



### 6.1.7 RIGHT PANEL removal

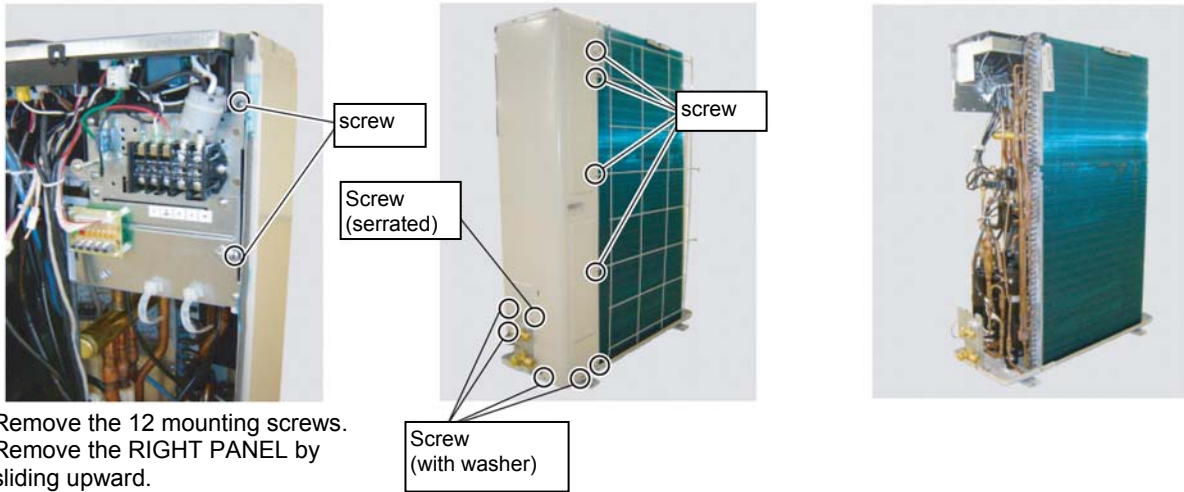

### 6.1.8 THERMISTOR removal

#### HEAT EXCHANGER (MID) THERMISTOR

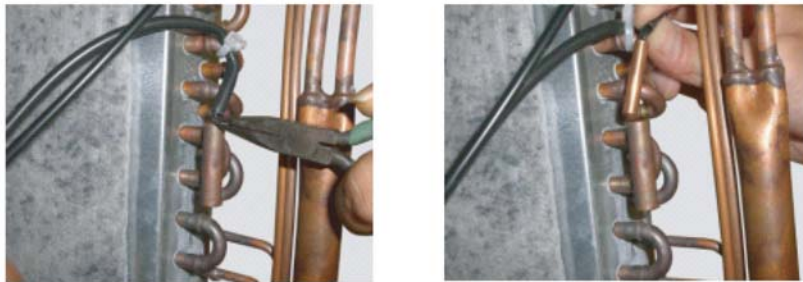

Remove the THERMISTOR SPRING. Remove the THERMISTOR.

#### HEAT EXCHANGER (OUT) THERMISTOR



Remove the THERMISTOR SPRING. Remove the THERMISTOR.

### EEV THERMISTOR



Remove the THERMISTOR SPRING.



Remove the THERMISTOR.

### OUTDOOR THERMISTOR



Remove the THERMOR HOLDER.

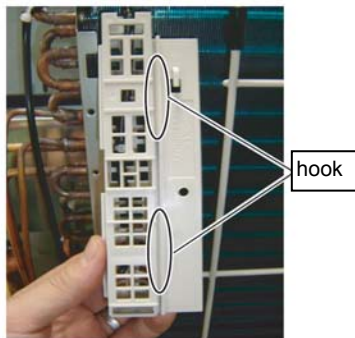

hook



Open the THERMO HOLDER and remove the THERMISTOR.

## 6.1.9 SOLENOID COIL removal

### 4WAY VALVE



Remove the mounting screw.



Remove the SOLENOID COIL.

### INJECTION



Remove the mounting screw.



Remove the SOLENOID COIL.

### 6.1.10 EEV COIL removal

#### MAIN



Remove the EEV coil by hand.

#### INJECTION



Remove the EEV coil by hand.

### 6.1.11 PRESSURE SENSOR removal



Remove the PRESSURE SENSOR with wrench.  
Note the tightening at the installation.  
Tightening torque is 12+-1.5N.m.

> **Warning !** <

Wear gloves to prevent the frostbite, because a small amount of refrigerant leaks during work.

### 6.1.12 COMPRESSOR removal

#### Precautions for exchange of compressor.

Do not allow moisture or debris to get inside refrigerant pipes during work.

#### Procedure for compressor removal.

- 1 Turn off the power
  - 2 Remove the service panel and right panel
  - 3 Fully close the 3Way valve (gas) and 3Way valve (liquid)
  - 4 Collect the refrigerant from the 3Way valve.
- Start the following work after completely collecting the refrigerant.  
Do not reuse the refrigerant that has been collected.

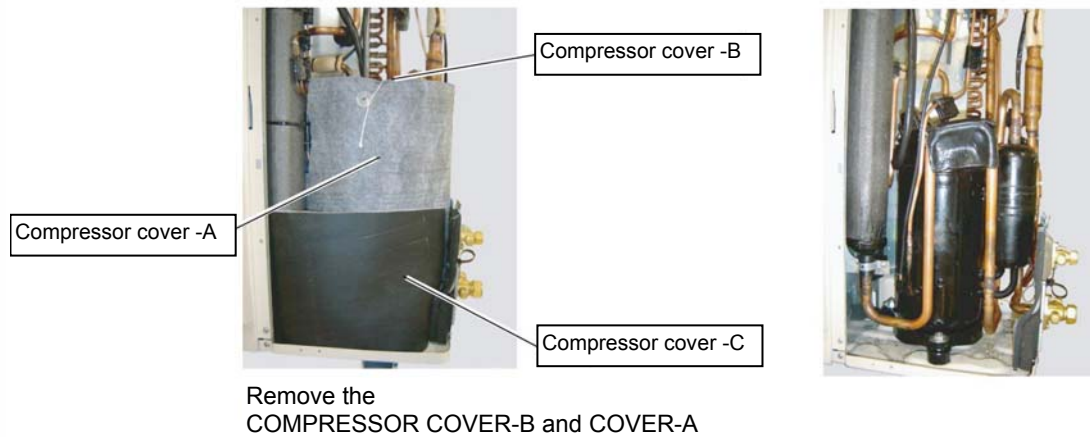

Remove the TERMINAL COVER.



Remove the connectors.  
[R : RED, C(T) : BLACK, S(W) : WHITE]

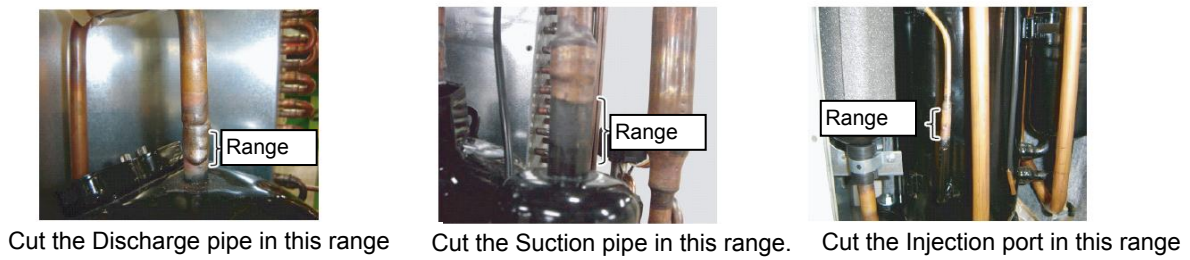
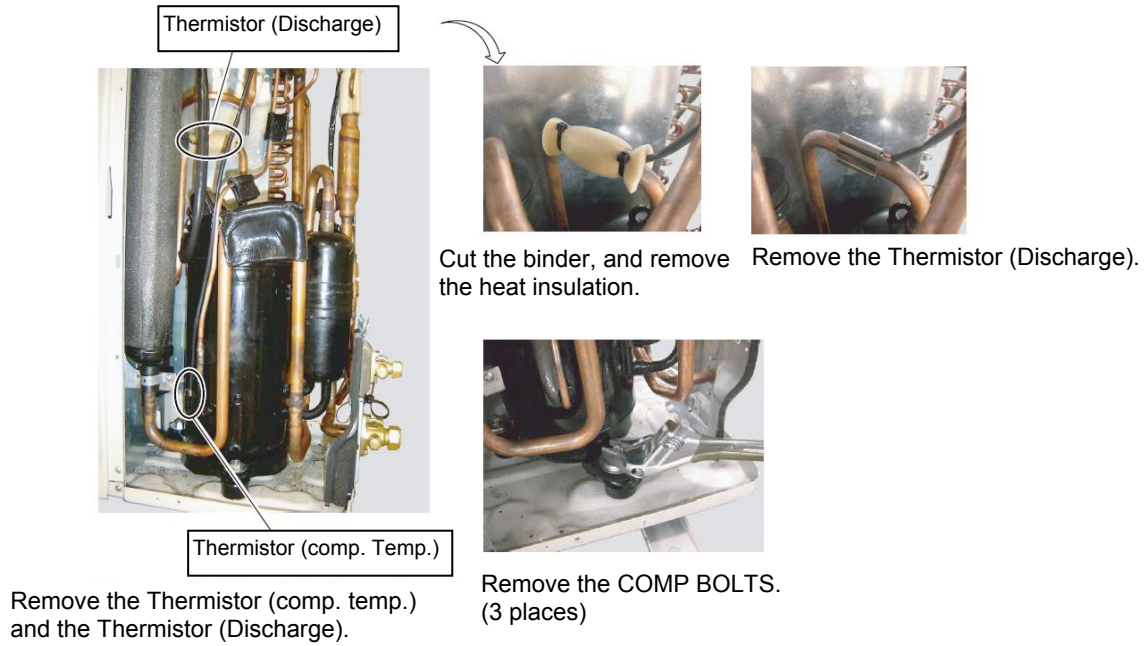

- Keep their shape better.
- There is a possibility of catching fire to oil when removing by the welding without cutting it.

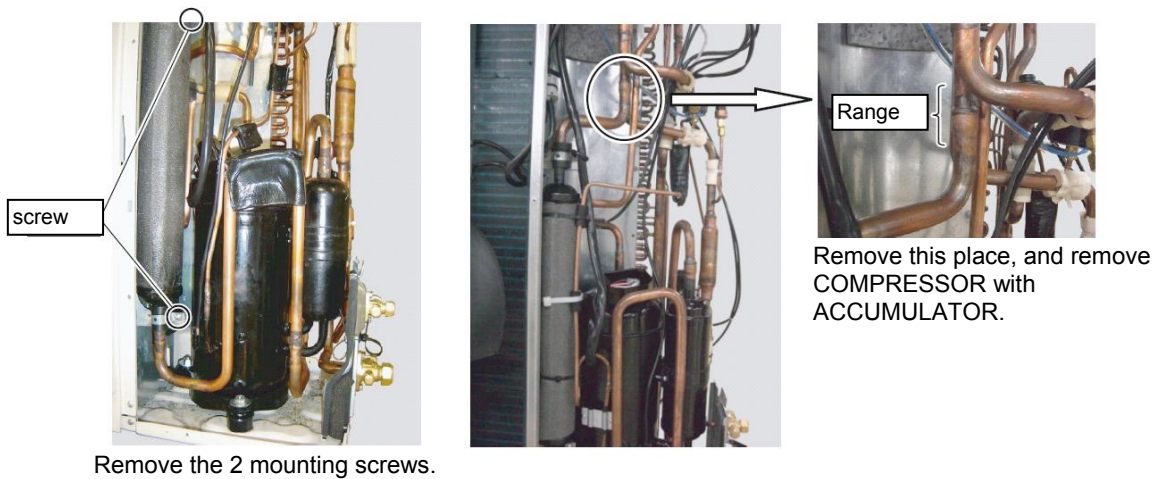

**Procedure for compressor installation**

Reverse procedure to removing the compressor.

**Precautions for installation of compressor.**

- 1 When brazing, do not apply the flame on the terminal.
- 2 When brazing, be sure to replace the air in the pipe with nitrogen gas to prevent forming oxidization scale.

## 6.2 3-phase type

### 6.2.1 Appearance



### 6.2.2 Service panel removal

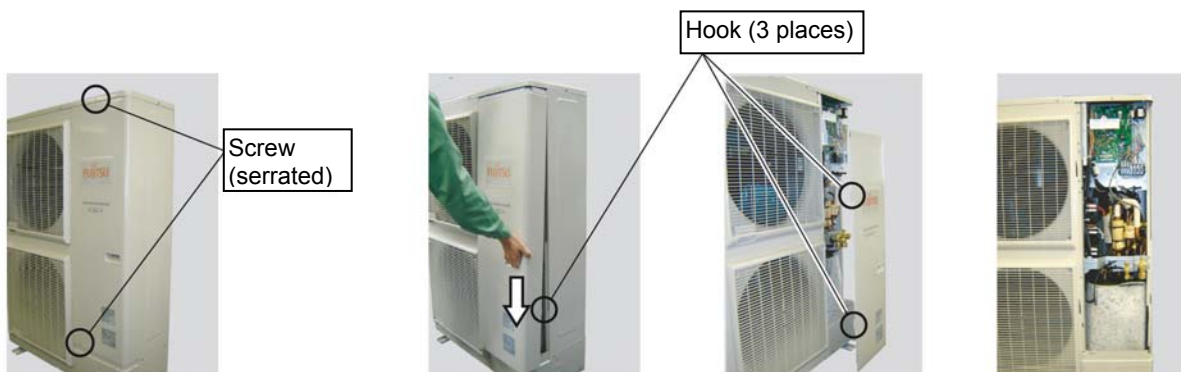

Remove the mounting screws.

Remove the SERVICE PANEL by sliding downward.

### 6.2.3 Insulation sheet removal

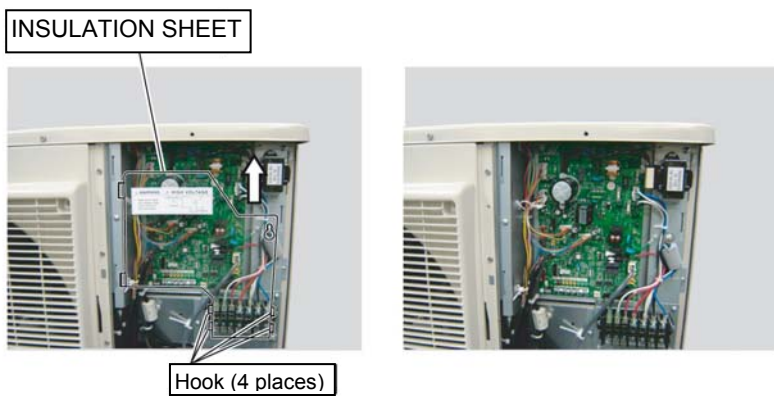

Remove the Hook (4 places)  
Remove the INSULATION SHEET by sliding upward.

### 6.2.4 Main PCB removal

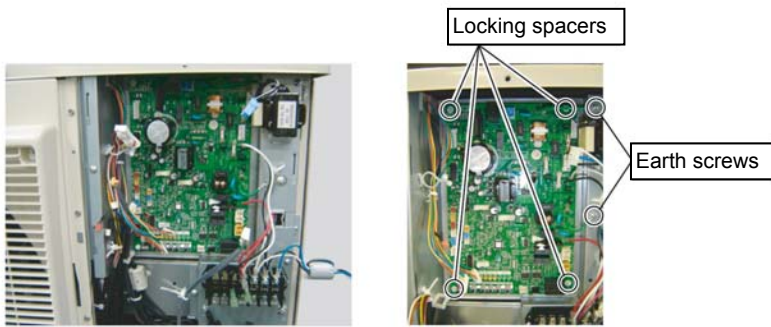

Remove the connectors.

Remove the earth screws and the locking spacers

### 6.2.5 INVERTER, PFC, FILTER, and CAPACITOR PCB removal

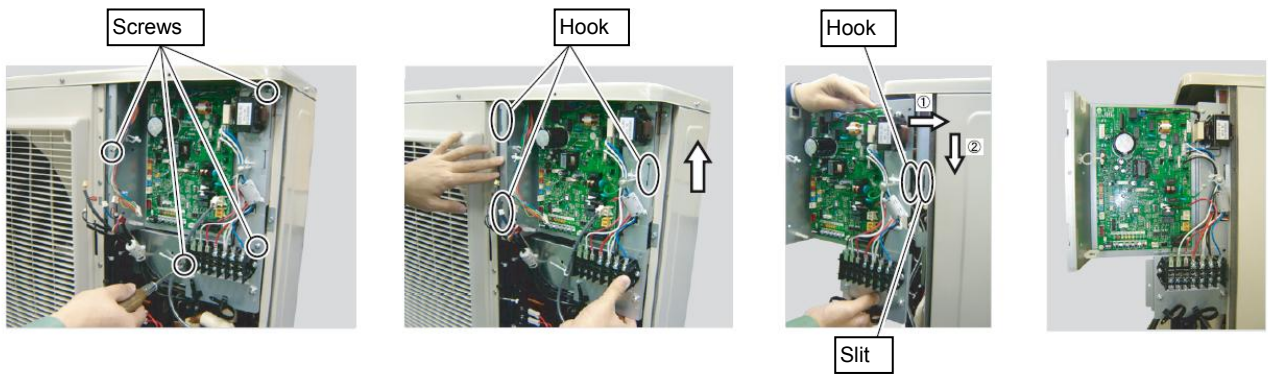

Remove the 4 mounting screws.

Remove the INVERTER CASE MAIN by slidding upward.

Hang the hook on the slit.

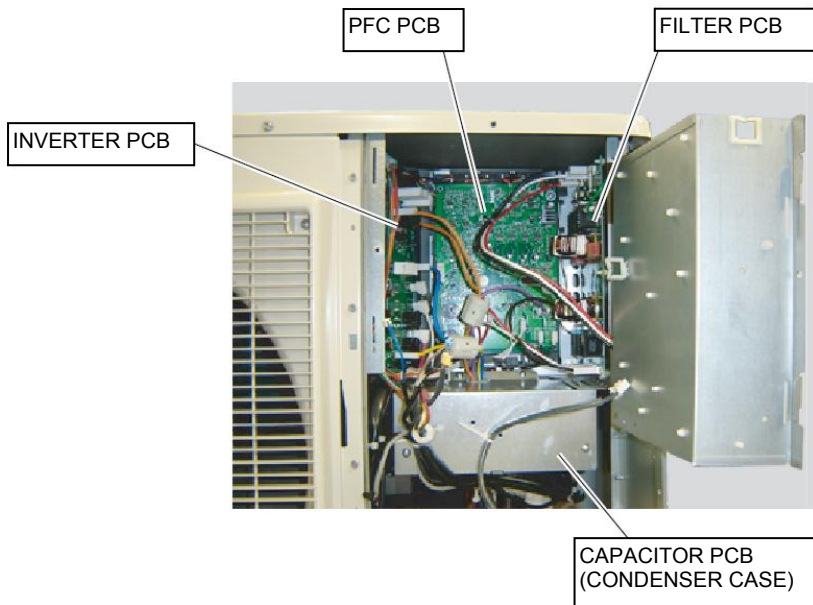

**INVERTER PCB removal**

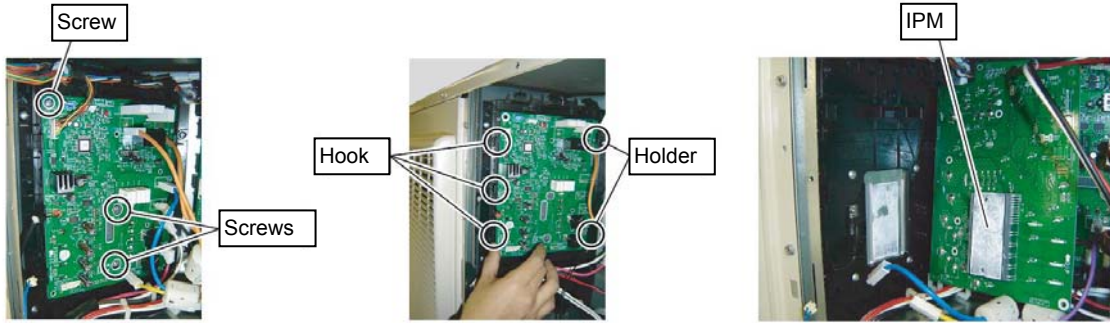

Remove the connectors and screws  
 For screws of IPM.  
 Note the tightening torque at the installation.  
 Tightening torque is 1.2~0.2N.M

Remove the INVERTER PCB.

Spread the heat dissipation compound on the other side of IPM when you exchange INVERTER PCB by the repair.

**PFC PCB removal**

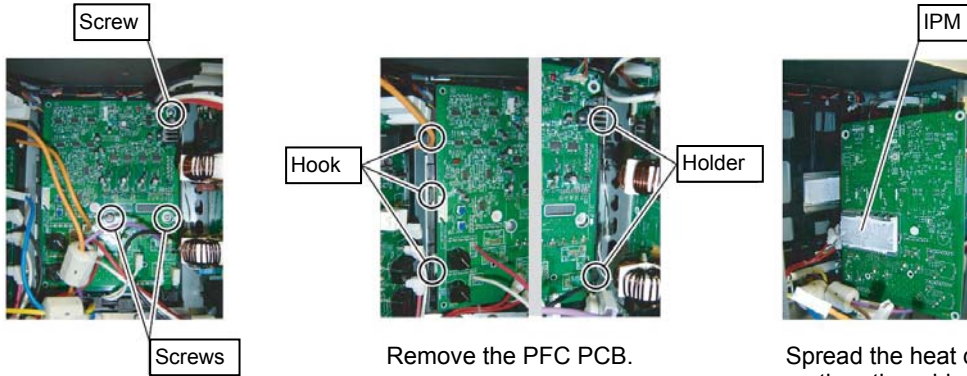

Remove the connectors and screws  
 For screws of IPM.  
 Note the tightening torque at the installation.  
 Tightening torque is 1.2~0.2N.M

Remove the PFC PCB.

Spread the heat dissipation compound on the other side of IPM when you exchange PFC PCB by the repair.

**FILTER PCB removal**

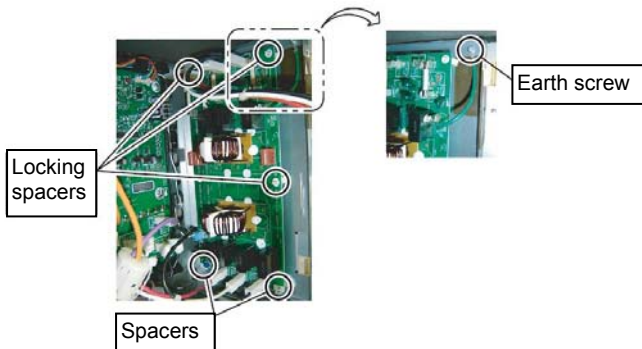

Remove the connectors, locking spacers, spacers, and earth screw.

3-Phase type



**CAPACITOR PCB removal**

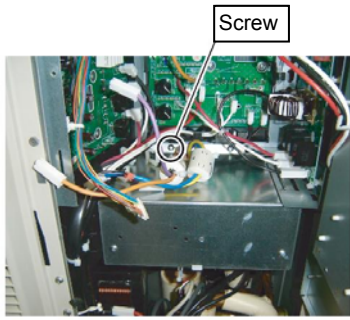

Remove the connectors, codes and screw.

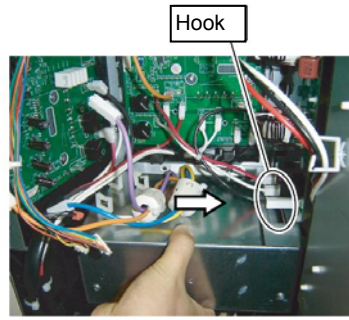

Remove the CONDENSER CASE by sliding rightward.

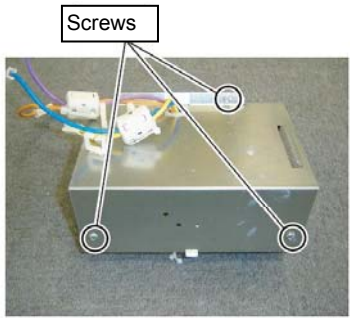
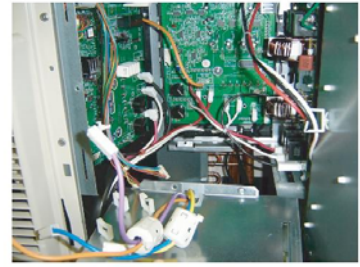

Remove the mounting screws.



Remove the CONDENSER COVER by sliding toward.

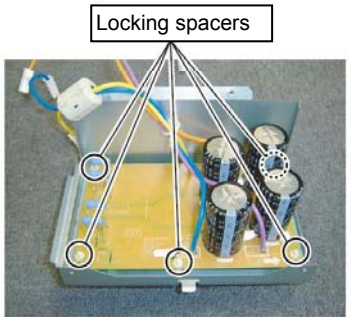
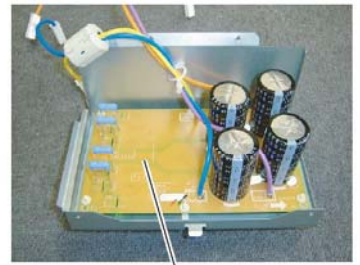

Remove the locking spacers.

### 6.2.6 FAN MOTOR removal



Remove the 4 mounting screws.

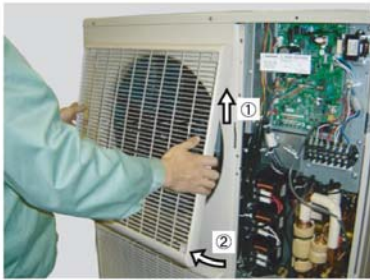

Remove the FAN GUARD by sliding upward.



Remove the Hex Socket Screw and remove the PROPELLER FAN.  
 Note at the installation. Insert propeller Fan and Moter shaft reference D cutting position. And the tightening torque at the installation. Tightening torque is from 10 to 15Nm.

3-Phase type



Cut the binder.(2 places)



Loose the clamp, and remove the lead wires



Remove the 4 mounting screws. Remove the FAN MOTOR.

### 6.2.7 TOP PANEL removal

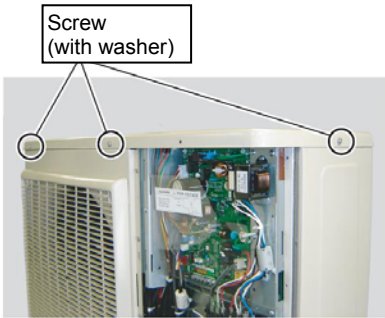

Remove the mounting screws.

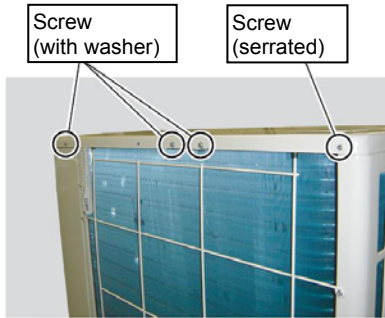

Remove the TOP PANEL.

### 6.2.8 PIPE COVER FRONT removal

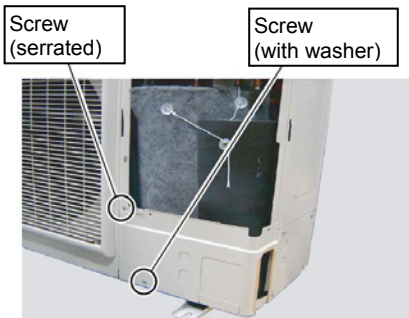

Remove the mounting screws.

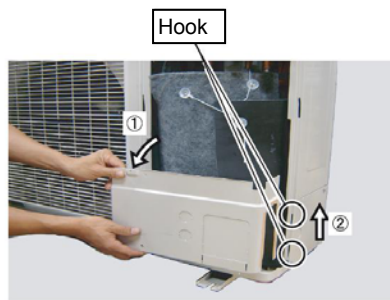

Remove the PIPE COVER FRONT.



### 6.2.9 RIGHT PANEL removal

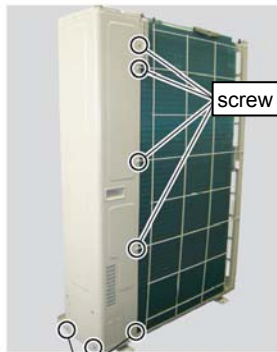
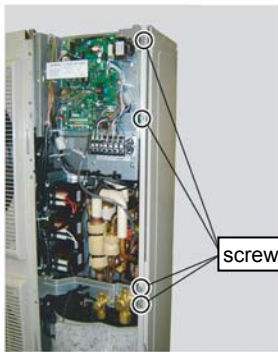

Remove the 11 mounting screws.  
Remove the RIGHT PANEL by sliding upward.

Screw  
(with washer)

### 6.2.10 REACTOR removal



Remove the connectors.



Remove the 3 mounting screws.

### 6.2.11 THERMISTOR removal

#### HEAT EXCHANGER (MID) THERMISTOR



Remove the THERMISTOR SPRING.



Remove the THERMISTOR.

#### HEAT EXCHANGER (OUT) THERMISTOR



Remove the THERMISTOR SPRING.



Remove the THERMISTOR.

### EXPANSION VALVE THERMISTOR



Remove the THERMISTOR SPRING. Remove the THERMISTOR.

### OUTDOOR THERMISTOR



Remove the THERMOR HOLDER.

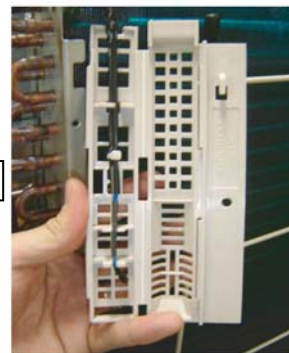
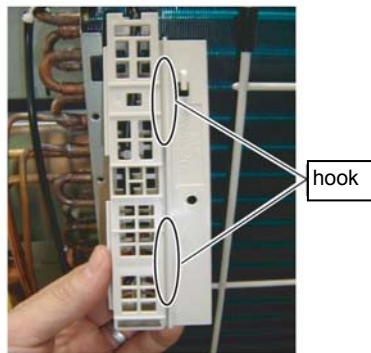

Open the THERMO HOLDER and remove the THERMISTOR.

## 6.2.12 SOLENOID COIL removal

### 4WAY VALVE



Remove the mounting screw.



Remove the SOLENOID COIL.

### INJECTION



Remove the mounting screw.



Remove the SOLENOID COIL.

### 6.2.13 EEV COIL removal

#### MAIN



Remove the EEV coil by hand.

#### INJECTION

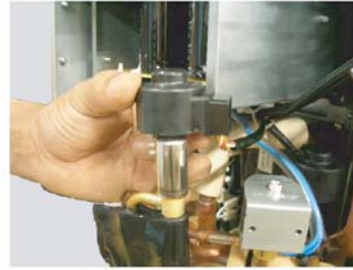

Remove the EEV coil by hand.

### 6.2.14 PRESSURE SENSOR removal



Remove the PRESSURE SENSOR with wrench.

Note the tightening at the installation.  
Tightening torque is 12+-1.5N.m.

**> Warning ! <**

**Wear gloves to prevent the frostbite, because a small amount of refrigerant leaks during work.**

## 6.2.15 COMPRESSOR removal

### Precautions for exchange of compressor.

Do not allow moisture or debris to get inside refrigerant pipes during work.

### Procedure for compressor removal.

- 1 Turn off the power
  - 2 Remove the service panel
  - 3 Fully close the 3Way valve (gas) and 3Way valve (liquid)
  - 4 Collect the refrigerant from the 3Way valve.
- Start the following work after completely collecting the refrigerant.  
Do not reuse the refrigerant that has been collected.

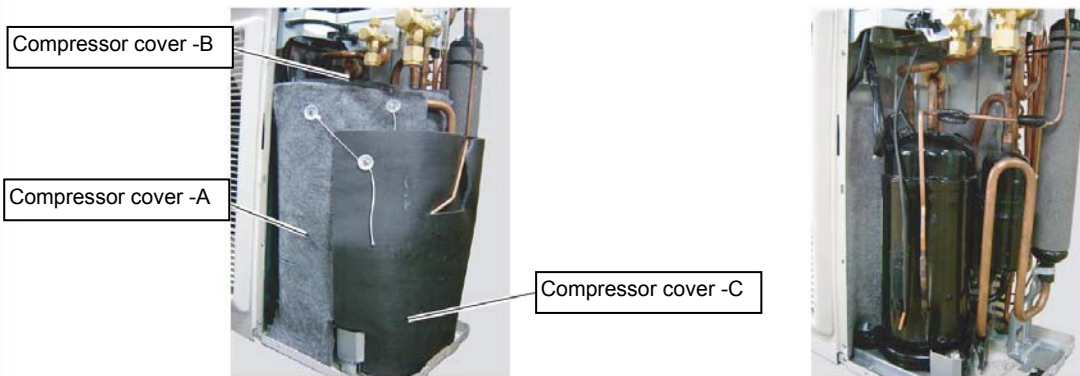

Remove the  
COMPRESSOR COVER-C, COVER-B and COVER-A

---



Remove the TERMINAL COVER.



Remove the connectors.  
[R : RED, C(T) : BLACK, S(W) : WHITE]



Thermistor (Discharge)

Thermistor (comp. Temp.)

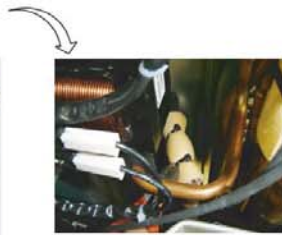

Cut the binder, and remove the heat insulation.



Remove the Thermistor (Discharge).

Remove the Thermistor (comp. temp.) and the Thermistor (Discharge).



Remove the COMP BOLTS. (3 places)

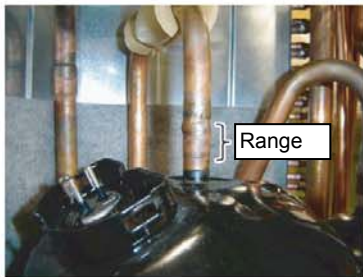

Cut the Discharge pipe in this range

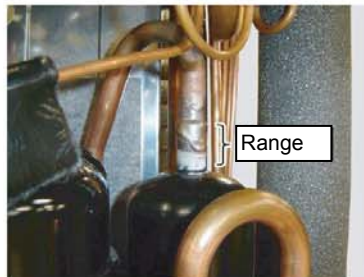

Cut the Suction pipe in this range. Remove the COMPRESSOR.

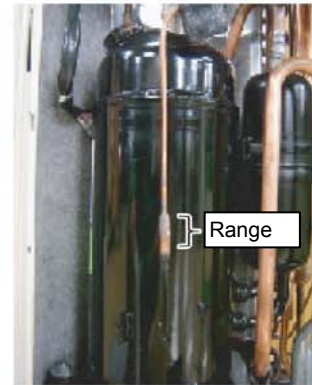

Cut the Injection port in this range

- Keep their shape better.
- There is a possibility of catching fire to oil when removing by the welding without cutting it.

**Procedure for compressor installation**

Reverse procedure to removing the compressor.

**Precautions for installation of compressor.**

- 1 When brazing, do not apply the flame on the terminal.
- 2 When brazing, be sure to replace the air in the pipe with nitrogen gas to prevent forming oxidization scale.

**6.3 Precautions for exchange of refrigerant-cycle-parts**

- (1) During exchange the following parts shall be protected by wet rag and not make the allowable temperature or more.
- (2) Remove the heat insulation when there is the heat insulation near the welding place. Move and cool it when its detaching is difficult.
- (3) Cool the parts when there are parts where heat might be transmilled besides the replacement part.
- (4) Interrupt the flame with the fire-retardant board when the flame seems to hit the following parts directly.
- (5) Do no allow moisture or debris to get inside refrigerant pipes during work.
- (6) When brazing, be sure to replace the air in the pipe with nitrogen gas to prevent forming oxidization scale.

Part name	Allowable temperature	Precautions in work
EXPANSION VALVE (MAIN)	120°C	Remove the coil before brazing. And install the coil after brazing. Detaching necessity sensor.
EXPANSION VALVE (INJECTION)	120°C	Remove the coil before brazing. And install the coil after brazing
4 WAY VALVE	120°C	Remove the suction temp. sensor before brazing. And install the suction temp. sensor after brazing.
3 WAY VALVE (GAS)	100°C	
3 WAY VALVE (LIQUID)		
UNION JOINT	100°C	Remove the pressure sensor before brazing. And install the pressure sensor after brazing.
PRESSURE SENSOR	100°C	Tighten the flare part gripping it. (Tightening torque : 12+-1.5N.m) Do the static electricity measures.
SOLENOID VALVE	200°C	Remove the coil before brazing. And install the coil after brazing.