



AIR CONDITIONER  
**Wall Mounted type**

# DESIGN & TECHNICAL MANUAL

---

---

INDOOR



AS\*G09LMCB  
AS\*G12LMCB  
AS\*G14LMCB

---

OUTDOOR



AO\*G09LMCBN  
AO\*G12LMCBN

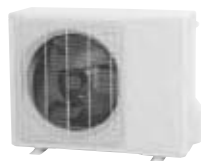

AO\*G14LMCBN

---

**FUJITSU GENERAL LIMITED**

# 1. INDOOR UNIT

---

**WALL MOUNTED TYPE :**

**AS\*G09LMCB**

**AS\*G12LMCB**

**AS\*G14LMCB**

# CONTENTS

---

## 1. INDOOR UNIT

---

<b>1. FEATURES</b> .....	01 - 01
<b>2. WIRELESS REMOTE CONTROLLER</b> .....	01 - 03
<b>3. SPECIFICATIONS</b> .....	01 - 05
<b>4. DIMENSIONS</b> .....	01 - 07
<b>5. WIRING DIAGRAMS</b> .....	01 - 09
<b>6. CAPACITY TABLE</b> .....	01 - 10
6-1. COOLING CAPACITY.....	01 - 10
6-2. HEATING CAPACITY.....	01 - 11
<b>7. FAN PERFORMANCE</b> .....	01 - 12
7-1. AIR VELOCITY DISTRIBUTION.....	01 - 12
7-2. AIRFLOW.....	01 - 14
<b>8. OPERATION NOISE (SOUND PRESSURE)</b> .....	01 - 16
8-1. NOISE LEVEL CURVE.....	01 - 16
8-2. SOUND LEVEL CHECK POINT.....	01 - 18
<b>9. ELECTRICAL CHARACTERISTICS</b> .....	01 - 19
<b>10. SAFETY DEVICES</b> .....	01 - 20
<b>11. EXTERNAL INPUT &amp; OUTPUT</b> .....	01 - 21
11-1. EXTERNAL INPUT.....	01 - 21
11-2. EXTERNAL OUTPUT.....	01 - 23
<b>12. FUNCTION SETTINGS</b> .....	01 - 25
<b>13. OPTIONAL PARTS</b> .....	01 - 30
13-1. CONTROLLERS.....	01 - 30
13-2. OTHERS.....	01 - 30

# 1. FEATURES

## MODELS

AS\*G09LMCB / AO\*G09LMCBN  
 AS\*G12LMCB / AO\*G12LMCBN  
 AS\*G14LMCB / AO\*G14LMCBN

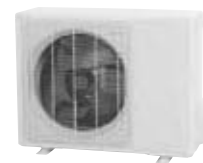

AO\*G09LMCBN  
AO\*G12LMCBN

AO\*G14LMCBN

## FEATURES

### Energy efficiency class

	MODEL		
	AS*G09LMCB	AS*G12LMCB	AS*G14LMCB
Cooling	A++	A++	A++
Heating (Average)	A+	A+	A+

### High efficient compact design

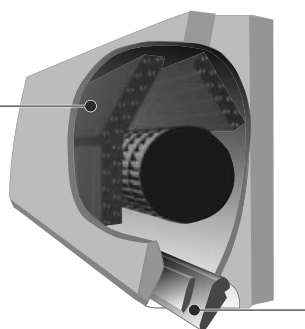
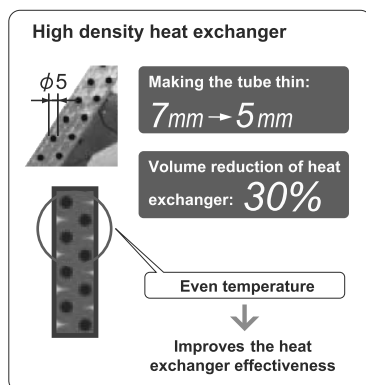

### More comfortable airflow

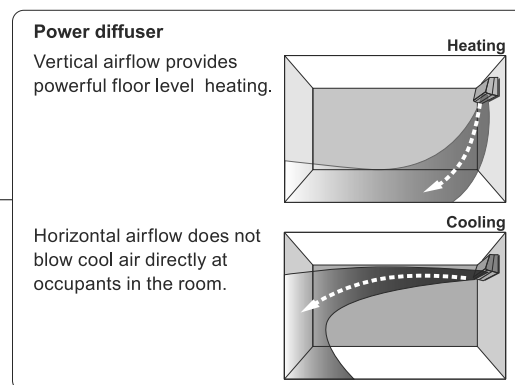

### Quiet operation

#### INDOOR UNIT

Airflow mode can be set in 4 steps and more detailed airflow setting is possible.

\*21dB only at cooling operation (22dB at heating operation)

Fan speed	Noise level
Quiet	21dB(A)

(AS\*G09/12LMCB)

### Outdoor unit low noise

When air-conditioner operates in large capacity, operation noise of outdoor unit will be suppressed. \* In case of room temperature being close to setting temperature, operation noise may not decrease.

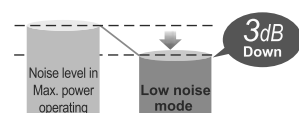

## ● 10°C HEAT Operation

The room temperature can be set to go no lower than 10°C, thus ensuring that the room does not get too cold when not occupied.

NOTE:

- When the room temperature is higher than 10°C, "10°C HEAT" operation will not start. Operation starts and maintains the room temperature at 10°C when the temperature drops below 10°C.

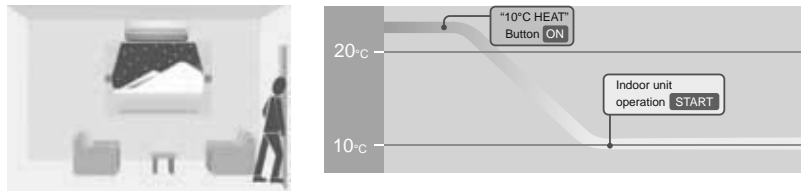

## ● Powerful operation

20 minutes continuous operation by maximum airflow and maximum compressor speed is possible. Rapid cooling and heating makes the room comfortable quickly.

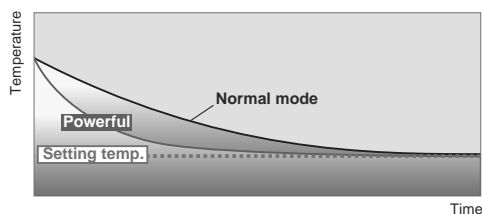

## ● Economy operation

Example : Cooling operation

- Economy operation is energy saving, as the set temperature of indoor unit is shifted by 1°C and the maximum electric value of the outdoor unit is suppressed.

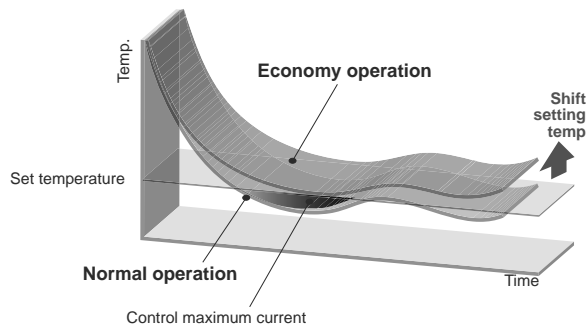

## ● Low outdoor air temperature correspondence

Corresponds to cooling operation at 10°C outdoor air temperature  
Corresponds to heating operation at -25°C outdoor air temperature

Cooling	Heating
10 to 43°C	-25 to 24°C

## ● Corresponds to maximum 20m long piping

## 2. WIRELESS REMOTE CONTROLLER

### ■ FEATURES



- \* 4 mode timer setup available (ON / OFF / PROGRAM / SLEEP).
- \* Easy operation.
- \* Easy to change custom code (max. 4 custom codes) by button operation.

#### ● Simple function setting

Setting of the air conditioner selection function is performed by remote controller.

#### ● Built-in timers

Select from four different timer programs (On / Off / Program / Sleep).

#### ● Program timer

The program timer operates the on and off timer once within a 24 hour period.

#### ● Sleep timer

The sleep timer function automatically corrects the temperature thermostat setting according to the timer setting to prevent excessive cooling and heating while sleeping.

##### Cooling operation/dry operation

When the sleep timer is set, the set temperature automatically rises 1 °C every hour. The set temperature can rise up to a maximum of 2 °C.

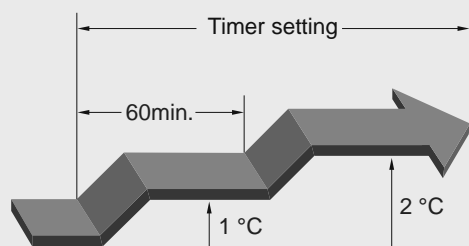

##### Heating operation

When the sleep timer is set, the set temperature automatically drops 1 °C every 30 minutes. The set temperature can drop to a maximum of 4 °C.

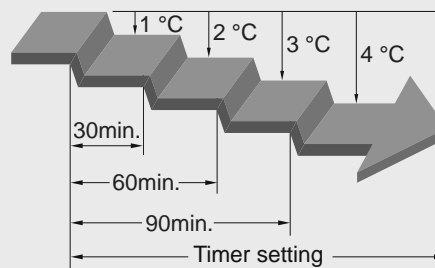

#### ● Switching remote controller custom code

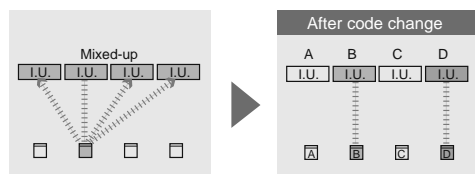

- Code selector switch eliminates unit being wrongly switched.  
(Up to 4 custom codes can be set.)

\*I.U.=Indoor unit

## FUNCTIONS

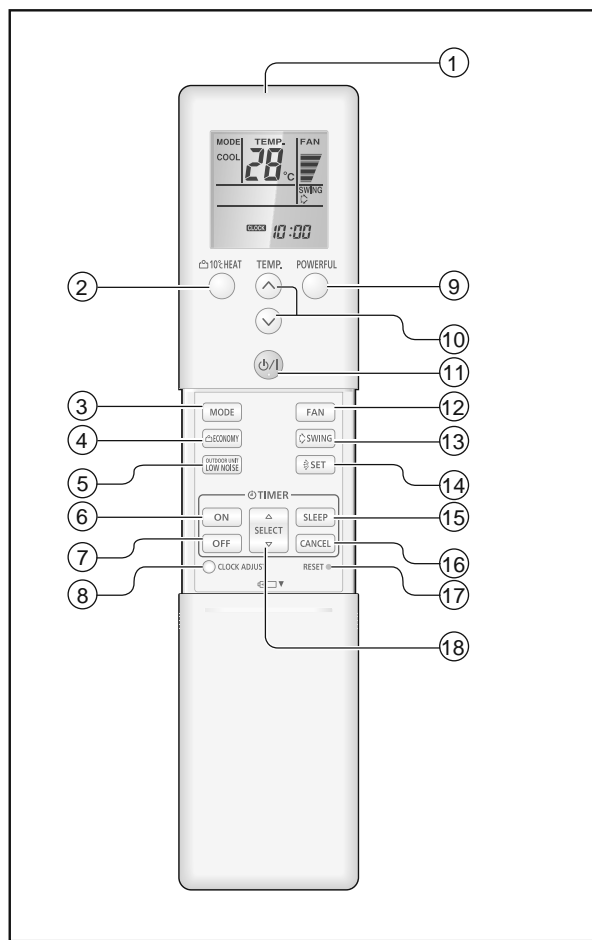

- ① Signal Transmitter
- ② 10 °C HEAT button
- ③ MODE button
- ④ ECONOMY button
- ⑤ OUTDOOR UNIT LOW NOISE button
- ⑥ ON TIMER button
- ⑦ OFF TIMER button
- ⑧ CLOCK ADJUST button
- ⑨ POWERFUL button
- ⑩ TEMP. Set button ( ▲ / ▼ )
- ⑪ Start/Stop button
- ⑫ FAN button
- ⑬ SWING button
- ⑭ SET button
- ⑮ SLEEP TIMER button
- ⑯ CANCEL button
- ⑰ RESET button
- ⑱ TIMER SELECT button ( ▲ / ▼ )

Display panel

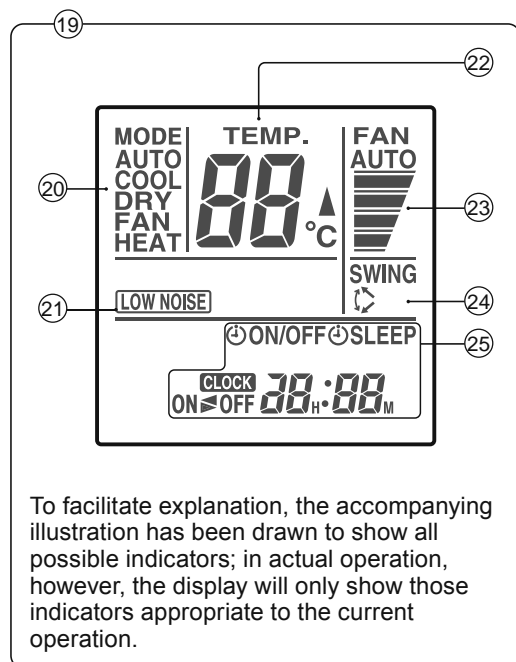

- ⑲ Remote Controller Display
- ⑳ Operation Mode indicator
- ㉑ Low Noise Mode indicator
- ㉒ Temperature Set indicator
- ㉓ Fan Speed indicator
- ㉔ Swing indicator
- ㉕ Clock & Timer indicator

**NOTE:**

Some button operations may not be available for all units or systems, refer to the operation manual.

## SPECIFICATION

SIZE	(H x W x D mm)	205 x 61 x 17
WEIGHT	( g )	122
ACCESSORY		Holder

### 3. SPECIFICATIONS

Type				WALL MOUNTED		
				INVERTER HEAT PUMP		
Model name				AS*G09LMCB	AS*G12LMCB	AS*G14LMCB
Power source				230V~ 50Hz		
Available voltage range				198-264V~ 50Hz		
Capacity	Cooling	Rated	kW	2.50	3.40	4.20
			Btu/h	8,500	11,600	14,300
		Min - Max	kW	0.5 - 3.2	0.9 - 4.15	1.1 - 4.8
			Btu/h	1,700 - 10,900	3,100 - 14,100	3,700 - 16,300
	Heating	Rated	kW	3.20	4.00	5.40
			Btu/h	10,900	13,600	18,400
Min - Max		kW	0.5 - 5.2	0.9 - 5.7	1.1 - 6.0	
		Btu/h	1,700 - 17,700	3,100 - 19,400	3,700 - 20,400	
Input power	Cooling	kW	Rated	0.630	0.925	1.205
			Min - Max	0.25 - 1.41	0.25 - 1.64	0.25 - 2.09
	Heating		Rated	0.730	0.990	1.560
			Min - Max	0.25 - 2.21	0.25 - 2.55	0.25 - 2.66
Current	Cooling	Rated	A	3.2	4.4	5.6
	Heating		3.7	4.7	7.1	
EER	Cooling	kW/kW		3.97	3.68	3.49
COP	Heating			4.38	4.04	3.46
Sensible capacity	Cooling	kW		1.60	2.20	2.70
Power factor	Cooling	%		87	91	93
	Heating			89	92	95
Moisture removal			l/h(pints/h)	1.3 (2.3)	1.8 (3.2)	2.1 (3.7)
Maximum operating current *		Cooling	A		6.0	7.0
		Heating			9.5	11.0
Fan	Airflow rate	Cooling	High	m <sup>3</sup> /h	750	
			Med		640	
			Low		480	
			Quiet		310	
		Heating	High		750	
			Med		640	
			Low		520	
			Quiet		330	
	Type x Q'ty		Crossflow fan x 1			
	Motor output		W	30		
Sound pressure level	Cooling	dB(A)	High	43		
			Med	40		
			Low	32		
			Quiet	21		
	Heating		High	43		
			Med	38		
			Low	33		
			Quiet	22		
Heat exchanger type	Dimensions (H x W x D)	mm	Main:320 x 630 x 20 Sub:84 x 630 x 13.3			
	Fin pitch		Main:1.1, Sub:1.4			
	Rows x Stages		Main:2 x 20, Sub:1 x 4			
	Pipe type		Copper			
	Fin type		Aluminium			
Enclosure	Material	Polystyrene				
	Colour	White (Approximate colour of MUNSELL N9.25/)				
Dimensions (H x W x D)	Net	mm	268 x 840 x 203			
	Gross		270 x 884 x 336			
Weight	Net	kg	8.5			
	Gross		10.5			
Connection pipe	Size	Liquid	Ø 6.35 (Ø 1/4 in.)			
		Gas	Ø 9.52 (Ø 3/8 in.)		Ø 12.7 (Ø 1/2 in.)	
	Method	Flare				
Operation range	Cooling	°C	18 to 32			
		%RH	80 or less			
	Heating	°C	16 to 30			
Remote controller type				Wireless		
Drain hose	Material	PP + LLDPE				
	Size	mm	Ø 13.8 (I.D.), Ø 15.8 to Ø 16.7 (O.D.)			

NOTES:

●Specifications are based on the following conditions

Cooling:Indoor temperature of 27°C DB / 19°CWB and outdoor temperature of 35°C DB / 24°CWB.

Heating:Indoor temperature of 20°C DB/15°CWB and outdoor temperature of 7°C DB / 6°CWB.

Pipe length: 5 m, Height difference: 0 m (Outdoor unit - Indoor unit)

●The protective function might work when using it in environment out of the temperature range mentioned above.

\*: The maximum current is the maximum value when operated within the operation range.



Model name		AS*G09LMCB	AS*G12LMCB	AS*G14LMCB
Energy efficiency class	Cooling	A++	A++	A++
	Heating (Average)	A+	A+	A+
Pdesign	Cooling	kW	2.5 (35°C)	3.4 (35°C)
	Heating (Average)		3.0 (-10°C)	3.6 (-10°C)
SEER	Cooling	kWh/kWh	6.50	6.90
SCOP	Heating (Average)		4.10	4.10
Annual energy consumption	QCE	kWh/a	135	173
	QHE (Average)		1024	1230
Sound power level	Cooling	High	dB (A)	59
	Heating			59



# ■ INSTALLATION PLACE

(Unit : mm)

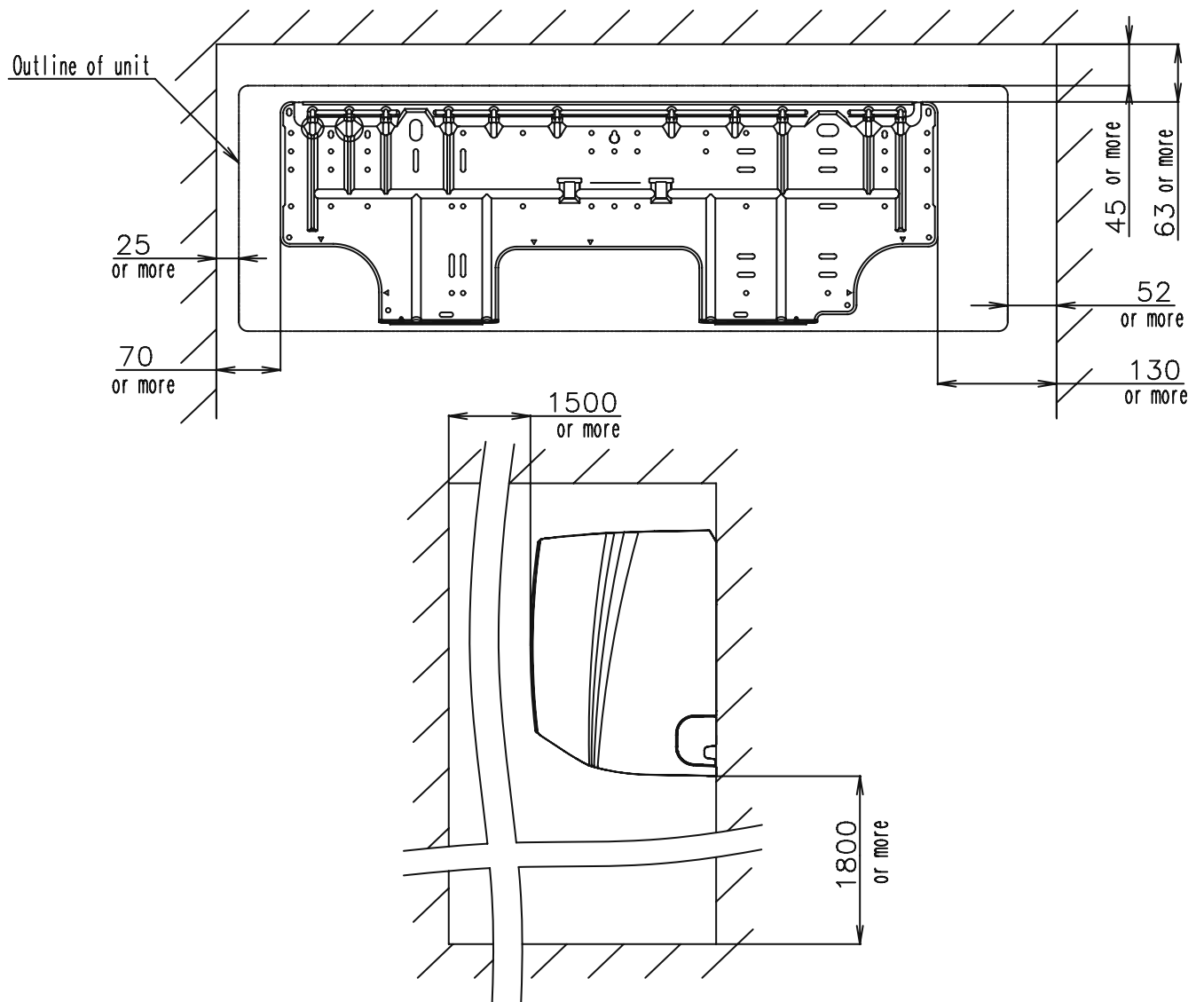

# 5. WIRING DIAGRAMS

■ MODELS: AS\*G09LMCB, AS\*G12LMCB, AS\*G14LMCB

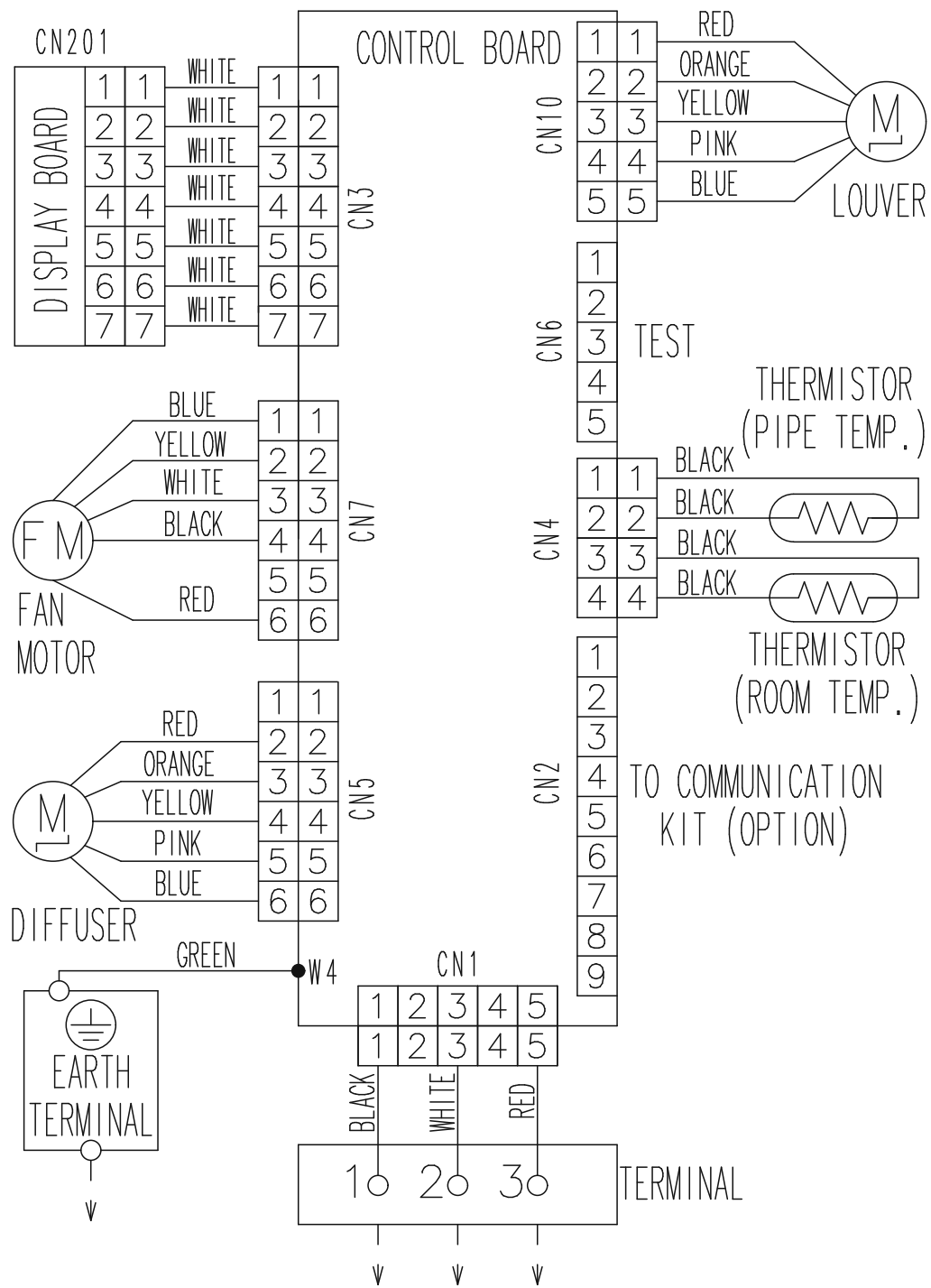

# 6. CAPACITY TABLE

## 6-1. COOLING CAPACITY

### MODEL: AS\*G09LMCB

AFR	12.5
-----	------

		Indoor temperature																							
		18			21			23			25			27			29			32					
		12			15			16			18			19			21			23					
Outdoor temperature	°CDB	TC	SHC	IP	TC	SHC	IP	TC	SHC	IP	TC	SHC	IP	TC	SHC	IP	TC	SHC	IP	TC	SHC	IP			
	10	2.10	1.30	0.26	2.34	1.31	0.27	2.41	1.42	0.27	2.57	1.43	0.27	2.65	1.54	0.27	2.81	1.53	0.28	2.97	1.63	0.28	2.97	1.63	0.28
	15	2.21	1.35	0.28	2.47	1.36	0.29	2.55	1.48	0.29	2.72	1.48	0.29	2.80	1.60	0.29	2.97	1.59	0.30	3.14	1.70	0.30	3.14	1.70	0.30
	20	2.33	1.43	0.43	2.59	1.44	0.43	2.68	1.57	0.44	2.86	1.57	0.44	2.95	1.70	0.44	3.12	1.69	0.45	3.30	1.80	0.45	3.30	1.80	0.45
	25	2.21	1.40	0.49	2.46	1.40	0.49	2.54	1.53	0.50	2.71	1.53	0.50	2.79	1.65	0.50	2.96	1.65	0.51	3.13	1.76	0.51	3.13	1.76	0.51
	30	2.09	1.35	0.55	2.33	1.36	0.56	2.41	1.48	0.56	2.57	1.48	0.56	2.65	1.60	0.57	2.81	1.60	0.57	2.97	1.70	0.58	2.97	1.70	0.58
	35	1.98	1.35	0.61	2.20	1.36	0.62	2.28	1.48	0.62	2.43	1.48	0.63	2.50	1.60	0.63	2.65	1.59	0.64	2.80	1.70	0.64	2.80	1.70	0.64
	40	1.72	1.30	0.67	1.92	1.30	0.68	1.98	1.42	0.68	2.11	1.42	0.69	2.18	1.54	0.69	2.31	1.53	0.70	2.44	1.63	0.71	2.44	1.63	0.71
	43	1.58	1.28	0.71	1.76	1.29	0.72	1.82	1.40	0.72	1.94	1.41	0.73	2.00	1.52	0.73	2.12	1.51	0.74	2.24	1.61	0.75	2.24	1.61	0.75

### MODEL: AS\*G12LMCB

AFR	12.5
-----	------

		Indoor temperature																							
		18			21			23			25			27			29			32					
		12			15			16			18			19			21			23					
Outdoor temperature	°CDB	TC	SHC	IP	TC	SHC	IP	TC	SHC	IP	TC	SHC	IP	TC	SHC	IP	TC	SHC	IP	TC	SHC	IP			
	10	2.49	2.09	0.25	2.78	2.10	0.26	2.87	2.28	0.26	3.06	2.29	0.26	3.16	2.47	0.26	3.35	2.46	0.27	3.54	2.63	0.27	3.54	2.63	0.27
	15	2.84	1.87	0.33	3.16	1.88	0.33	3.27	2.04	0.34	3.49	2.05	0.34	3.59	2.21	0.34	3.81	2.21	0.34	4.03	2.35	0.35	4.03	2.35	0.35
	20	3.15	2.02	0.61	3.51	2.03	0.62	3.63	2.20	0.63	3.87	2.21	0.63	3.99	2.39	0.64	4.23	2.38	0.64	4.47	2.53	0.65	4.47	2.53	0.65
	25	3.01	1.95	0.71	3.35	1.96	0.72	3.47	2.14	0.72	3.69	2.14	0.73	3.81	2.31	0.73	4.04	2.30	0.74	4.26	2.45	0.75	4.26	2.45	0.75
	30	2.85	1.94	0.80	3.18	1.95	0.81	3.28	2.12	0.82	3.50	2.13	0.82	3.61	2.30	0.83	3.83	2.29	0.84	4.04	2.44	0.84	4.04	2.44	0.84
	35	2.69	1.86	0.89	2.99	1.87	0.91	3.09	2.03	0.91	3.30	2.04	0.92	3.40	2.20	0.93	3.60	2.19	0.93	3.81	2.33	0.94	3.81	2.33	0.94
	40	2.50	1.71	0.84	2.79	1.72	0.86	2.89	1.87	0.86	3.08	1.88	0.87	3.17	2.03	0.87	3.36	2.02	0.88	3.55	2.15	0.89	3.55	2.15	0.89
	43	2.31	1.66	0.83	2.57	1.67	0.84	2.66	1.82	0.85	2.83	1.83	0.85	2.92	1.97	0.86	3.10	1.96	0.87	3.27	2.09	0.88	3.27	2.09	0.88

### MODEL: AS\*G14LMCB

AFR	12.8
-----	------

		Indoor temperature																							
		18			21			23			25			27			29			32					
		12			15			16			18			19			21			23					
Outdoor temperature	°CDB	TC	SHC	IP	TC	SHC	IP	TC	SHC	IP	TC	SHC	IP	TC	SHC	IP	TC	SHC	IP	TC	SHC	IP			
	10	3.00	1.66	0.59	3.34	1.67	0.60	3.46	1.82	0.61	3.68	1.83	0.61	3.80	1.97	0.62	4.02	1.96	0.62	4.25	2.09	0.63	4.25	2.09	0.63
	15	3.75	2.55	0.58	4.18	2.57	0.59	4.32	2.79	0.59	4.61	2.80	0.60	4.75	3.03	0.60	5.04	3.01	0.61	5.32	3.21	0.61	5.32	3.21	0.61
	20	3.81	2.61	0.83	4.25	2.63	0.84	4.39	2.86	0.84	4.68	2.87	0.85	4.83	3.09	0.86	5.12	3.08	0.86	5.41	3.28	0.87	5.41	3.28	0.87
	25	3.56	2.52	0.94	3.96	2.53	0.95	4.10	2.75	0.96	4.37	2.76	0.97	4.50	2.98	0.97	4.77	2.97	0.98	5.04	3.16	0.99	5.04	3.16	0.99
	30	3.40	2.41	1.05	3.79	2.42	1.06	3.92	2.64	1.07	4.18	2.64	1.08	4.31	2.86	1.09	4.57	2.84	1.10	4.83	3.03	1.11	4.83	3.03	1.11
	35	3.32	2.36	1.16	3.70	2.38	1.18	3.82	2.58	1.19	4.07	2.59	1.20	4.20	2.80	1.21	4.45	2.79	1.22	4.70	2.97	1.23	4.70	2.97	1.23
	40	2.83	2.31	1.28	3.15	2.32	1.30	3.26	2.52	1.31	3.47	2.53	1.32	3.58	2.73	1.33	3.79	2.72	1.34	4.01	2.90	1.35	4.01	2.90	1.35
	43	2.61	2.25	1.35	2.91	2.27	1.37	3.01	2.46	1.38	3.21	2.47	1.40	3.31	2.67	1.40	3.51	2.66	1.42	3.70	2.83	1.43	3.70	2.83	1.43

AFR : AirFlow Rate (m<sup>3</sup>/min)  
 TC : Total Capacity (kW)  
 SHC : Sensible Heat Capacity (kW)  
 IP : Input Power (kW)

## 6-2. HEATING CAPACITY

### ■ MODEL : AS\*G09LMCB

AFR	12.5
-----	------

Outdoor temperature		Indoor temperature										
		(°CDB)	16		18		20		22		24	
		(°CWB)	TC	IP	TC	IP	TC	IP	TC	IP	TC	IP
-25	-26	2.41	1.46	2.36	1.50	2.30	1.53	2.24	1.56	2.18	1.59	
-20	-21	2.97	1.58	2.90	1.61	2.83	1.65	2.76	1.68	2.69	1.71	
-15	-16	3.36	1.67	3.28	1.70	3.20	1.74	3.12	1.77	3.04	1.81	
-10	-11	4.03	1.78	3.94	1.82	3.84	1.86	3.74	1.89	3.65	1.93	
-5	-7	4.37	1.87	4.26	1.91	4.16	1.95	4.06	1.99	3.95	2.03	
0	-2	4.68	1.90	4.57	1.94	4.46	1.98	4.34	2.02	4.23	2.06	
5	3	5.13	1.78	5.01	1.81	4.88	1.85	4.76	1.89	4.64	1.92	
7	6	5.46	1.71	5.33	1.75	5.20	1.79	5.07	1.82	4.94	1.86	
10	8	5.59	1.60	5.46	1.64	5.33	1.67	5.19	1.70	5.06	1.74	
15	10	5.77	1.46	5.64	1.50	5.50	1.53	5.36	1.56	5.22	1.59	

### ■ MODEL : AS\*G12LMCB

AFR	12.5
-----	------

Outdoor temperature		Indoor temperature										
		(°CDB)	16		18		20		22		24	
		(°CWB)	TC	IP	TC	IP	TC	IP	TC	IP	TC	IP
-25	-26	2.47	1.51	2.41	1.54	2.36	1.57	2.30	1.60	2.24	1.63	
-20	-21	3.19	1.64	3.11	1.67	3.03	1.70	2.96	1.74	2.88	1.77	
-15	-16	3.52	1.77	3.44	1.80	3.35	1.84	3.27	1.88	3.18	1.91	
-10	-11	4.25	1.87	4.14	1.91	4.04	1.95	3.94	1.99	3.84	2.03	
-5	-7	4.58	1.95	4.47	1.99	4.36	2.03	4.25	2.07	4.14	2.11	
0	-2	5.06	2.05	4.94	2.09	4.82	2.13	4.70	2.18	4.58	2.22	
5	3	5.61	1.84	5.47	1.88	5.34	1.92	5.21	1.96	5.07	2.00	
7	6	5.99	1.80	5.84	1.83	5.70	1.87	5.56	1.91	5.42	1.95	
10	8	6.29	1.70	6.14	1.74	5.99	1.77	5.84	1.81	5.69	1.85	
15	10	6.44	1.59	6.28	1.62	6.13	1.65	5.98	1.69	5.82	1.72	

### ■ MODEL : AS\*G14LMCB

AFR	12.8
-----	------

Outdoor temperature		Indoor temperature										
		(°CDB)	16		18		20		22		24	
		(°CWB)	TC	IP	TC	IP	TC	IP	TC	IP	TC	IP
-25	-26	3.65	2.26	3.56	2.30	3.48	2.35	3.39	2.40	3.30	2.44	
-20	-21	4.08	2.27	3.98	2.31	3.89	2.36	3.79	2.41	3.69	2.45	
-15	-16	4.54	2.28	4.43	2.32	4.33	2.37	4.22	2.42	4.11	2.47	
-10	-11	5.15	2.28	5.03	2.33	4.91	2.37	4.79	2.42	4.66	2.47	
-5	-7	5.64	2.27	5.50	2.32	5.37	2.37	5.23	2.42	5.10	2.46	
0	-2	5.81	2.28	5.67	2.33	5.54	2.37	5.40	2.42	5.26	2.47	
5	3	6.03	2.08	5.89	2.12	5.75	2.16	5.60	2.21	5.46	2.25	
7	6	6.30	2.01	6.15	2.06	6.00	2.10	5.85	2.14	5.70	2.18	
10	8	6.41	1.97	6.26	2.01	6.11	2.05	5.95	2.09	5.80	2.13	
15	10	6.35	1.75	6.20	1.79	6.04	1.83	5.89	1.86	5.74	1.90	

AFR : AirFlow Rate (m<sup>3</sup>/min)  
 TC : Total Capacity (kW)  
 IP : Input Power (kW)

# 7. FAN PERFORMANCE

## 7-1. AIR VELOCITY DISTRIBUTION

Conditions:  
Fan speed: HIGH  
Operation mode: FAN

MODELS : AS\*G09LMCB, AS\*G12LMCB

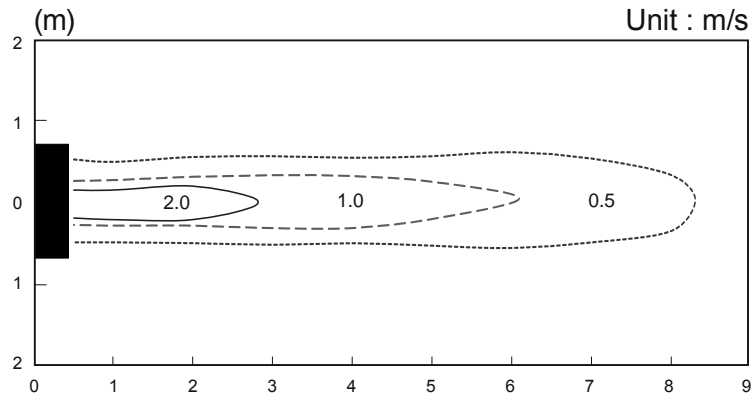

TOP VIEW  
Vertical airflow direction louver: Up  
Horizontal airflow direction louver: Center

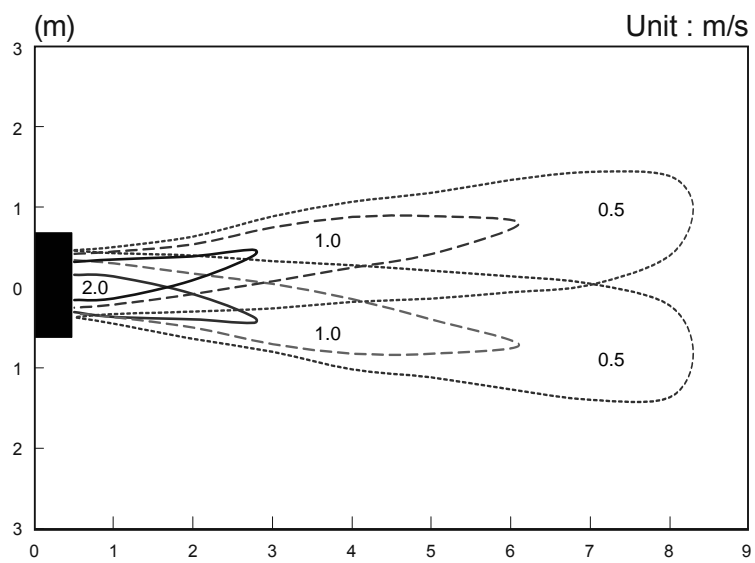

TOP VIEW  
Vertical airflow direction louver: Up  
Horizontal airflow direction louver: Right & Left

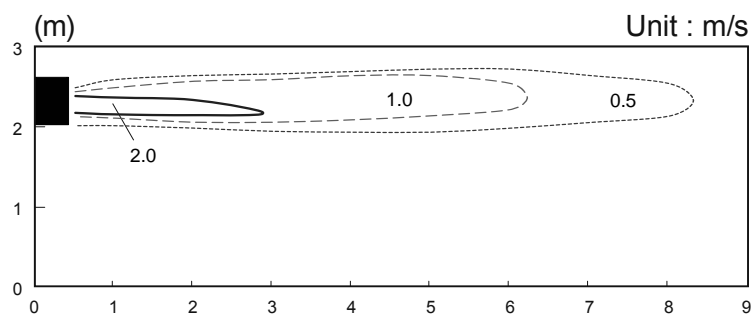

SIDE VIEW  
Vertical airflow direction louver: Up  
Horizontal airflow direction louver: Center

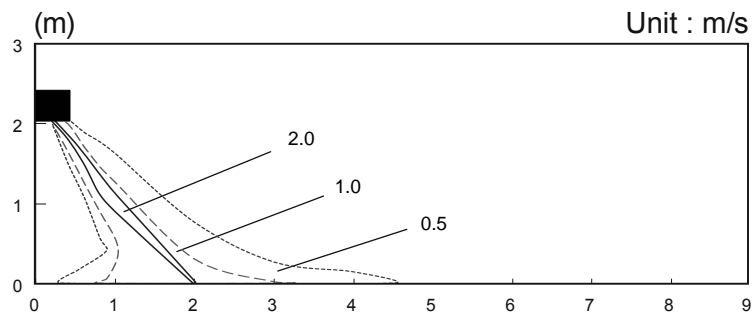

SIDE VIEW  
Vertical airflow direction louver: Down  
Horizontal airflow direction louver: Center

Conditions:  
Fan speed: HIGH  
Operation mode: FAN

**MODEL: AS\*G14LMCB**

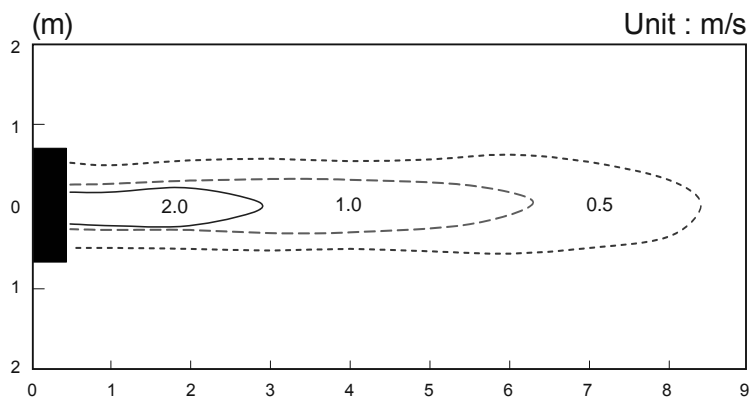

TOP VIEW  
Vertical airflow direction louver: Up  
Horizontal airflow direction louver: Center

(m)

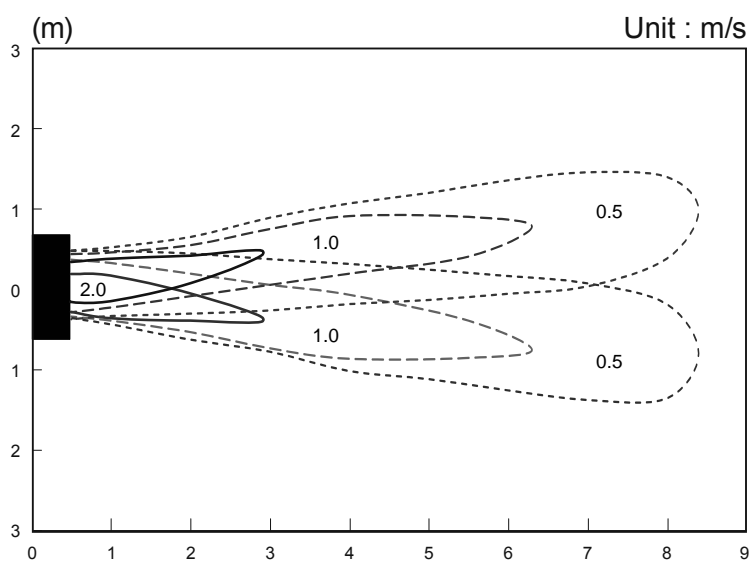

TOP VIEW  
Vertical airflow direction louver: Up  
Horizontal airflow direction louver: Right & Left

(m)

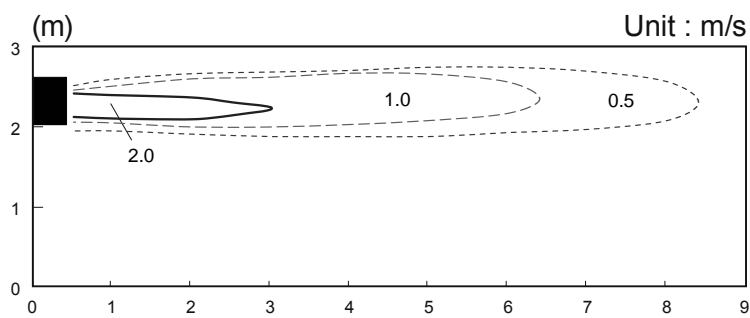

SIDE VIEW  
Vertical airflow direction louver: Up  
Horizontal airflow direction louver: Center

(m)

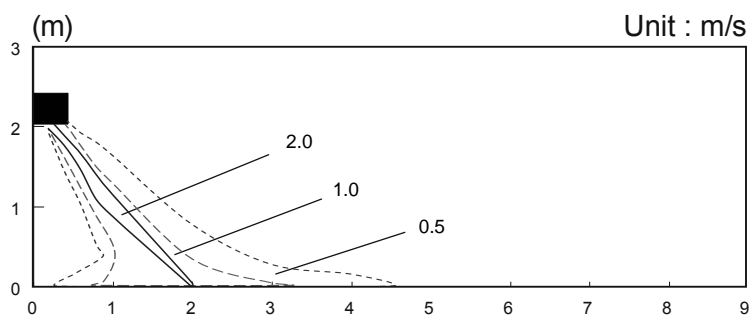

SIDE VIEW  
Vertical airflow direction louver: Down  
Horizontal airflow direction louver: Center

(m)



## 7-2. AIRFLOW

### ■ MODELS : AS\*G09LMCB, AS\*G12LMCB

#### ● Cooling

Fan speed	Number of rotations (r.p.m.)	Airflow	
HIGH	1320	m <sup>3</sup> /h	750
		l/s	208
		CFM	441
MED	1160	m <sup>3</sup> /h	640
		l/s	178
		CFM	376
LOW	930	m <sup>3</sup> /h	480
		l/s	133
		CFM	282
QUIET	680	m <sup>3</sup> /h	310
		l/s	86
		CFM	182

#### ● Heating

Fan speed	Number of rotations (r.p.m.)	Airflow	
HIGH	1320	m <sup>3</sup> /h	750
		l/s	208
		CFM	441
MED	1160	m <sup>3</sup> /h	640
		l/s	178
		CFM	376
LOW	980	m <sup>3</sup> /h	520
		l/s	144
		CFM	306
QUIET	710	m <sup>3</sup> /h	330
		l/s	92
		CFM	194

## ■ MODEL: AS\*G14LMCB

### ● Cooling

Fan speed	Number of rotations (r.p.m.)	Airflow	
		m <sup>3</sup> /h	l/s
HIGH	1360	770	213
		453	128
		CFM	150
MED	1220	680	188
		400	112
		CFM	127
LOW	990	530	147
		311	87
		CFM	100
QUIET	750	360	100
		212	60
		CFM	73

### ● Heating

Fan speed	Number of rotations (r.p.m.)	Airflow	
		m <sup>3</sup> /h	l/s
HIGH	1360	770	213
		453	128
		CFM	150
MED	1220	680	188
		400	112
		CFM	127
LOW	1040	560	155
		329	93
		CFM	117
QUIET	770	380	105
		223	63
		CFM	79

# 8. OPERATION NOISE (SOUND PRESSURE)

## 8-1. NOISE LEVEL CURVE

### MODEL: AS\*G09LMCB

#### ● Cooling

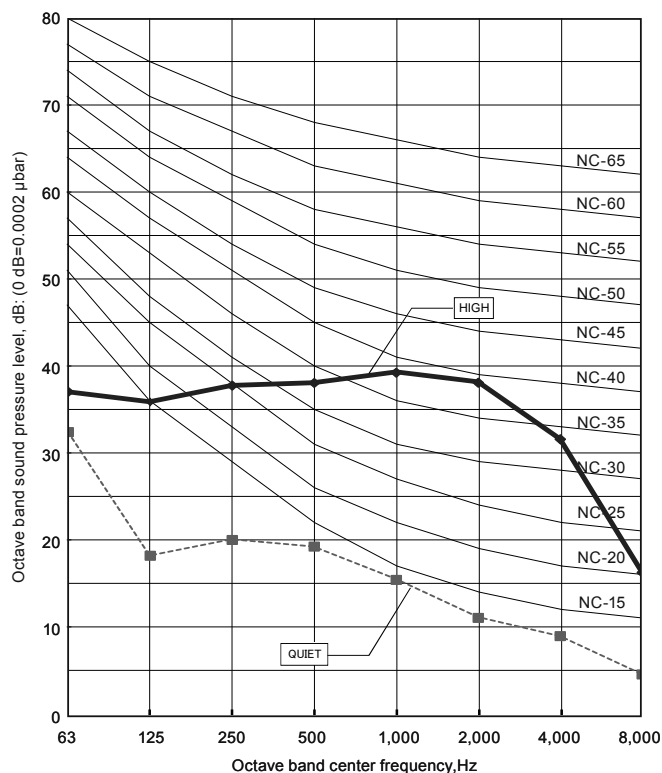

#### ● Heating

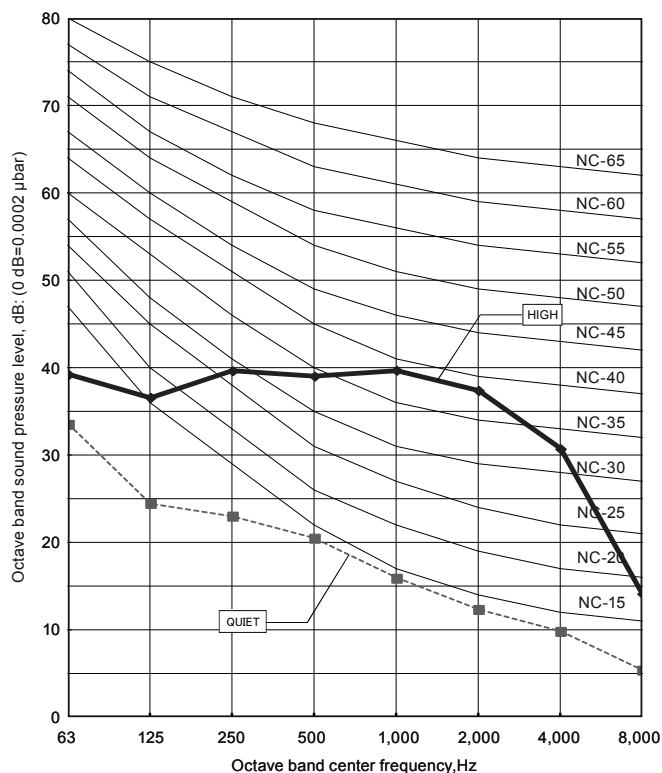

### MODEL: AS\*G12LMCB

#### ● Cooling

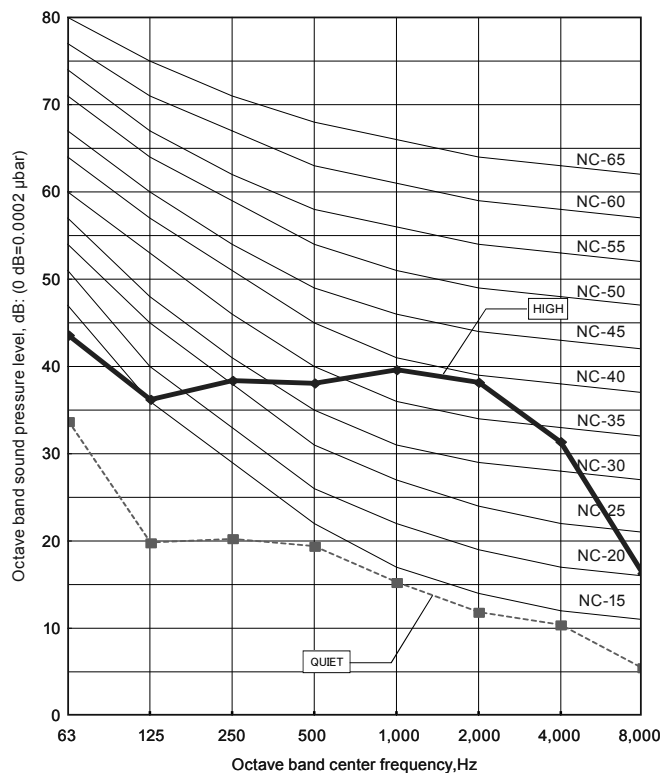

#### ● Heating

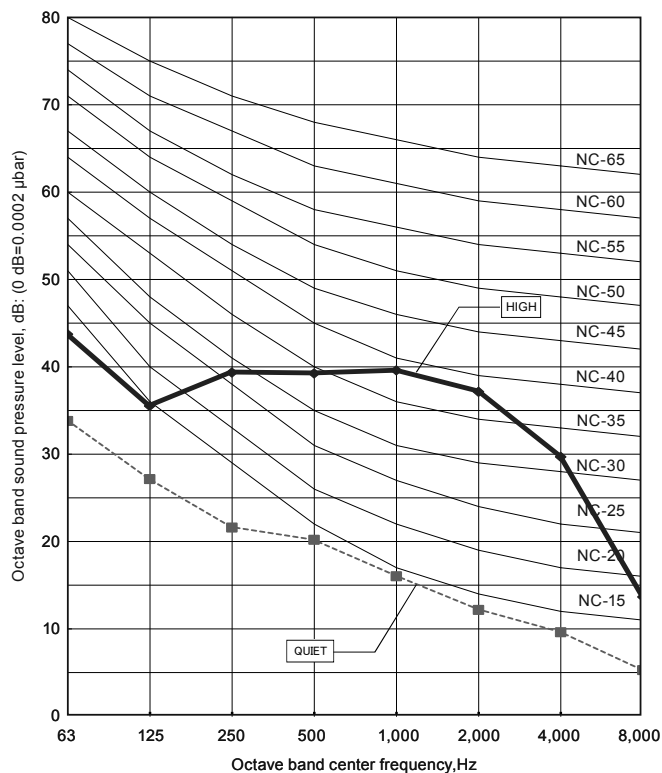

# MODEL: AS\*G14LMCB

## ● Cooling

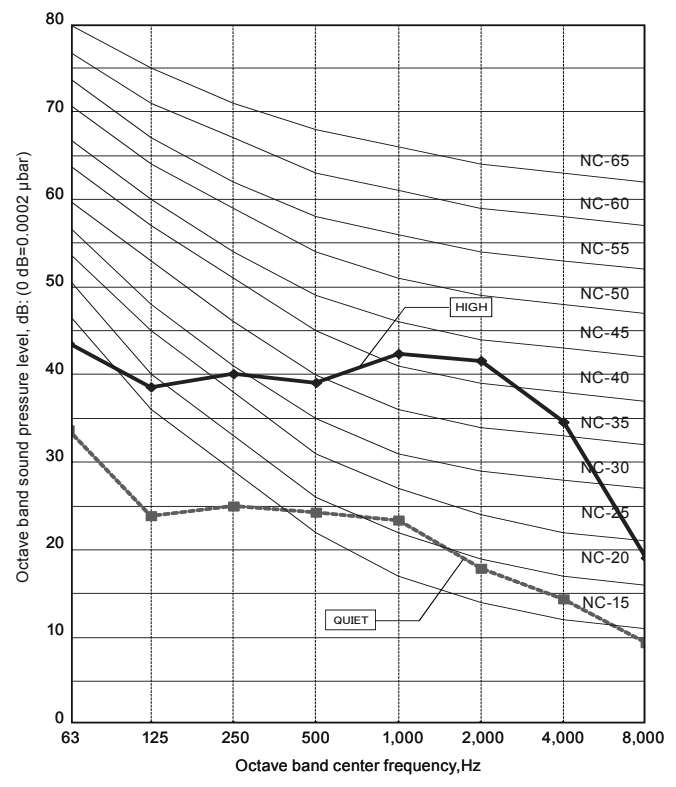

## ● Heating

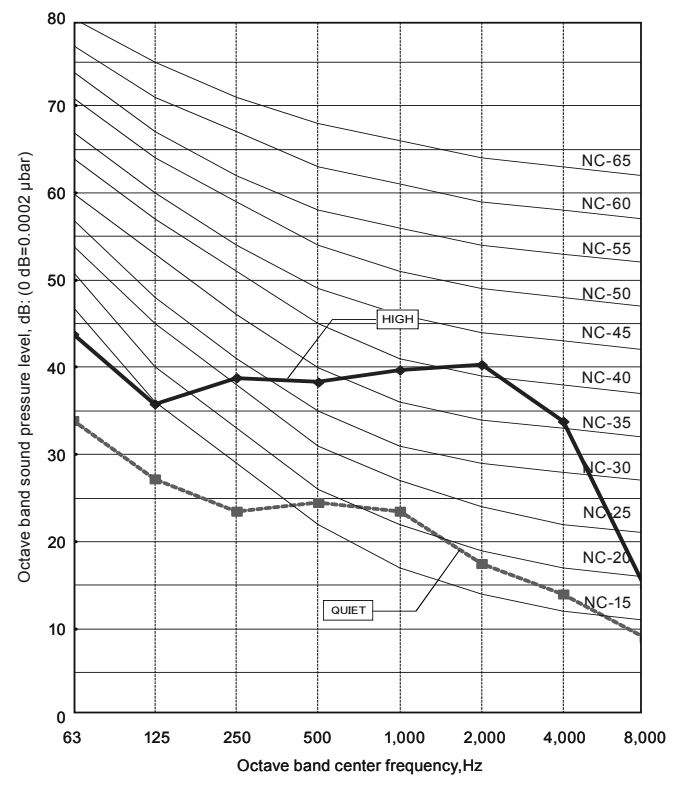

## 8-2. SOUND LEVEL CHECK POINT

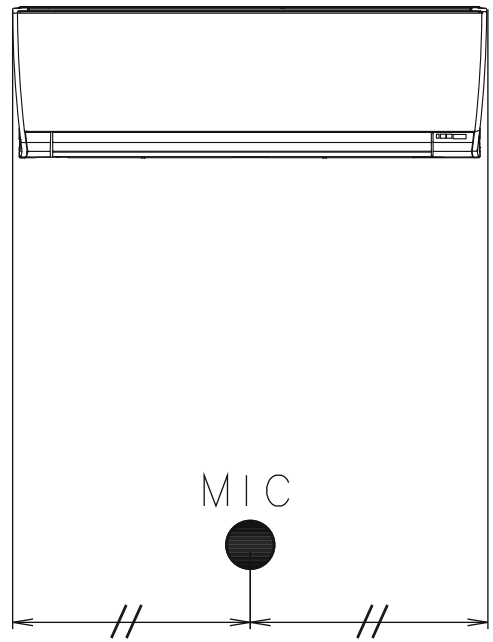
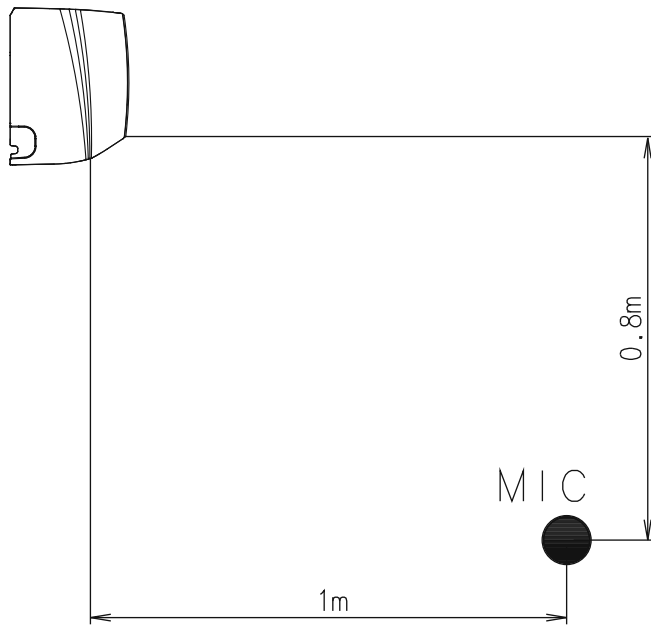

## 9. ELECTRICAL CHARACTERISTICS

Model name			AS*G09LMCB	AS*G12LMCB	AS*G14LMCB
Power supply	Voltage	V	230~		
	Frequency	Hz	50		
Max. operating current		A	0.4		
Wiring spec.	Connection cable	mm <sup>2</sup>	1.5		
	Limited wiring length	m	21		

Note : Wiring Spec.

1. Selected Sample

(Selected based on Japan Electrotechnical Standards and Codes Committee E0005)

2. Limited wiring length: Limit voltage drop to less than 2%. Increase cable gauge if voltage drop is 2% or more.

## 10. SAFETY DEVICES

	Protection form	Model
		AS*G09LMCB AS*G12LMCB AS*G14LMCB
Circuit protection	Current fuse (PC board)	250V 3.15A
Fan motor protection	Thermal protector program	OFF: $105 \pm 10$ °C ON: $90 \pm 10$ °C

# 11. EXTERNAL INPUT & OUTPUT

Connector	INPUT	OUTPUT	REMARKS
CNA01	Control input	-	See external input/output settings for details.
CNB01	-	Operation status output	
CNB02	-	Error status output	

## 11-1. EXTERNAL INPUT

### ■ CONTROL INPUT (Operation/Stop or Forced stop)

The air conditioner can be remotely operated by means of the following on-site work.

"Operation/Stop" mode or "Forced stop" mode can be selected with function setting of indoor unit.

Unit operation is started at the following contents by adding the contact input of a commercial ON/OFF switch to a connector on the external control PC board and turning it ON.

Unit operation	Initial setting after power is ON	Starting mode other than initial setting
Operation mode	Auto changeover	Mode at previous operation
Set temperature	24°C	Temperature at previous operation
Air flow mode	AUTO	Mode at previous operation
Up-down air direction (swing)	Standard air direction (swing OFF)	Air direction at previous operation

### ● Circuit diagram example

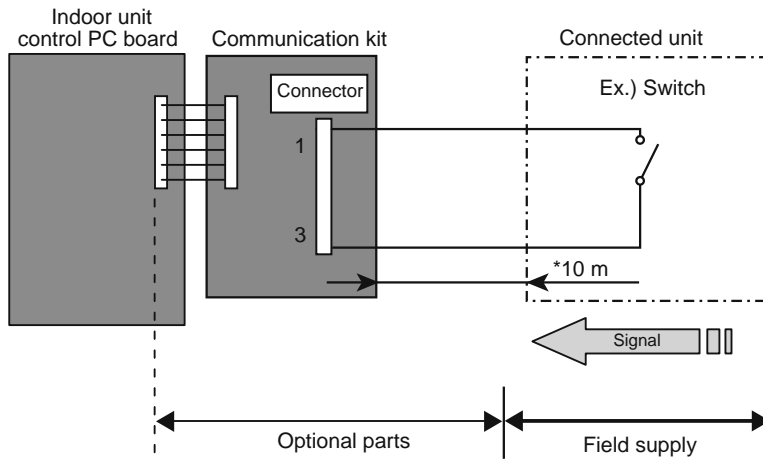

\* Make the distance from the PC board to the connected unit within 10m.  
Contact capacity: DC 24 V or more, 10 mA or more.  
Use non-polar relays and switches.

### ● When function setting is in "Operation/Stop" mode

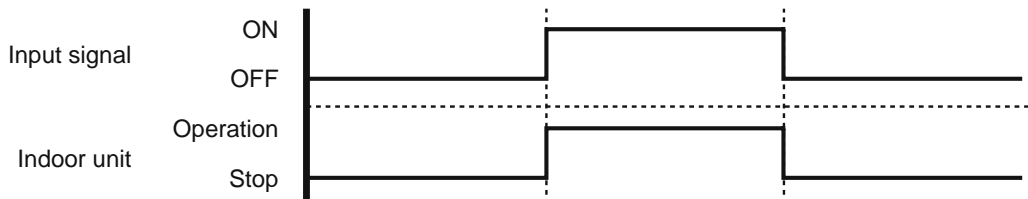



● When function setting is in "Forced stop" mode

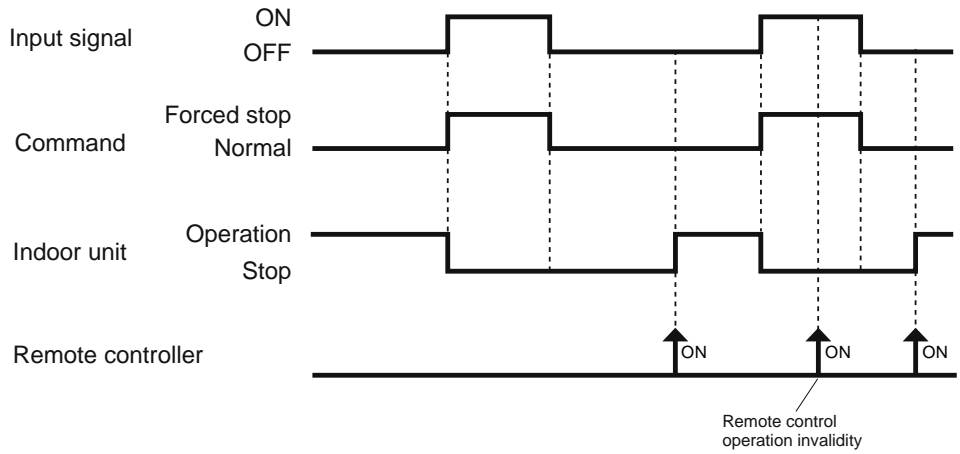

● Parts (Optional)

Parts name	Model name
External connect kit	UTY-XWZXZ5
Communication kit	UTY-XCBXZ2

\*For operating the EXTERNAL function, the wall mounted type requires the communication kit in addition to the wire (UTY-XWZXZ5).

Wire (External input) : UTY-XWZXZ5



# 11-2. EXTERNAL OUTPUT

## ■ OPERATION STATUS OUTPUT

An air conditioner operation status signal can be output.

### ● Circuit diagram example

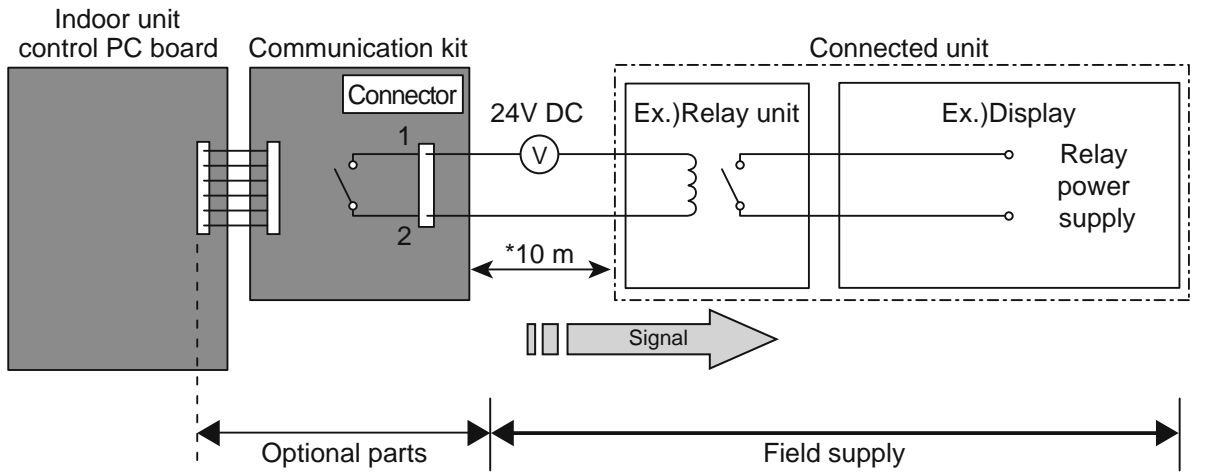

\*: Make the distance from the PC board to the connected unit within 10 m.  
Relay spec.: Max. DC 24 V, 10 mA to less than 500 mA.

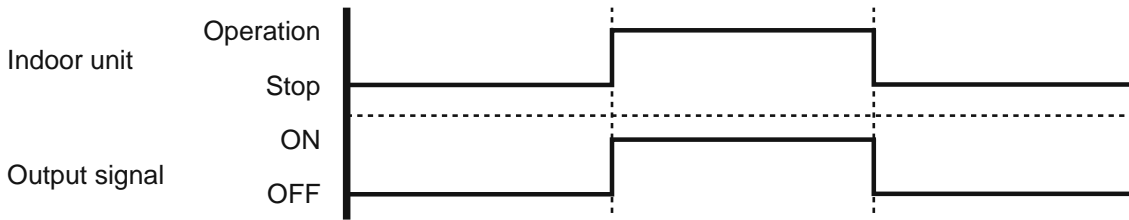

### ● Parts (Optional)

Parts name	Model name
External connect kit	UTY-XWZXZ5
Communication kit	UTY-XCBXZ2

\*For operating the EXTERNAL function, the wall mounted type requires the communication kit in addition to the wire (UTY-XWZXZ5).

Wire (External output) : UTY-XWZXZ5



## ■ ERROR STATUS OUTPUT

An air conditioner error status signal can be output.

### ● Circuit diagram example

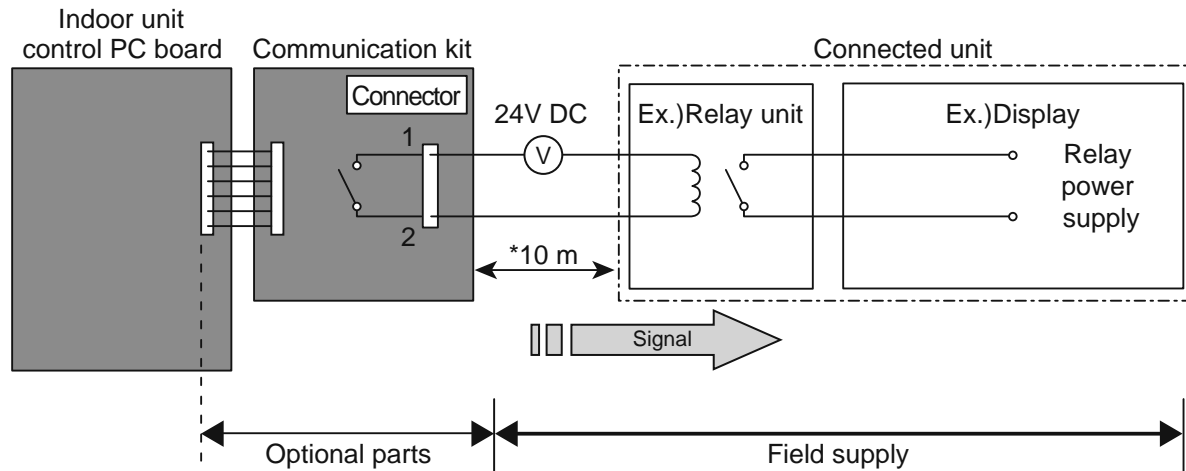

\*: Make the distance from the PC board to the connected unit within 10 m.  
Relay spec.: Max. DC 24 V, 10 mA to less than 500 mA.

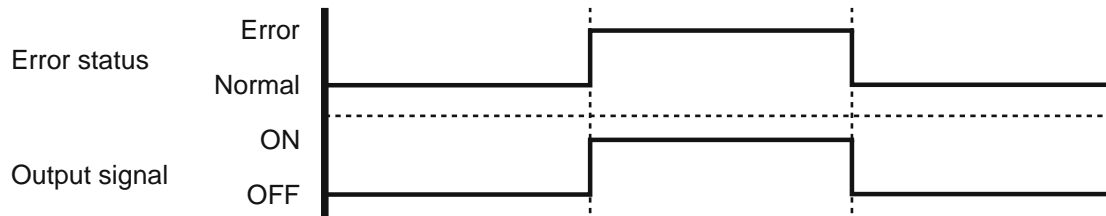

### ● Parts (Optional)

Parts name	Model name
External connect kit	UTY-XWZXZ5
Communication kit	UTY-XCBXZ2

\*For operating the EXTERNAL function, the wall mounted type requires the communication kit in addition to the wire (UTY-XWZXZ5).

Wire (External output) : UTY-XWZXZ5



## 12. FUNCTION SETTINGS

### 12-1. INDOOR UNIT (Setting by remote controller)

- The function settings of the control of the indoor unit can be changed by this procedure according to the installation conditions. Incorrect settings can cause the indoor unit to malfunction.
- After the power is turned on, perform the Function Setting according to the installation conditions using the remote controller.
- The settings may be selected between the following two: Function Number and Setting Value.
- Settings will not be changed if invalid numbers or setting values are selected.

#### ■ PREPARATION

- Before turning on the power of the indoor unit:
  - Confirm whether the piping air-tight test and vacuuming have been conducted.
  - Reconfirm whether there is no miswiring.
- Turn on the power of the indoor units.

#### ■ FUNCTION SETTING METHOD (for Wireless remote controller)

##### Entering the Function Setting Mode

- While pressing the POWERFUL button and SET TEMP. (▲) simultaneously, press the RESET button to enter the function setting mode.

##### STEP 1

##### Setting the Remote controller Custom Code

Use the following steps to select the custom code of the remote controller. (Note that the air conditioner cannot receive a custom code if the air conditioner has not been set for the custom code.) The custom codes that are set through this process are applicable only during the Function Setting process. For details on how to set the custom codes through the normal process, refer to the instructions under "REMOTE CONTROLLER CUSTOM CODE SETTING".

1. Press the SET TEMP. (▲) (▼) button to change the custom code between  $A \rightarrow b \rightarrow c \rightarrow d$ .  
Match the code on the display to the air conditioner custom code. (initially set to  $A$ )  
(If the custom code does not need to be selected, press the 10°C HEAT button and proceed to **STEP 2**.)
2. Press the MODE button and check that the indoor unit can receive signals at the displayed custom code.
3. Press the 10°C HEAT button to accept the custom code, and proceed to **STEP 2**.

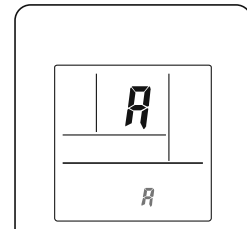

The air conditioner custom code is set to "A" prior to shipment.

The remote controller resets to custom code A when the batteries in the remote controller are replaced. If you use a custom code other than custom code A, reset the custom code after replacing the batteries.  
If you do not know the air conditioner custom code setting, try each of the custom codes ( $A \rightarrow b \rightarrow c \rightarrow d$ ) until you find the code which operates the air conditioner.

##### STEP 2

##### Selecting the Function Number and Setting Value

1. Press the SET TEMP. (▲) (▼) buttons to select the function number.  
(Press the 10°C Heat button to switch between the left and right digits.)
2. Press the POWERFUL button to proceed to setting the value.  
(Press the POWERFUL button again to return to the function number selection.)
3. Press the SET TEMP. (▲) (▼) buttons to select the setting value.  
(Press the 10°C Heat button to switch between the left and right digits.)
4. Press the MODE button, then the START/STOP button in order to fix the settings.
5. Press the RESET button to end the function setting mode.
6. After completing the Function Setting, be sure to turn off the power and turn it on again.

##### Function number

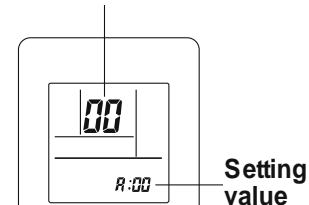

#### ⚠ CAUTION

After turning off the power, wait 30 seconds or more before turning it on again.  
The Function Setting will not become active unless the power is turned off then on again.

## FUNCTION DETAILS

Functions	
1)	Filter sign
2)	Room temperature control for cooling
3)	Room temperature control for heating
4)	Auto restart
5)	Room temperature sensor switching
6)	Remote controller custom code
7)	External input control
8)	Room temperature sensor switching (Aux.)
9)	Indoor unit fan control for energy saving for cooling

### 1) Filter sign

Select appropriate intervals for displaying the filter sign on the indoor unit according to the estimated amount of dust in the air of the room.

If the indication is not required, select "No indication" (03).

(◆... Factory setting)

Setting description	Function number	Setting value
Standard (400 hours)	11	00
Long interval (1000 hours)		01
Short interval (200 hours)		02
No indication		03

### 2) Room temperature control for cooling

Depending on the installed environment, correction of the room temperature sensor may be required.

Select the appropriate control setting according to the installed environment.

(◆... Factory setting)

Setting description	Function number	Setting value
Standard	30	00
Slightly lower control		01
Lower control		02
Higher control		03

### 3) Room temperature control for heating

Depending on the installed environment, correction of the room temperature sensor may be required.

Select the appropriate control setting according to the installed environment.

(◆... Factory setting)

Setting description	Function number	Setting value
Standard	31	00
Lower control		01
Slightly higher control		02
Higher control		03

#### 4) Auto restart

Enable or disable automatic restart after a power interruption.

(◆... Factory setting)

Setting description	Function number	Setting value
◆ Enable	40	00
Disable		01

\*Auto restart is an emergency function such as for power outage etc. Do not attempt to use this function in normal operation. Be sure to operate the unit by remote controller or external input device.

#### 5) Room temperature sensor switching

(Only for wired remote controller)

When using the Wired remote controller temperature sensor, change the setting to "Both" (01).

(◆... Factory setting)

Setting description	Function number	Setting value
◆ Indoor unit	42	00
Both		01

\*00: Sensor on the indoor unit is active.

\*01: Sensors on both indoor unit and wired remote controller is active.

#### 6) Remote controller custom code

(Only for wireless remote controller)

The indoor unit custom code can be changed.

Select the appropriate custom code.

(◆... Factory setting)

Setting description	Function number	Setting value
◆ A	44	00
B		01
C		02
D		03

#### 7) External input control

"Operation/Stop" mode or "Forced stop" mode can be selected.

(◆... Factory setting)

Setting description	Function number	Setting value
◆ Operation/Stop mode	46	00
(Setting prohibited)		01
Forced stop mode		02

#### 8) Room temperature sensor switching (Aux.)

To use the sensor on the wired remote controller only, change the setting to "Wired remote controller" (01). This function will only work if the function setting 42 is set at "Both" (01)

(◆... Factory setting)

Setting description	Function number	Setting value
◆ Both	48	00
Wired remote controller		01

### 9) Indoor unit fan control for energy saving for cooling

Enables or disables the power-saving function by controlling the indoor unit fan rotation when the outdoor unit is stopped during cooling operation.

(◆... Factory setting)

Setting description	Function number	Setting value
Disable	49	00
◆ Enable		01

\*00: When the outdoor unit is stopped, the indoor unit fan operates continuously following the setting on the remote controller..

\*01: When the outdoor unit is stopped, the indoor unit fan operates intermittently at a very low speed.

## ■ REMOTE CONTROLLER CUSTOM CODE SETTING

Use the following steps to select the custom code of the remote controller.

(Note that the air conditioner cannot receive a signal if the right custom code has not been set.)

1. Press the START/STOP button until only the clock is displayed on the remote controller display.
2. Press the MODE button for at least five seconds to display the current custom code (initially set to **A**).
3. Press the SET TEMP. (**▲**) (**▼**) button to change the custom code between **A** → **B** → **C** → **D**.  
Match the code on the display to the air conditioner custom code.
4. Press the MODE button again to return to the clock display. The custom code will be changed.

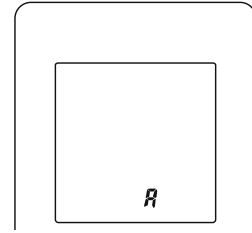

If no buttons are pressed within 30 seconds after the custom code is displayed, the system returns to the original clock display. In this case, start again from step 1.



The air conditioner custom code is set to A prior to shipment.

The remote controller resets to custom code A when the batteries in the remote controller are replaced. If you use a custom code other than custom code A, reset the custom code after replacing the batteries. If you do not know the air conditioner custom code setting, try each of the custom codes (**A** → **B** → **C** → **D**) until you find the code which operates the air conditioner.

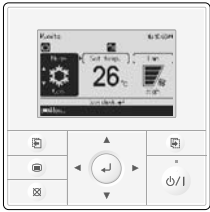

# 13. OPTIONAL PARTS

## 13-1. CONTROLLERS

Exterior	Parts name	Model No.	Summary
	Wired remote controller	UTY-RVN*M	Large and full-dot liquid crystal screen, wide and large keys easy to press, user-intuitive arrow key. *Optional communication kit is necessary for installation.
	Wired remote controller	UTY-RNN*M	The room temperature can be controlled by detecting the temperature accurately with built-in thermo sensor. *Optional communication kit is necessary for installation.
	Simple remote controller	UTY-RSN*M	Compact remote controller concentrates on the basic functions such as Start/Stop, Fan Control, Temperature Setting and Operation mode. *Optional communication kit is necessary for installation.

## 13-2. OTHERS

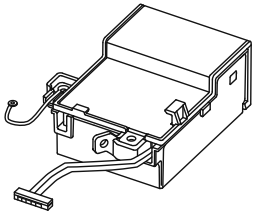
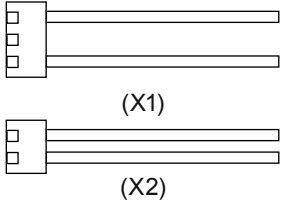
Exterior	Parts name	Model No.	Summary
	Communication kit	UTY-XCBXZ2	Use to connect with optional devices and air conditioner PC board.
	External connect kit	UTY-XWZXZ5	Required when external device is connected. *Optional communication kit is necessary for installation.

## **2. OUTDOOR UNIT**

---

**SINGLE TYPE :**

**AO\*G09LMCBN**

**AO\*G12LMCBN**

**AO\*G14LMCBN**

# CONTENTS

---

## 2. OUTDOOR UNIT

---

1. SPECIFICATIONS.....	02 - 01
2. DIMENSIONS .....	02 - 02
3. REFRIGERANT CIRCUIT .....	02 - 04
4. WIRING DIAGRAMS.....	02 - 06
5. CAPACITY COMPENSATION RATE FOR PIPE LENGTH AND HEIGHT DIFFERENCE .....	02 - 07
6. ADDITIONAL CHARGE CALCULATION.....	02 - 10
7. AIRFLOW .....	02 - 11
8. OPERATION NOISE (SOUND PRESSURE).....	02 - 13
8-1. NOISE LEVEL CURVE .....	02 - 13
8-2. SOUND LEVEL CHECK POINT .....	02 - 15
9. ELECTRIC CHARACTERISTICS.....	02 - 16
10. SAFETY DEVICES .....	02 - 17

# 1. SPECIFICATIONS

OUTDOOR UNIT  
AO\*G09-14LMCBN

OUTDOOR UNIT  
AO\*G09-14LMCBN

Type			INVERTER HEAT PUMP		
Model name			AO*G09LMCBN	AO*G12LMCBN	AO*G14LMCBN
Power source			230V ~ 50Hz		
Available voltage range			198-264V ~ 50Hz		
Starting current		A	3.7	4.7	7.1
Fan	Airflow rate	Cooling	2,020	1,950	2,050
		Heating	1,760	1,700	2,000
	Type×Q'ty	Propeller fan×1			
Motor output		W	37		49
Sound power level	Cooling	dB(A)	63	65	65
	Heating		63	65	65
Sound pressure level	Cooling	dB(A)	48	49	49
	Heating		47	48	49
Heat exchanger type	Dimensions(H×W×D)	mm	508 × 896 × 22	504 × 896 × 18.2	588 × 881 × 36.4
	Fin pitch		1.3		
	Rows×Stages		1 × 20	2 × 24	2 × 28
	Pipe type	Copper			
Fin Type		Aluminium			
Compressor	Type×Q'ty	Rotary ×1			
	Motor output	W	750		850
Refrigerant	Type (Global Warming Potential)	R410A (1975)			
	Charge	g	1,000	1,050	1,200
Refrigerant oil	Type	POE(VG74)			
	Material	Steel			
Enclosure	Colour	Beige			
	Approximate colour of MUNSELL 10YR7.5/1.0				
Dimensions (H×W×D)	Net	mm	540 × 790 × 290		620 × 790 × 290
	Gross		633 × 945 × 395		713 × 945 × 395
Weight	Net	kg	36	39	40
	Gross		40	43	44
Connention pipe	Size	Liquid	Ø6.35 (Ø1/4 in.)		
		Gas	Ø9.52 (Ø3/8 in.)		Ø12.70 (Ø1/2 in.)
	Method	Flare			
	Pre-charge length	m	15		
	Max. length		20		
Max. height difference	15				
Operation range	Cooling	°C	10 to 43		
	Heating		-25 to 24		

**Note :**

Specifications are based on the following conditions.

Cooling : Indoor temperature of 27 °CDB / 19 °CWB.and outdoor temperature of 35 °CDB/24 °CWB.

Heating : Indoor temperature of 20 °CDB / 15 °CWB.and outdoor temperature of 7 °CDB/6 °CWB.

Pipe length : 5 m, Height difference : 0 m.(Outdoor unit - Indoor unit)

The protective function may work when using it outside the operation range.



# MODEL: AO\*G14LMCBN

(Unit : mm)

OUTDOOR UNIT  
AO\*G09-14LMCBN

OUTDOOR UNIT  
AO\*G09-14LMCBN

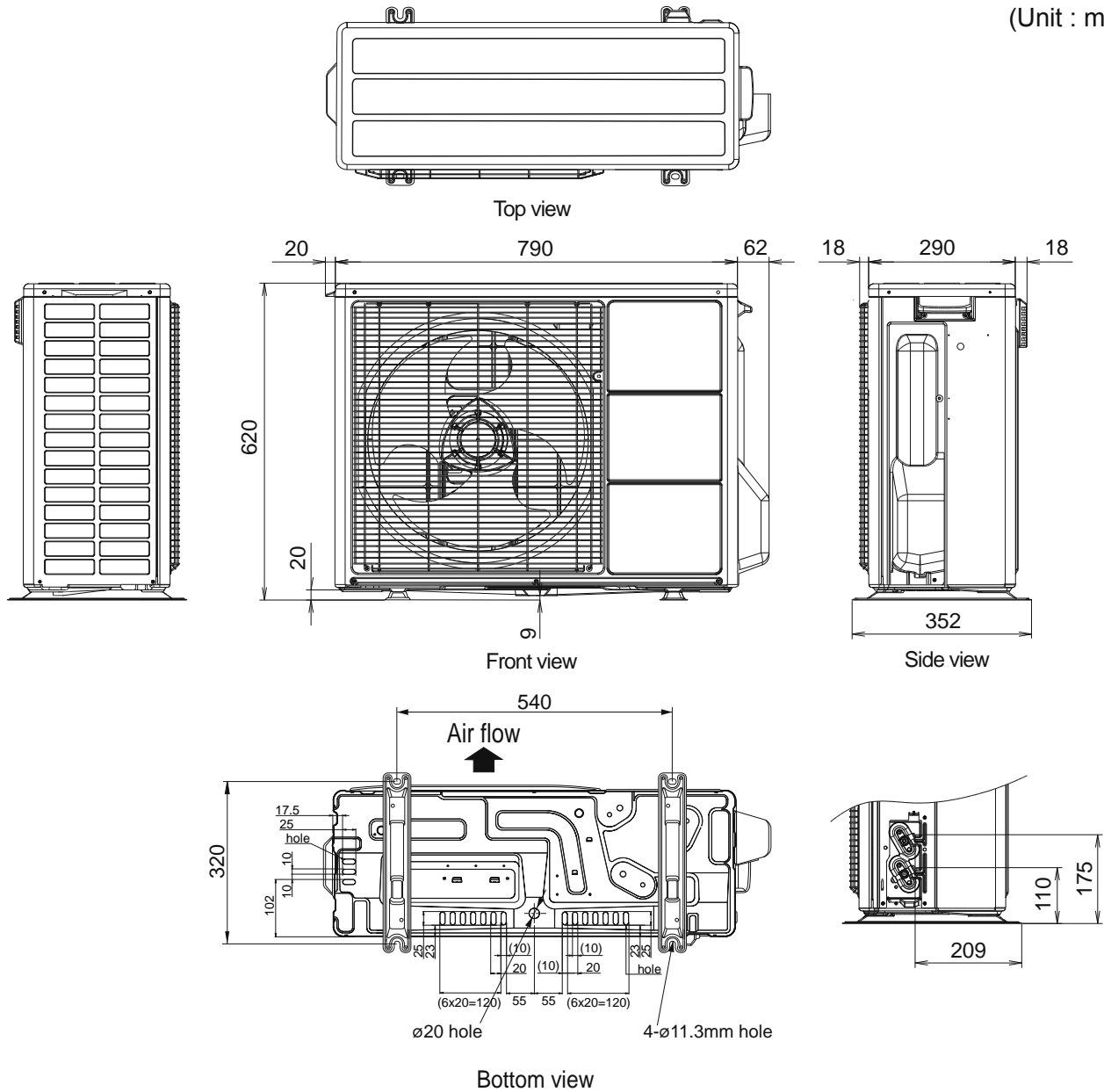

## INSTALLATION PLACE

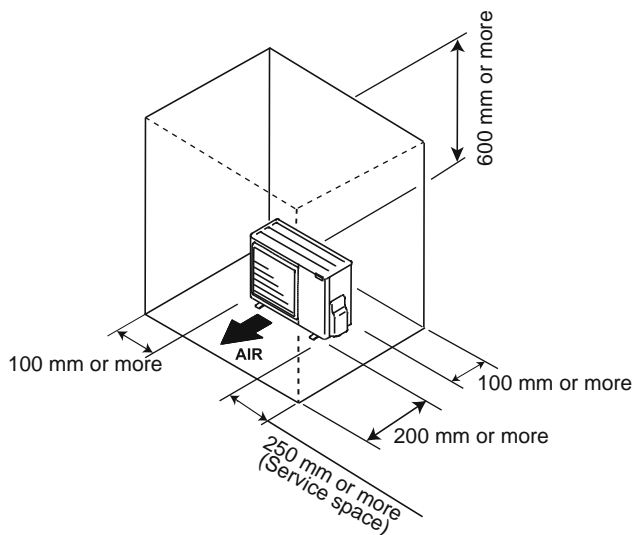

**CAUTION**

In areas with heavy snowfall, if the intake and outlet of the outdoor unit is blocked with snow, it may be difficult to warm up and likely to cause breakdown. In such condition, be sure to construct a canopy or baffle board stand.

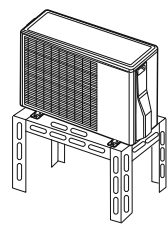

If the space is larger than stated, the condition will be the same as those without any obstacles.

### 3. REFRIGERANT CIRCUIT

■ MODEL: AO\*G09LMCBN, AO\*G12LMCBN

OUTDOOR UNIT  
AO\*G09-14LMCBN

OUTDOOR UNIT  
AO\*G09-14LMCBN

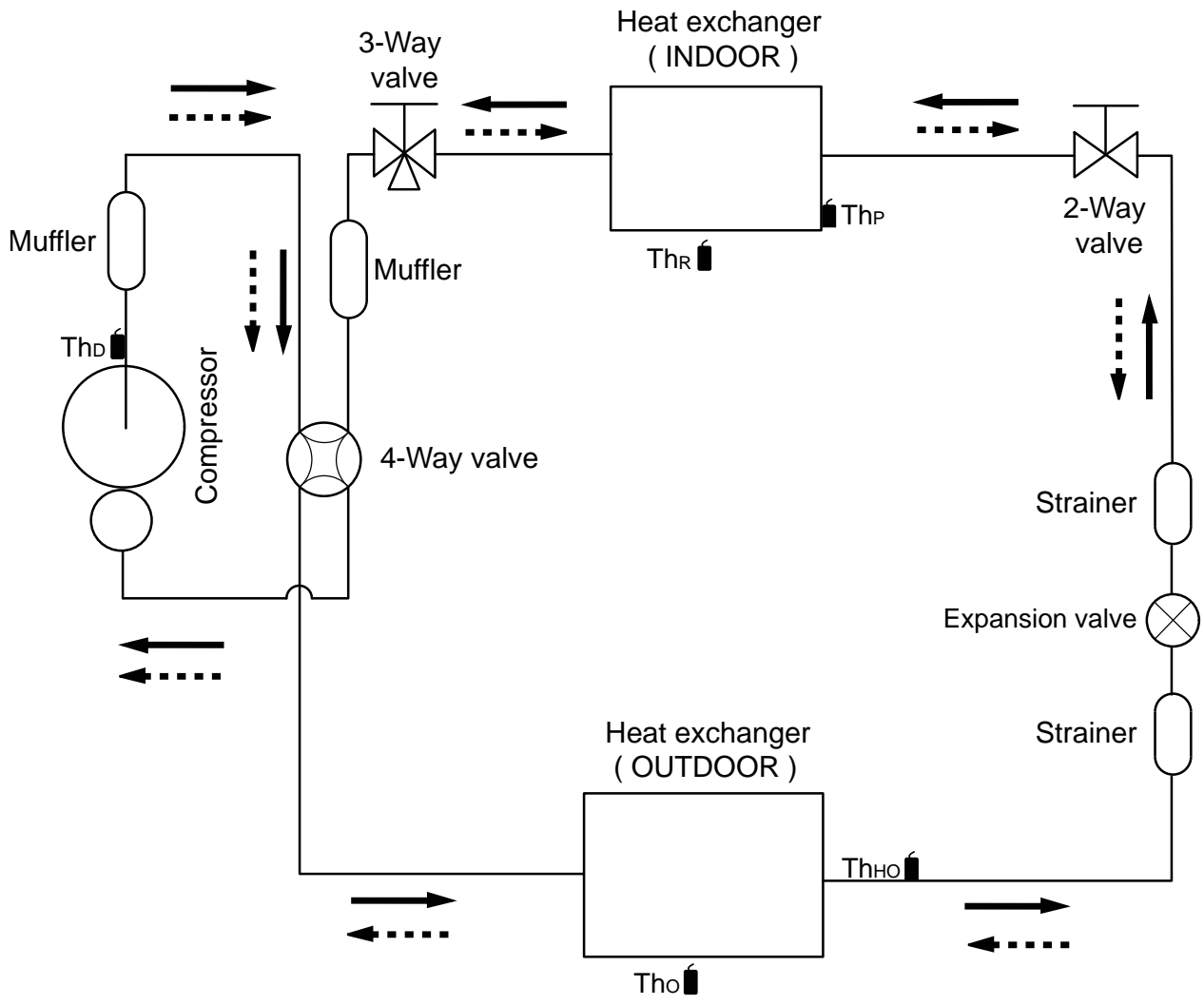

Cooling  
 Heating

- Th<sub>D</sub> : Thermistor (Discharge Temp.)
- Th<sub>O</sub> : Thermistor (Outdoor Temp.)
- Th<sub>HO</sub> : Thermistor (Heat Exchanger Out Temp.)
- Th<sub>R</sub> : Thermistor (Room Temp.)
- Th<sub>P</sub> : Thermistor (Pipe Temp.)

Refrigerant pipe diameter  
 Liquid : 1/4" (6.35 mm)  
 Gas : 3/8" (9.52 mm)

■ MODEL: AO\*G14LMCBN

OUTDOOR UNIT  
AO\*G09-14LMCBN

OUTDOOR UNIT  
AO\*G09-14LMCBN

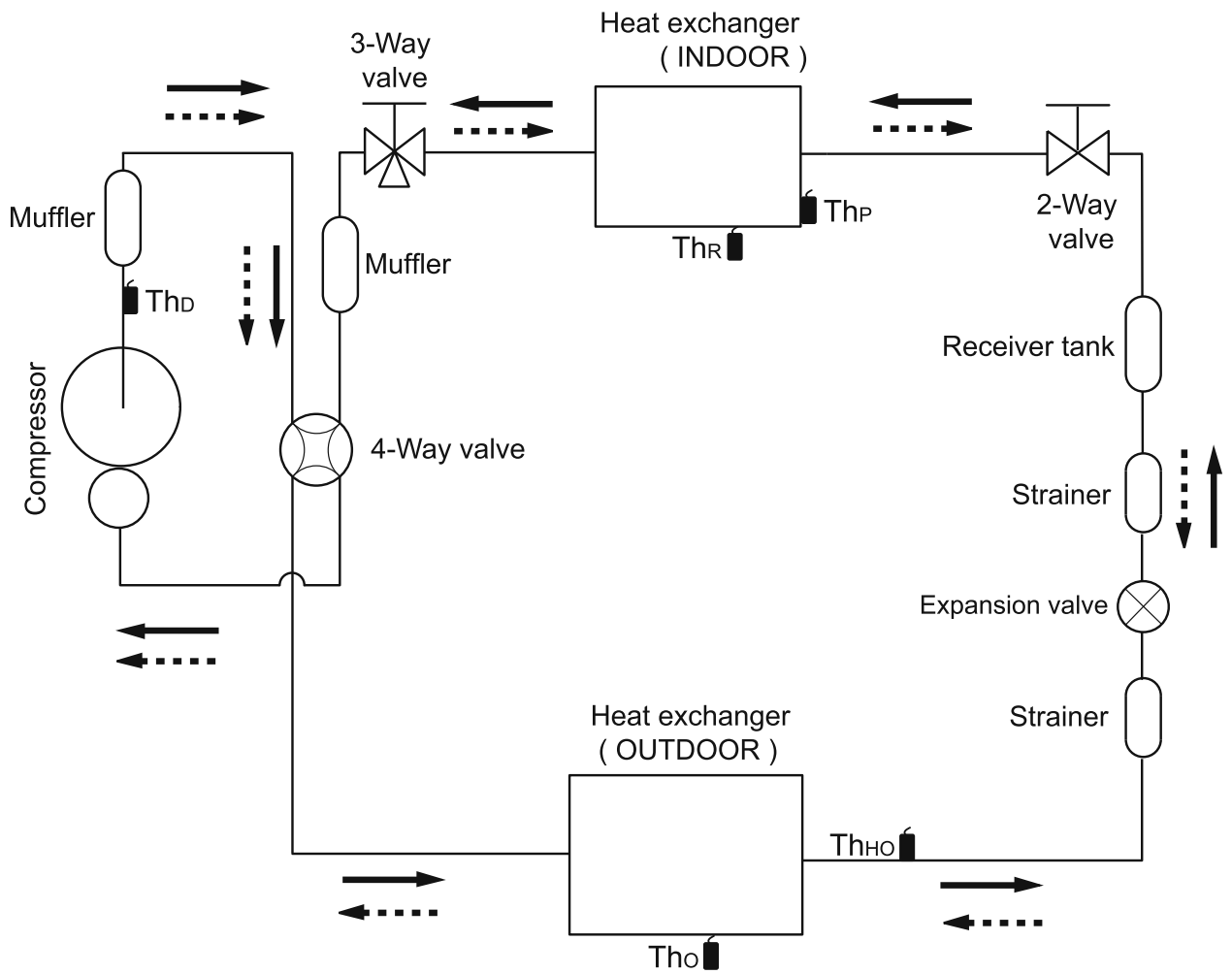

—————> Cooling  
 .....> Heating

- Th<sub>D</sub> : Thermistor (Discharge Temp.)
- Th<sub>O</sub> : Thermistor (Outdoor Temp.)
- Th<sub>HO</sub> : Thermistor (Heat Exchanger Out Temp.)
- Th<sub>R</sub> : Thermistor (Room Temp.)
- Th<sub>P</sub> : Thermistor (Pipe Temp.)

Refrigerant pipe diameter  
 Liquid : 1/4" (6.35 mm)  
 Gas : 1/2" (12.70 mm)



# 4. WIRING DIAGRAMS

■ MODEL: AO\*G09LMCBN, AO\*G12LMCBN, AO\*G14LMCBN

OUTDOOR UNIT  
AO\*G09-14LMCBN

OUTDOOR UNIT  
AO\*G09-14LMCBN

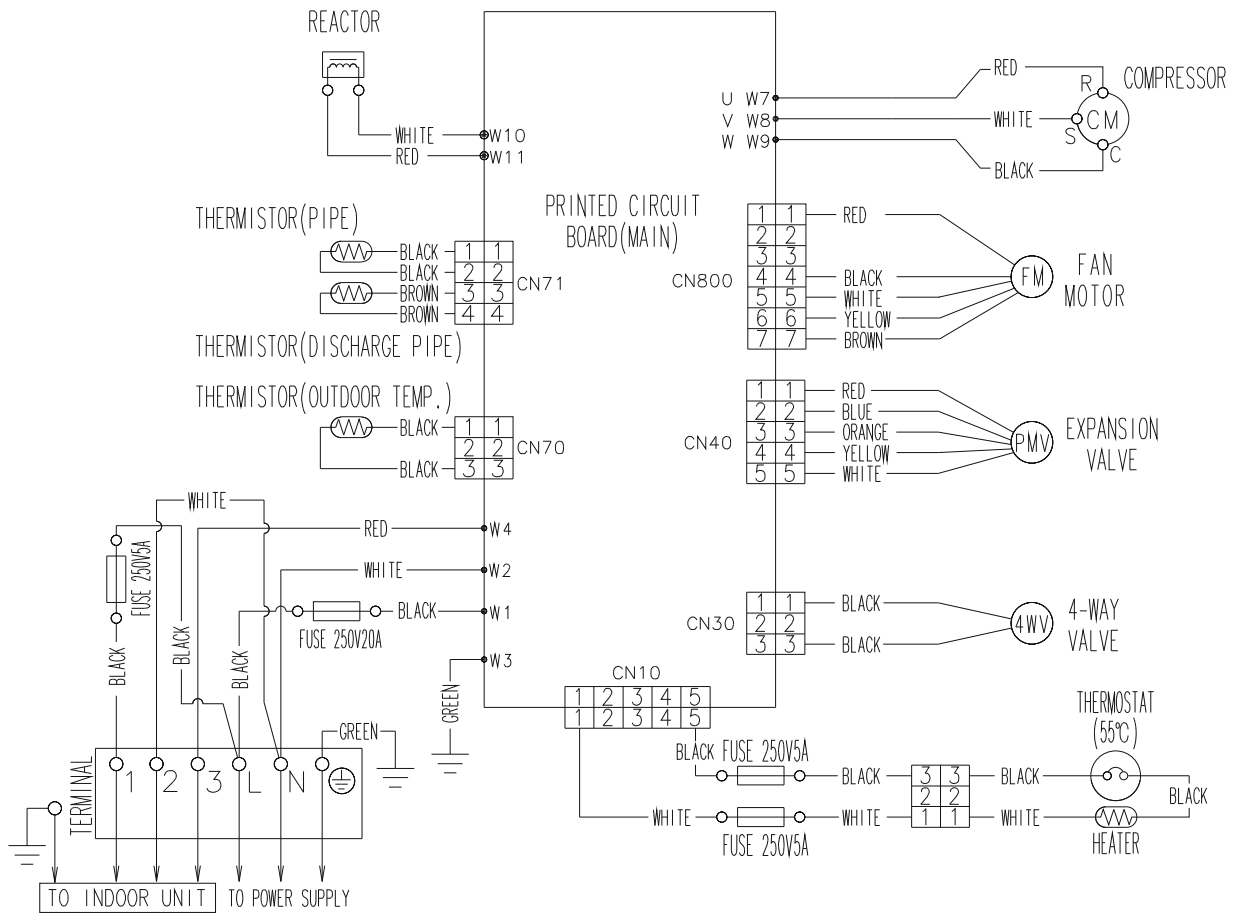

# 5. CAPACITY COMPENSATION RATE FOR PIPE LENGTH AND HEIGHT DIFFERENCE

## MODEL: AO\*G09LMCBN

OUTDOOR UNIT  
AO\*G09-14LMCBN

OUTDOOR UNIT  
AO\*G09-14LMCBN

COOLING			Pipe length (m)				
			5	7.5	10	15	20
Height difference H (m)	*1 Indoor unit is higher than outdoor unit.	15	-	-	-	0.913	0.922
		10	-	-	0.963	0.928	0.937
		7.5	-	0.980	0.967	0.932	0.941
		5	0.992	0.984	0.971	0.936	0.945
		0	1.000	0.992	0.979	0.943	0.953
	*2 Indoor unit is lower than outdoor unit	-5	1.000	0.992	0.979	0.943	0.953
		-7.5	-	0.992	0.979	0.943	0.953
		-10	-	-	0.979	0.943	0.953
		-15	-	-	-	0.943	0.953

HEATING			Pipe length (m)				
			5	7.5	10	15	20
Height difference H (m)	*1 Indoor unit is higher than outdoor unit.	15	-	-	-	0.990	0.969
		10	-	-	1.002	0.990	0.969
		7.5	-	1.001	1.002	0.990	0.969
		5	1.000	1.001	1.002	0.990	0.969
		0	1.000	1.001	1.002	0.990	0.969
	*2 Indoor unit is lower than outdoor unit	-5	0.995	0.996	0.997	0.985	0.964
		-7.5	-	0.994	0.995	0.983	0.962
		-10	-	-	0.992	0.980	0.960
		-15	-	-	-	0.970	0.950

Height difference H

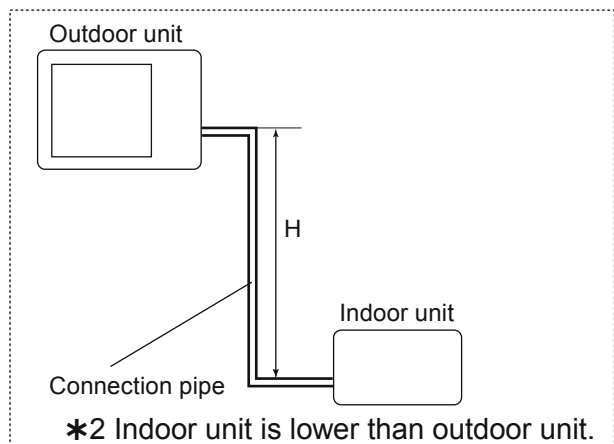
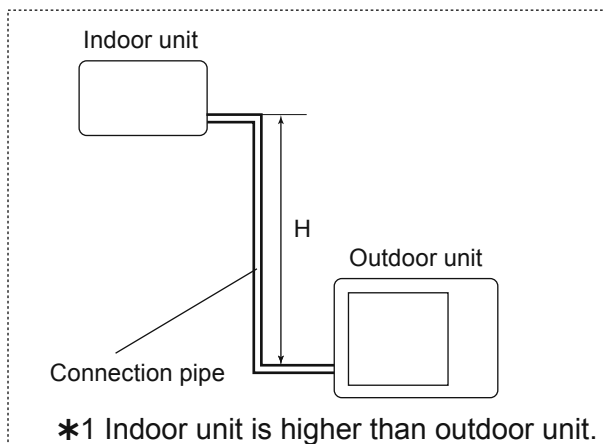

# MODEL: AO\*G12LMCBN

OUTDOOR UNIT  
AO\*G09-14LMCBN

OUTDOOR UNIT  
AO\*G09-14LMCBN

COOLING			Pipe length (m)				
			5	7.5	10	15	20
Height difference H (m)	*1 Indoor unit is higher than outdoor unit.	15	-	-	-	0.882	0.880
		10	-	-	0.943	0.896	0.894
		7.5	-	0.968	0.947	0.900	0.898
		5	0.992	0.972	0.951	0.903	0.901
	0		1.000	0.980	0.958	0.911	0.909
	*2 Indoor unit is lower than outdoor unit	-5	1.000	0.980	0.958	0.911	0.909
		-7.5	-	0.980	0.958	0.911	0.909
		-10	-	-	0.958	0.911	0.909
		-15	-	-	-	0.911	0.909

HEATING			Pipe length (m)				
			5	7.5	10	15	20
Height difference H (m)	*1 Indoor unit is higher than outdoor unit.	15	-	-	-	0.952	0.932
		10	-	-	1.002	0.952	0.932
		7.5	-	1.010	1.002	0.952	0.932
		5	1.000	1.010	1.002	0.952	0.932
	0		1.000	1.010	1.002	0.952	0.932
	*2 Indoor unit is lower than outdoor unit	-5	0.995	1.005	0.997	0.947	0.927
		-7.5	-	1.002	0.994	0.945	0.925
		-10	-	-	0.992	0.942	0.923
		-15	-	-	-	0.933	0.913

### Height difference H

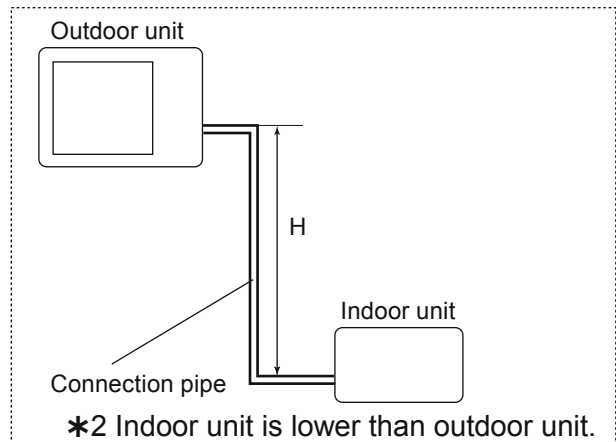
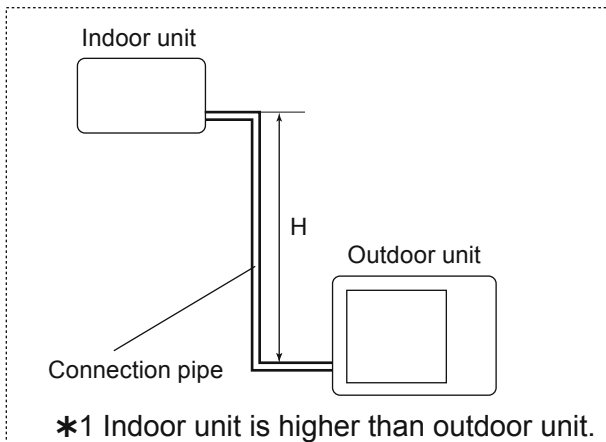

# MODEL: AO\*G14LMCBN

OUTDOOR UNIT  
AO\*G09-14LMCBN

OUTDOOR UNIT  
AO\*G09-14LMCBN

COOLING			Pipe length (m)				
			5	7.5	10	15	20
Height difference H (m)	*1 Indoor unit is higher than outdoor unit.	15	-	-	-	0.893	0.909
		10	-	-	0.955	0.908	0.924
		7.5	-	0.975	0.959	0.912	0.928
		5	0.992	0.979	0.963	0.916	0.931
	0		1.000	0.987	0.970	0.923	0.939
	*2 Indoor unit is lower than outdoor unit	-5	1.000	0.987	0.970	0.923	0.939
		-7.5	-	0.987	0.970	0.923	0.939
		-10	-	-	0.970	0.923	0.939
		-15	-	-	-	0.923	0.939

HEATING			Pipe length (m)				
			5	7.5	10	15	20
Height difference H (m)	*1 Indoor unit is higher than outdoor unit.	15	-	-	-	0.956	0.938
		10	-	-	1.004	0.956	0.938
		7.5	-	1.013	1.004	0.956	0.938
		5	1.000	1.013	1.004	0.956	0.938
	0		1.000	1.013	1.004	0.956	0.938
	*2 Indoor unit is lower than outdoor unit	-5	0.995	1.008	0.999	0.951	0.933
		-7.5	-	1.005	0.997	0.948	0.931
		-10	-	-	0.994	0.946	0.929
		-15	-	-	-	0.937	0.919

## Height difference H

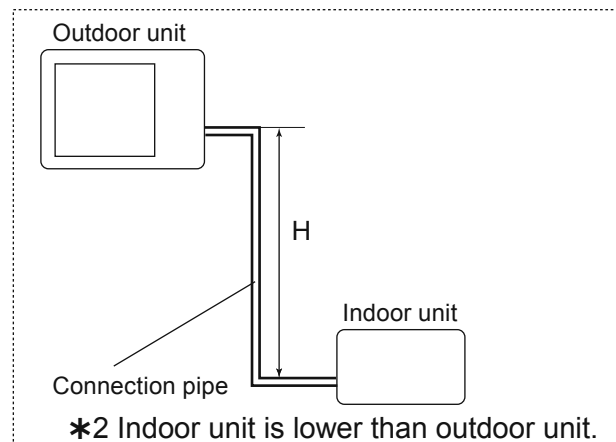
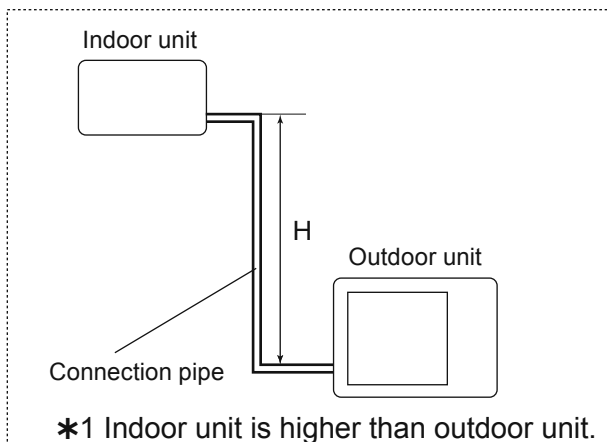

## 6. ADDITIONAL CHARGE CALCULATION

### ■ MODEL: AO\*G09LMCBN

Refrigerant type		R410A
Refrigerant amount	g	1000

#### ● Refrigerant charge

Total pipe length	m	15 or less	20 (MAX)	20g/m
Additional charge	g	0	100	

### ■ MODEL: AO\*G12LMCBN

Refrigerant type		R410A
Refrigerant amount	g	1050

#### ● Refrigerant charge

Total pipe length	m	15 or less	20 (MAX)	20g/m
Additional charge	g	0	100	

### ■ MODEL: AO\*G14LMCBN

Refrigerant type		R410A
Refrigerant amount	g	1200

#### ● Refrigerant charge

Total pipe length	m	15 or less	20 (MAX)	20g/m
Additional charge	g	0	100	

## 7. AIRFLOW

### ■ MODEL: AO\*G09LMCBN

#### ● Cooling

Number of rotations (r.p.m)	Airflow	
850	2020	m <sup>3</sup> /h
	561	l/s
	1189	CFM

#### ● Heating

Number of rotations (r.p.m)	Airflow	
750	1760	m <sup>3</sup> /h
	489	l/s
	1036	CFM

### ■ MODEL: AO\*G12LMCBN

#### ● Cooling

Number of rotations (r.p.m)	Airflow	
850	1950	m <sup>3</sup> /h
	542	l/s
	1148	CFM

#### ● Heating

Number of rotations (r.p.m)	Airflow	
750	1700	m <sup>3</sup> /h
	472	l/s
	1000	CFM

## ■ MODEL: AO\*G14LMCBN

### ● Cooling

Number of rotations (r.p.m.)	Airflow	
	870	2050
569		l/s
1206		CFM

### ● Heating

Number of rotations (r.p.m.)	Airflow	
	780	2000
556		l/s
1176		CFM

# 8. OPERATION NOISE (SOUND PRESSURE)

## 8-1. NOISE LEVEL CURVE

### MODEL: AO\*G09LMCBN

#### ● Cooling

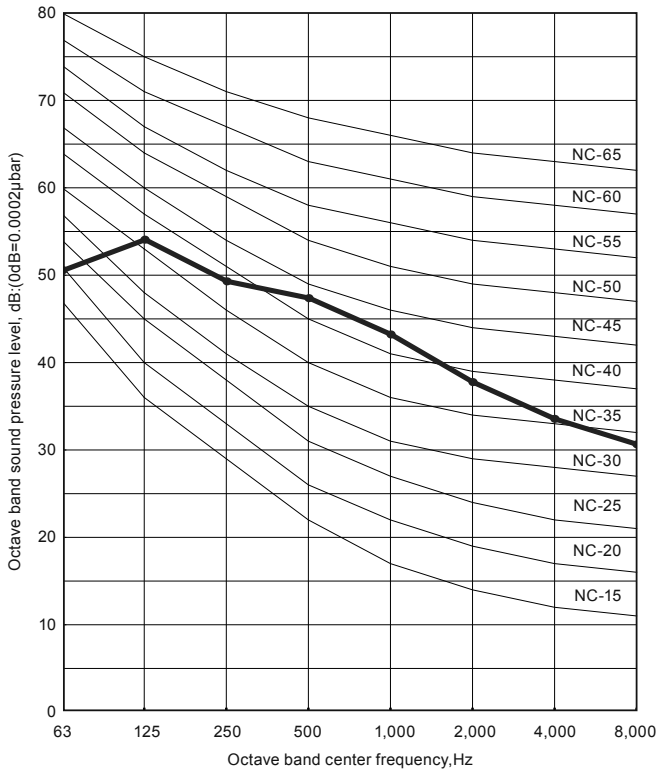

#### ● Heating

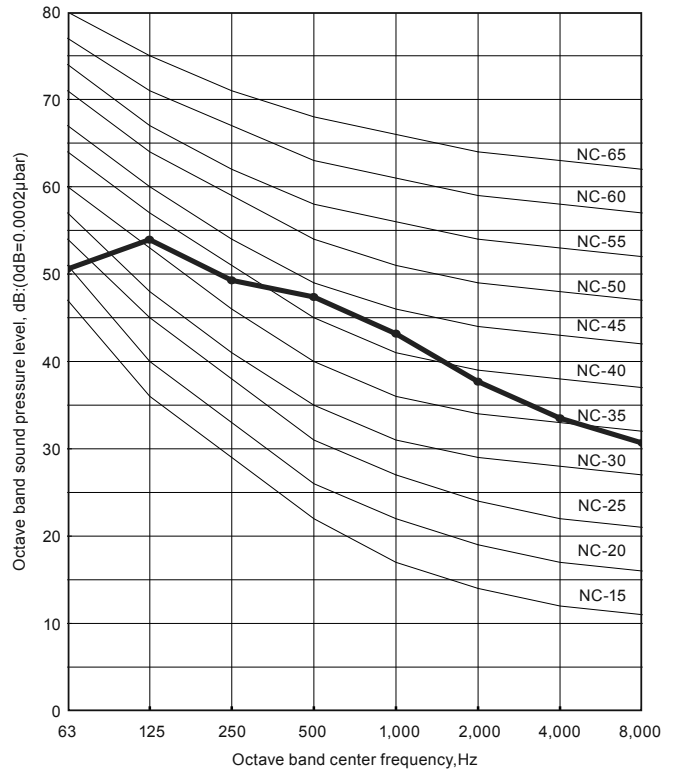

### MODEL: AO\*G12LMCBN

#### ● Cooling

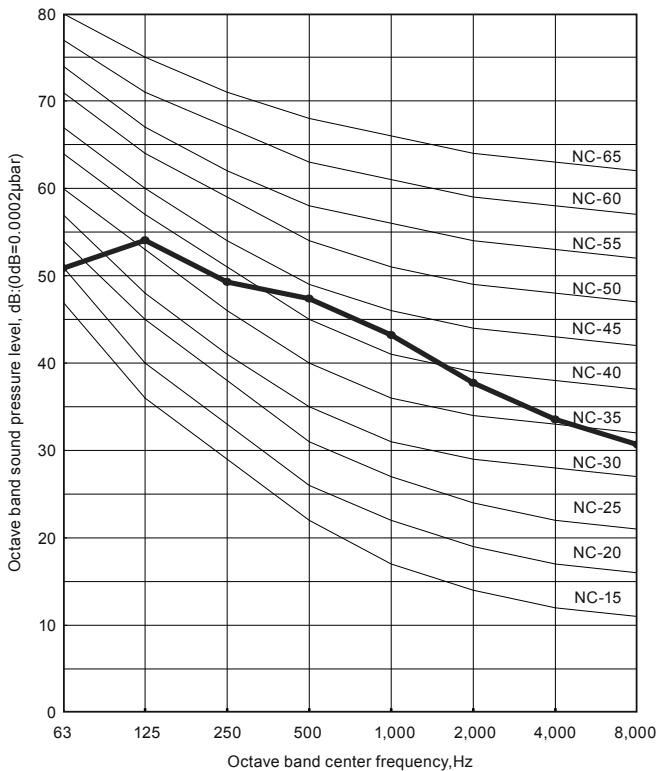

#### ● Heating

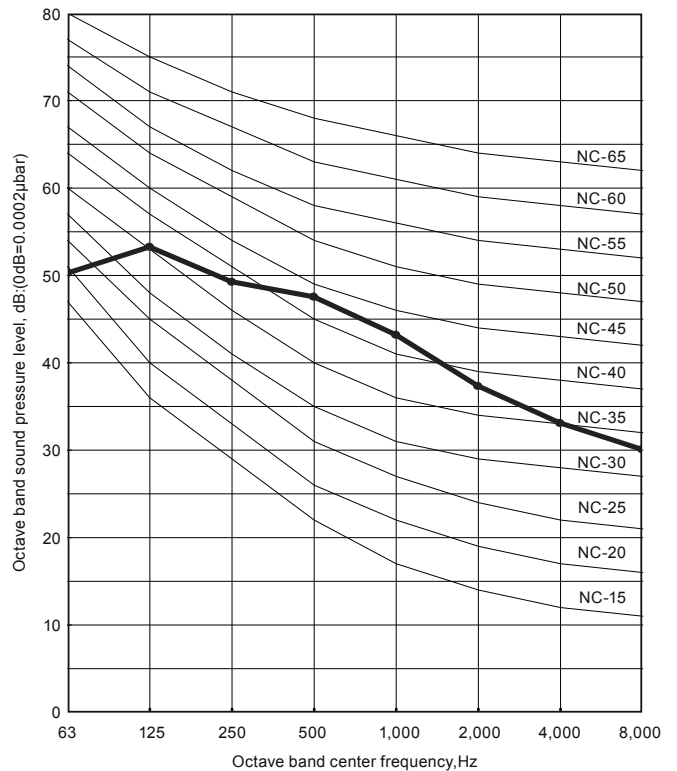

OUTDOOR UNIT  
AO\*G09-14LMCBN

OUTDOOR UNIT  
AO\*G09-14LMCBN



**MODEL: AO\*G14LMCBN**

**● Cooling**

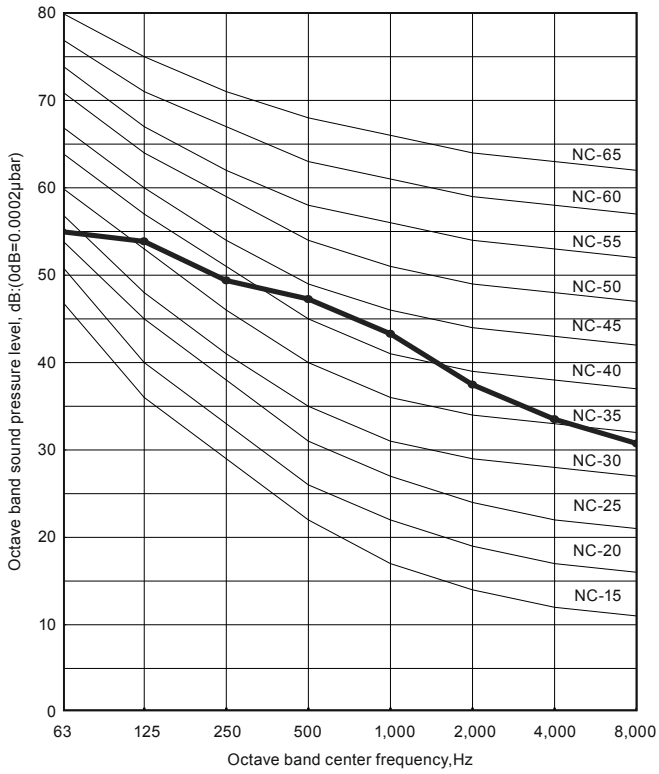

**● Heating**

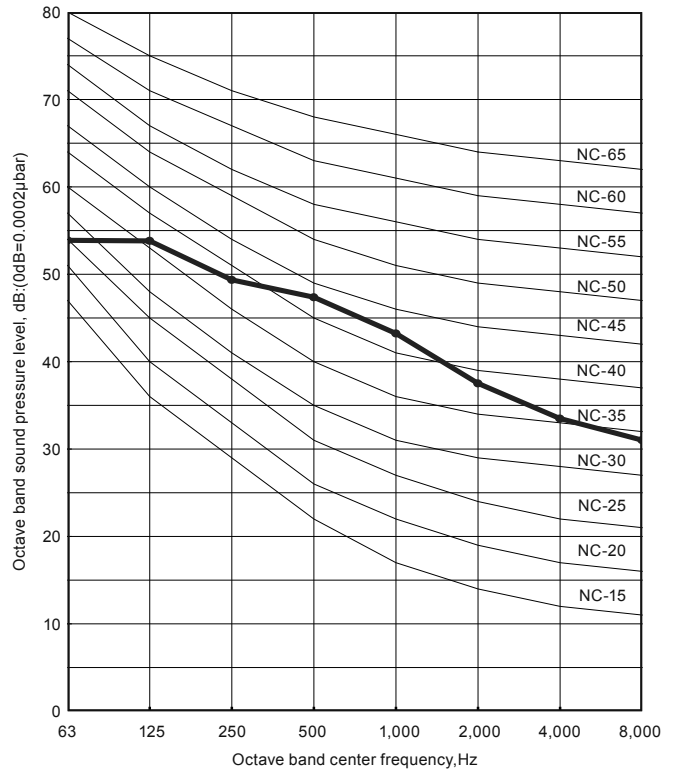

## 8-2. SOUND LEVEL CHECK POINT

OUTDOOR UNIT  
AO\*G09-14LMCBN

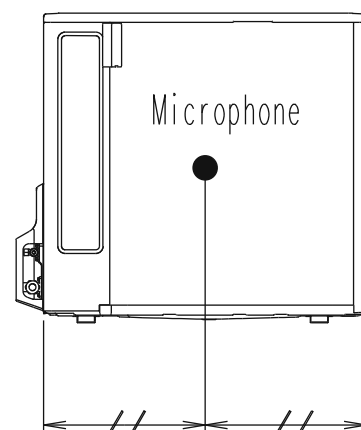
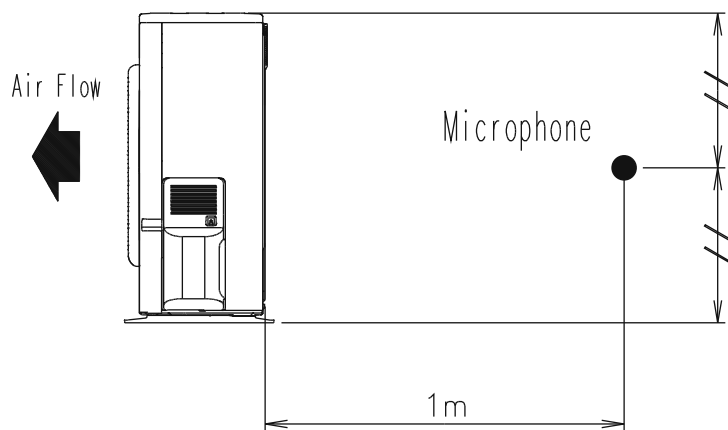

OUTDOOR UNIT  
AO\*G09-14LMCBN

## 9. ELECTRIC CHARACTERISTICS

Model name			AO*G09LMCBN	AO*G12LMCBN	AO*G14LMCBN
Power supply	Voltage	V	230 ~		
	Frequency	Hz	50		
*1) Max operating current		A	9.5	11.0	11.5
Starting Current		A	3.7	4.7	7.1
*2) Wiring spec.	Circuit breaker current	A	15		20
	Power cable	mm <sup>2</sup>	1.5	3.5 - 4.0	

\*1) The maximum current is the total current of indoor unit and outdoor unit.

\*2) Wiring Spec.:

Selected Sample

(Selected based on Japan Electrotechnical Standard and Codes Committee E0005)

# 10. SAFETY DEVICES

OUTDOOR UNIT  
AO\*G09-14LMCBN

OUTDOOR UNIT  
AO\*G09-14LMCBN

	Protection form	Model		
		AO*G09LMCBN	AO*G12LMCBN	AO*G14LMCBN
Circuit protection	Current fuse (Near the terminal)	250V 20A		
		250V 5A		
	Current fuse (Main printed circuit board)	250V 3.15A		
Fan motor protection	Thermal protection program	OFF : 150±15°C ON : 120±15°C		OFF : 100±15°C ON : 95±10°C
Compressor protection	Thermal protection program (Discharge temp.)	OFF : 110°C ON : After 7 minutes		
Heater protection	Current fuse	250V 5A (2pcs)		
	Thermal protection switch (Heater temp.)	OFF: 55 <sup>+3</sup> <sub>-3</sub> °C ON: 45 <sup>+4</sup> <sub>-4</sub> °C		