



# Gas Leakage Detector

Per applicazioni commerciali e industriali

For commercial and industrial applications



**ITA** MANUALE D'USO  
**ENG** USER MANUAL

**LEGGI E CONSERVA  
QUESTE ISTRUZIONI**  
→ **READ AND SAVE  
THESE INSTRUCTIONS** ←



**NO POWER  
& SIGNAL  
CABLES  
TOGETHER**

**READ CAREFULLY IN THE TEXT!**

**Gas Leakage Detector**

+0300047IE - ITA/ENG

Up to date version available on

[www.carel.com](http://www.carel.com)

## GENERAL WARNINGS



CAREL bases the development of its products on decades of experience in HVAC, on continuous investments in technological innovations to products, procedures and strict quality processes with in-circuit and functional testing on 100% of its products, and on the most innovative production technology available on the market. CAREL and its subsidiaries/affiliates nonetheless cannot guarantee that all the aspects of the product and the software included with the product respond to the requirements of the final application, despite the product being developed according to start-of-the-art techniques. The customer (manufacturer, developer or installer of the final equipment) accepts all liability and risk relating to the configuration of the product in order to reach the expected results in relation to the specific final installation and/or equipment. CAREL may, based on specific agreements, act as a consultant for the successful commissioning of the final unit/application, however in no case does it accept liability for the correct operation of the final equipment/system. The CAREL product is a state-of-the-art product, whose operation is specified in the technical documentation supplied with the product or can be downloaded, even prior to purchase, from the website [www.carel.com](http://www.carel.com). Each CAREL product, in relation to its advanced level of technology, requires setup/configuration/programming/commissioning to be able to operate in the best possible way for the specific application. Failure to complete such operations, which are required/indicated in the user manual, may cause the final product to malfunction; CAREL accepts no liability in such cases. Only qualified personnel may install or carry out technical service on the product. The customer must only use the product in the manner described in the documentation relating to the product. In addition to observing any further warnings described in this manual, the following warnings must be heeded for all CAREL products:

- prevent the electronic circuits from getting wet. Rain, humidity and all types of liquids or condensate contain corrosive minerals that may damage the electronic circuits. In any case, the product should be used or stored in environments that comply with the temperature and humidity limits specified in the manual;
- do not install the device in particularly hot environments. Too high temperatures may reduce the life of electronic devices, damage them and deform or melt the plastic parts. In any case, the product should be used or stored in environments that comply with the temperature and humidity limits specified in the manual;
- do not attempt to open the device in any way other than described in the manual.
- do not drop, hit or shake the device, as the internal circuits and mechanisms may be irreparably damaged;
- do not use corrosive chemicals, solvents or aggressive detergents to clean the device;
- do not use the product for applications other than those specified in the technical manual.

All of the above suggestions likewise apply to the controllers, serial cards, programming keys or any other accessory in the CAREL product portfolio. CAREL adopts a policy of continual development. Consequently, CAREL reserves the right to make changes and improvements to any product described in this document without prior warning. The technical specifications shown in the manual may be changed without prior warning. The liability of CAREL in relation to its products is specified in the CAREL general contract conditions, available on the website [www.carel.com](http://www.carel.com) and/or by specific agreements with customers; specifically, to the extent where allowed by applicable legislation, in no case will CAREL, its employees or subsidiaries/affiliates be liable for any lost earnings or sales, losses of data and information, costs of replacement goods or services, damage to things or people, downtime or any direct, indirect, incidental, actual, punitive, exemplary, special or consequential damage of any kind whatsoever, whether contractual, extra-contractual or due to negligence, or any other liabilities deriving from the installation, use or impossibility to use the product, even if CAREL or its subsidiaries/affiliates are warned of the possibility of such damage.

## DISPOSAL

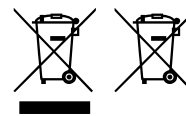

Fig. 1

Fig. 2

### INFORMATION FOR USERS ON THE CORRECT HANDLING OF WASTE ELECTRICAL AND ELECTRONIC EQUIPMENT (WEEE)

The product is made up of metal parts and plastic parts. In reference to European Union directive 2002/96/EC issued on 27 January 2003 and related national legislation, please note that:

- WEEE cannot be disposed of as municipal waste and such waste must be collected and disposed of separately;
- the public or private waste collection systems defined by local legislation must be used. In addition, the equipment can be returned to the distributor at the end of its working life when buying new equipment;
- the equipment may contain hazardous substances: the improper use or incorrect disposal of such may have negative effects on human health and on the environment;
- the symbol (crossed-out wheeled bin) shown on the product or on the packaging and on the technical leaflet indicates that the equipment has been introduced onto the market after 13 August 2005 and that it must be disposed of separately;
- in the event of illegal disposal of electrical and electronic waste, the penalties are specified by local waste disposal legislation.

**Warranty on materials:** 2 years (from production date, excluding consumables).

**Approval:** the quality and safety of CAREL S.p.A. products are guaranteed by the ISO 9001 certified design and production system.



Separate as much as possible the probe and digital input cables from cables to inductive loads and power cables, so as to avoid possible electromagnetic disturbance. Never run power cables (including the electrical panel cables) and signal cables in the same conduits.

#### Key to the symbols:



**Caution:** to bring critical issues to the attention of those using the product.



**Notice:** to focus attention on important topics; in particular the practical application of the various product functions.



**Caution:** this product is to be integrated and/or incorporated into the final apparatus or equipment. Verification of conformity to the laws and technical standards in force in the country where the final apparatus or equipment will be operated is the manufacturer's responsibility. Before delivering the product, Carel has already completed the checks and tests required by the relevant European directives and harmonised standards, using a typical test setup, which however cannot be considered as representing all possible conditions of the final installation.

## HACCP: IMPORTANT



Food Safety programs based on procedures such as HACCP and, more generally, certain national regulations, require that the devices used for food storage be periodically checked to ensure that measurement errors are within the limits allowed for the application used. Carel recommends users to follow, for example, the indications of the European standard "Temperature recorders and thermometers for the transport, storage and distribution of chilled, frozen, deep-frozen/quick-frozen food and ice cream - PERIODIC VERIFICATION", EN 13486 - 2001 (or subsequent updates) or similar regulations and provisions in force in the country in question. Further information can be found in the manual regarding the technical characteristics, correct installation and configuration of the product.



# Index

<b>1. Product descriptions .....</b>	<b>7</b>
1.1 Intended uses / Applications .....	7
2.1 General information.....	9
2.2 Installation tips .....	9
<b>2. Installation .....</b>	<b>9</b>
2.3 Installation.....	10
2.4 Additional installation notes.....	11
<b>3. Operation .....</b>	<b>12</b>
3.1 Power on.....	12
3.2 Device operating states.....	12
3.3 Setting the device using the rotary switch.....	13
3.4 Analogue output .....	15
3.5 Alarm management.....	15
3.6 Magnetic key for configuration .....	16
3.7 RILEVA TE app features .....	17
3.8 Modbus® network.....	20
3.9 Table of Modbus®variables .....	21
<b>4. Maintenance .....</b>	<b>23</b>
4.1 Calibration procedure.....	23
4.2 Calibration kit.....	23
4.3 Calibration via app.....	25
4.4 Calibration via Modbus® communication.....	28
4.5 Sensor replacement procedure.....	30
4.6 Cleaning the device .....	32
<b>5. Further information.....</b>	<b>33</b>
5.1 Sensor operating principle .....	33
5.2 Gas detected .....	34
5.3 Operation of the relays when the instrument is .....	
switched on.....	34
5.4 Relay operating modes.....	34
5.5 Technical specifications .....	37
5.6 Disposal of the device.....	37
5.7 Conformity to standards .....	37
<b>6. Order information.....</b>	<b>38</b>
6.1 Gas Detector GLD Small series part numbers.....	38
6.2 Sensitive element part numbers.....	38
6.3 Accessories .....	38
6.4 Detected gases (semiconductor versions) .....	38
<b>7. Mounting template .....</b>	<b>39</b>



# 1. PRODUCT DESCRIPTIONS

## 1.1 Intended uses / Applications

The GLD Small series leakage detectors continuously monitor the indoor air for any refrigerant leaks. The devices can be used for refrigeration applications (cold rooms, freezer rooms, equipment rooms).

Always check the refrigerant type setting and the warning and alarm thresholds, as described later in this manual.

The GLD series detectors are available in the following configurations:

- GDSB - Built-in version
- GDSR - Remote version

They are calibrated to detect most refrigerants currently available on the market. The sensitive elements are constructed using semiconductor (SC) technology or infrared (IR) technology.

The GLD series detectors can be used in stand-alone applications or connect to Carel controllers or third-party devices. Communication with Carel controllers uses an analogue output, or an RS485 Modbus® serial connection.

When a refrigerant leakage exceeding a certain concentration threshold is detected, an alarm or warning status is activated, depending on the level of concentration set, and the GLD responds as follows:

- The combination of LEDs that are on changes;
- A dedicated internal relay (SPDT) is activated;
- The analogue output is controlled (in proportion to the detected concentration);
- The change in status is signalled via the RS485 Modbus® output and the RILEVA TE application.

Furthermore, the "RILEVA TE" app, available in both App Store and Play Store, can be used to access the device.

The GLD Small series detectors ensure compliance with refrigeration safety standards (EN 378) through visual and audible alarms to alert personnel in the event of a refrigerant leakage.



**WARNING:** semiconductor sensors detect the gas they have been calibrated for, but are also sensitive to other types of gases, solvents, alcohol, or substances containing ammonia, such as cleaning products, present in the environment. This, in certain areas and applications, can lead to false alarms when the substances described above are present. Nonetheless, although they do not only detect the specific gas, they still give a reliable indication of the concentration of the gas they have been calibrated for.



**WARNING:** This device is neither certified nor approved for operation in oxygen-enriched atmospheres. Non-compliance can lead to EXPLOSION.



**WARNING:** This device has not been designed to guarantee intrinsic safety when used in areas classified as hazardous ("Directive 2014/34/EU ATEX" and "NFPA 70, Hazardous Location"). For operator safety, DO NOT use it in hazardous locations (classified as such).

GLD Small is available in five main versions:

- Infrared version for CO<sub>2</sub>
- Electrochemical version for ammonia
- Semiconductor version for R32 refrigerant gas blends
- Semiconductor version for HC refrigerant gases
- Semiconductor version for HFC/HFO refrigerant gases

### 1.1.1 Physical dimensions

Built-in version

Remote version

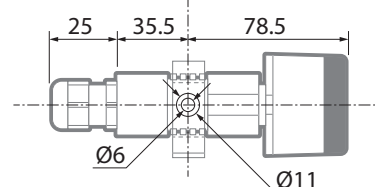
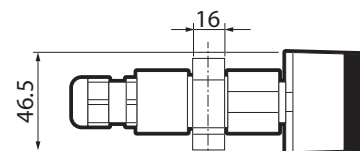
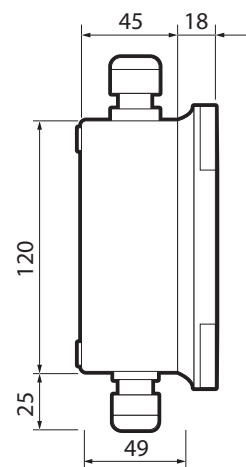
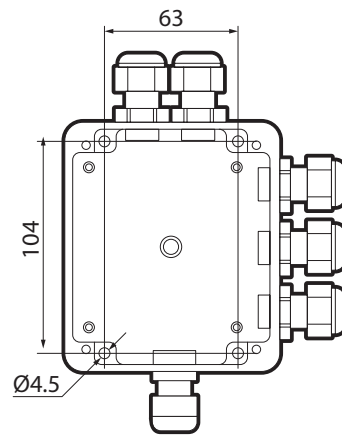
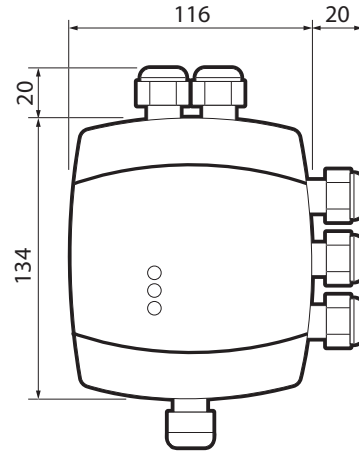
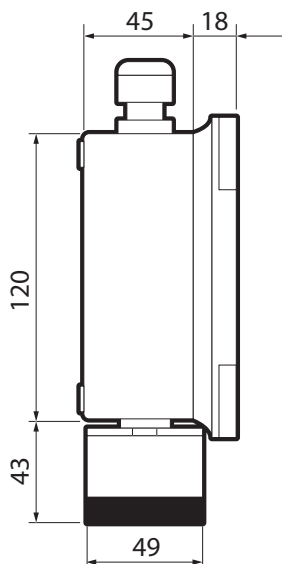
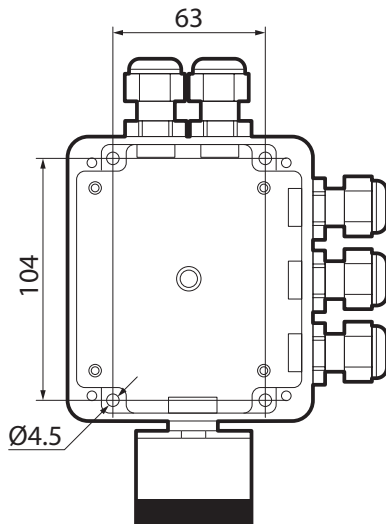
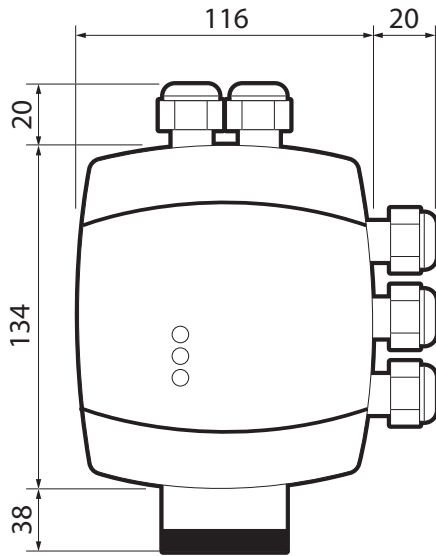

## 2. INSTALLATION



**WARNING:** the gas detector must only be installed by qualified personnel.  
It is recommended to read the manual completely in order to use the product correctly.

### 2.1 General information

The performance and overall effectiveness of the system strictly depend on the characteristics of the place where the gas detector is installed. It is therefore necessary to scrupulously comply with and carefully analyse every detail of the installation process, including (but not limited to) the following aspects:

- local, state and national regulations and standards governing the installation of gas monitoring equipment;
- electrical standards governing the laying and connection of power and signal cables to gas monitoring equipment;
- all possible environmental conditions that the devices will be exposed to;
- the physical characteristics of the gas to be detected (in particular, its specific weight);
- the characteristics of the application (e.g. possible leakages, movement of air, areas where gas may stagnate, high pressure areas, etc.);
- the accessibility needed for routine maintenance and repairs;
- the types of equipment and accessories needed to manage the system;
- any limiting factors or regulations that may affect system performance or installations.



**IMPORTANT:** the installation surfaces must not be exposed to continuous vibrations so as to prevent damage to the connections and electronic devices.

### 2.2 Installation tips



**CAUTION: THERE IS NO GENERAL RULE** for establishing the appropriate number of sensors and their location for each application. Therefore, the guidelines described below are intended as support for installers, and not as rules in their own right. CAREL accepts no liability for the installation of the gas detectors.

#### 2.2.1 Equipment rooms

In equipment rooms, the gas detectors can be installed as follows:

- Position the gas detectors near areas with a high concentration of refrigerant, such as compressors, cylinders, storage tanks, pipes and conduits. Avoid vibrating surfaces.
- Position the gas detectors near mechanical parts such as pressure reducers, valves, flanges, joints (brazed or mechanical) and pipes. In particular, above or below these in relation to the type of gas (see below).
- Position the gas detectors around the perimeter of the room, so as to completely surround the equipment.
- Position the gas detectors in all enclosed areas (stairwells, pits, enclosed corners, etc.) where pockets of stagnant gas may form.
- Position the gas detectors near ventilation air flows, both natural and mechanical (if present).
- Do not place the gas detectors too close to areas with high-pressure gas, to allow this to spread in the space around the gas detector. Otherwise the device may not detect the refrigerant leak if the flow of gas is too fast.

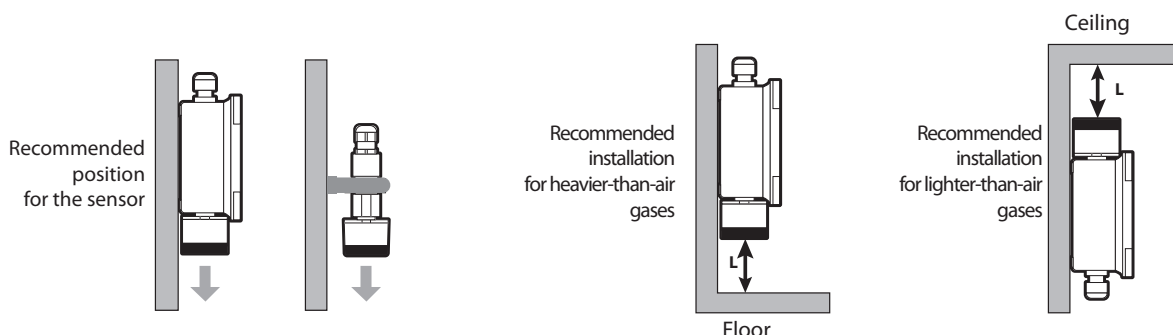

#### 2.2.2 Cold rooms

In cold rooms, position the gas detectors near the return air flow from the evaporator, ideally on a side wall, but not directly in front of the evaporator.

Where there are several evaporators, it may be possible to use one gas detector for every two evaporators, if their positioning allows.

Finally, position the gas detectors near mechanical parts or joints such as valves, flanges and pipes, avoiding areas with high-pressure gas.

### 2.2.3 Chillers

Measuring leaks on outdoor chillers is generally more difficult, given the highly-variable air flow. Generally, it is recommended to install the gas detectors near the compressor, as this is the place where refrigerant leaks are most likely to occur. In particular, check if it is possible to install the gas detector inside the closed unit near the compressor, where gas is more likely to stagnate. However, avoid vibrating surfaces or surfaces that are difficult to access for maintenance. It is also recommended to install gas detectors along the ventilation system, especially in the event of low or variable air flow speeds.

### 2.2.4 Air conditioning - direct VRF/VRV systems

In air conditioned buildings, it is recommended to install at least one gas detector in each room, identifying the areas of greatest risk, such as air flows from ventilation systems and heating systems such as radiators. In these spaces, the refrigerant gas is usually denser than air: consequently, the gas detectors should be installed close to the floor.

Also consider installing the gas detector in ceilings or false ceilings, if not adequately sealed.

Do not install the gas detectors underneath mirrors/washbasins and inside bathrooms.

Do not install the gas detectors near sources of steam.

## 2.3 Installation

Once the optimal position to install the sensor has been chosen, it is recommended to install the sensor (identifiable on the device by the red colour) in a vertical position, with the sensitive element (red part) facing downwards. The sensor can now be mounted on the wall, as follows:

1. Drill the holes in the wall using the template (at the end of the manual) as a reference.
2. Remove the two top and bottom plastic frames, as shown in the figure
3. Fix the device using four screws, chosen according to the type of installation and the type of wall, maximum diameter 4 mm.

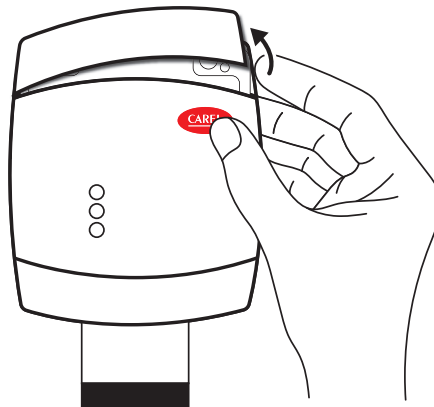

4. Open the cover of the GLD, fit the cable glands and make the required electrical connections. The plug-in terminals can be removed from the device to facilitate wiring.

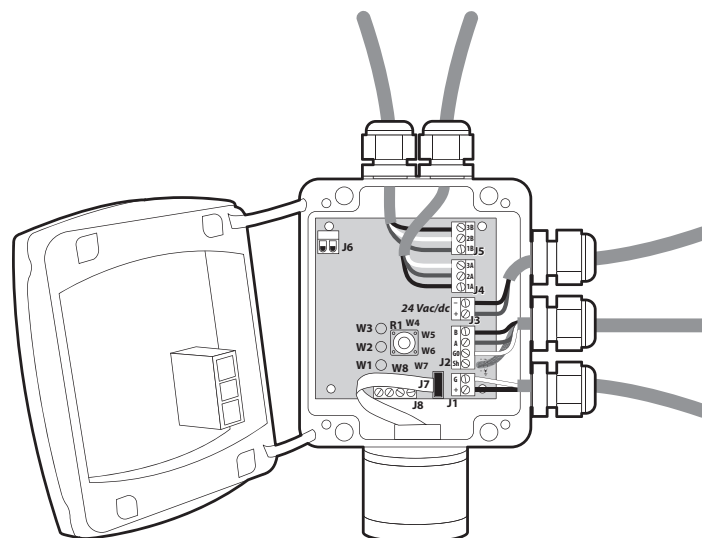

- Power the device on and complete the settings using the rotary switch, as described in the following paragraphs, or using the app, as described below.
- Close the cover. Use the cable glands provided to pass through and connect the cables to the terminals, as shown in the figure and in the connection table below. The terminals can be removed to simplify wiring.

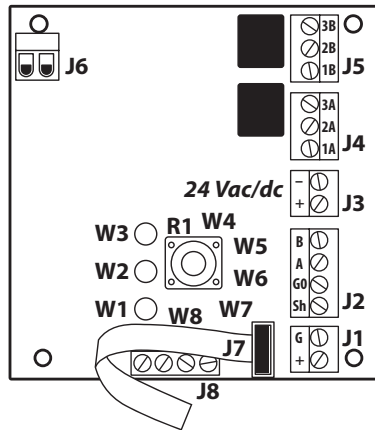

**Electrical connection**

J1	+	Analogue output
	G	Analogue output reference
J2	Sh	Shielded RS485 cable
	G0	GND for RS485
	A	Tx + / Rx + for RS485
	B	Tx - / Rx - for RS485
J3	+24 Vac/dc	For Vac power supply, connect the second transformer wire
	+24 Vdc/dc	For Vdc power supply, connect one of the two power wires, the device automatically recognises whether this is + or GND. For Vac power supply, connect one of the two transformer wires.
J4	1A	NO contact for warning/fault relay
	2A	Common for warning/fault relay
	3A	NC contact for warning/fault relay
J5	1B	NO contact for a alarm relay
	2B	Common for alarm relay
	3B	NC contact for alarm relay
J6	+	V+ for the output voltage provided for service
	G	Service voltage reference
J7	/	Built-in version sensor connector
J8	/	Remote version sensor connector (connection not to be used for built-in products)

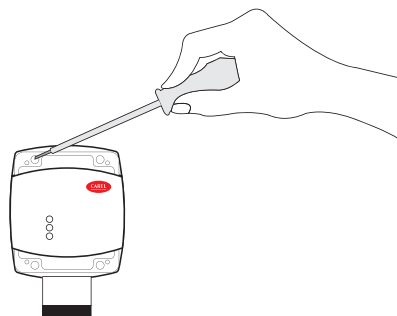

- Secure the detector cover with the four screws.
- Reposition the previously removed plastic frames.
- Power the device on and set the parameters using the "RILEVA TE" app (see the relevant chapter) if the settings were not previously made using the rotary switch.

**2.4 Additional installation notes**

Before commencing electrical installation and wiring, carefully read the following notes.

- Power must be supplied by a safety isolation transformer (Class 2) with no earth connection on the secondary winding.
- The cable for the relays must be sized and fitted with fuses based on the rated voltages, currents and environmental conditions.
- If stranded wires are used, it is recommended to use an end terminal
- To comply with RFI immunity regulations, the communication cable shield on BOSS, mini-BOSS or other supervisors must be earthed (e.g. to the chassis, earth bar, etc.)
- Complete all wiring before powering on.

# 3. OPERATION

## 3.1 Power on

When power is connected, the device begins the start-up cycle, divided into two phases:

- start-up
- warm-up

The start-up sequence lasts around 20 seconds, during which the main functions of the gas detector are initialised and verified. In this phase, the LEDs on the front panel are activated in sequence, and the device cannot yet be used.

At the end of the start-up sequence, the warm-up phase commences, during which the sensor output signal is adjusted and stabilised. In this phase, the device can be used to detect gas and installation can be completed via the rotary switch, app or supervisor; nonetheless, the measurement is less reliable and calibration is not possible.

During the warm-up phase, the green LED flashes around twice every second. The duration of the warm-up phase depends on the sensor technology used:

- Semiconductor = 5 min
- Electrochemical = 5 min
- Infrared = 2 min

The sensors may take longer to warm up than specified; in these cases, do not take any action, wait for the device to stabilise. The time required for complete stabilisation of the device may vary depending on the type of gas and installation.

## 3.2 Device operating states

The CAREL GLD series gas detectors provide visual indications of their current operating status, in addition to the relay outputs. Visual indication of device operating status is provided by three LEDs (green/red/orange).

Device status and the corresponding outputs are shown in the following table:

Relay Warning Fault mode not enabled

Status	LED	Warning/Fault relay	Alarm relay
Warm-up		OFF	OFF
Normal		OFF	OFF
Bluetooth		OFF	OFF
Serial connected	Internal LED W8 on steady	---	---
Warning delay active		OFF	OFF
Alarm delay active		ON	OFF
Warning		ON	OFF
Alarm		ON	ON
Fault		ON	ON

Tab. 3.a

If relay failsafe mode is active, the relay activation logic is reversed.

Device status and corresponding outputs, relay Relay Warning Fault mode enabled

Status	LED	Warning/Fault relay	Alarm relay
Warm-up		OFF	OFF
Normal		OFF	OFF
Bluetooth		OFF	OFF
Serial connected	Internal LED W8 on steady	---	---
Warning delay active		OFF	OFF
Alarm delay active		ON	OFF
Warning		OFF	OFF
Alarm		OFF	ON
Fault		ON	OFF

Tab. 3.b

Key:  
 = LED on steady  
 = LED flashing

### 3.3 Setting the device using the rotary switch

The rotary switch is located inside the device, on the electronic board (R1).

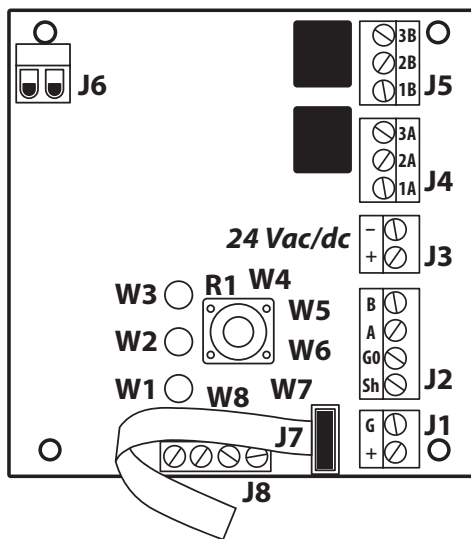

Fig. 3.a

The basic configuration can be performed using the rotary switch, following the instructions described below. To complete the configuration, a digital multimeter is required, with the test leads connected to connector J6. In this way, the tester will show a voltage between 0 and 10 Volts, indicating the value selected by the rotary switch. The meaning of the voltage value displayed changes depending on the selected function: the table below shows the meaning of each voltage for each function.

Setting mode is activated by pressing and holding the rotary switch for 5 seconds. The LED that is ON acts as the menu point, indicating which parameters will be set (all the other LEDs are OFF). Turn the switch to select the parameter to be set. Reading the table, the voltage read with a voltmeter connected to the service terminal indicates the chosen setting.

Pressing the rotary switch for 2 seconds accesses the selected parameter. The corresponding LED flashes.

Turning the rotary switch changes the parameter setting.

After having made the setting, pressing the rotary switch for 5 seconds saves the new value.

Turning the rotary switch again moves to the next parameter.

After two minutes of inactivity or using the magnetic latch, the detector returns to normal operating mode.

#### Description of the rotary switch LEDs

The table below shows the value of the selected parameter and the corresponding voltage value. Each LED corresponds to a different parameter. The default parameter values are saved to permanent memory.

LED W1	Not used
LED W2	Warning level. The operator can set the warning threshold. See the table below for the voltage value corresponding to the selected setting.
LED W3	Alarm level The operator can set the alarm threshold. See the table below for the voltage value corresponding to the selected setting.
LED W4	Modbus address The operator can set the Modbus address. To set the values with greater precision, use the Modbus serial connection or app. See the table below for the voltage value corresponding to the selected setting.
LED W5	Alarm delay The operator can select the delay time for activation of the LED and the alarm relay after the alarm threshold has been exceeded. See the table below for the voltage value corresponding to the selected setting.
LED W6	Type of analogue output voltage. The operator can select the type of analogue output. See the table below for the voltage value corresponding to the selected setting.
LED W7	Alarm/warning reset function mode This parameter is used to select the warning and alarm reset modes. 0 = manual reset (latch) / 1 = automatic reset
LED W8	Modbus configuration The operator can choose the desired Modbus configuration from the options available. See the table below for the voltage value corresponding to the selected setting.

Possible configurations of how to set the warning and alarm relay status in relation to operation of LED W7:

W=0	Manual reset	Manual reset
A=0	Warning	Alarm
W=1	Automatic reset	Manual reset
A=0	Warning	Alarm
W=0	Manual reset	Automatic reset
A=1	Warning	Alarm
W=1	Automatic reset	Automatic reset
A=1	Warning	Alarm

Conversion table voltage value j6 / selected function

Service wheel LED	W2/W3				W4	W5	W6	W7	W8
	Full scale 1000	Full scale 4000	Full scale 10000	Full scale 100					
Voltage [V]	[PPM]	[PPM]	[PPM]	[PPM]	[--]	[m]	[--]	[--]	[--]
0	0	0	0	0	0	0			
0,1	10	100	100	1	1	1			
0,2	20	200	200	2	2	2			
0,3	30	300	300	3	3	3			
0,4	40	400	400	4	4	4			
0,5	50	500	500	5	5	5			
0,6	60	600	600	6	6	6			
0,7	70	700	700	7	7	7			
0,8	80	800	800	8	8	8			
0,9	90	900	900	9	9	9			
1	100	1000	1000	10	10	10			9600 8N1
1,1	110	1100	1100	11	11	11			
1,2	120	1200	1200	12	12	12			
1,3	130	1300	1300	13	13	13			
1,4	140	1400	1400	14	14	14			
1,5	150	1500	1500	15	15	15			
1,6	160	1600	1600	16	16	16			
1,7	170	1700	1700	17	17	17			
1,8	180	1800	1800	18	18	18			
1,9	190	1900	1900	19	19	19			
2	200	2000	2000	20	20	20	4-20 mA	W=0 A=0	9600 8N2
2,1	210	2100	2100	21	21				
2,2	220	2200	2200	22	22				
2,3	230	2300	2300	23	23				
2,4	240	2400	2400	24	24				
2,5	250	2500	2500	25	25				
2,6	260	2600	2600	26	26				
2,7	270	2700	2700	27	27				
2,8	280	2800	2800	28	28				
2,9	290	2900	2900	29	29				
3	300	3000	3000	30	30				19200 8N1
3,1	310	3100	3100	31	31				
3,2	320	3200	3200	32	32				
3,3	330	3300	3300	33	33				
3,4	340	3400	3400	34	34				
3,5	350	3500	3500	35	35				
3,6	360	3600	3600	36	36				
3,7	370	3700	3700	37	37				
3,8	380	3800	3800	38	38				
3,9	390	3900	3900	39	39				
4	400	4000	4000	40	40				19200 8N2
4,1	410		4100	41	41				
4,2	420		4200	42	42				
4,3	430		4300	43	43				
4,4	440		4400	44	44				
4,5	450		4500	45	45				
4,6	460		4600	46	46				
4,7	470		4700	47	47				
4,8	480		4800	48	48				
4,9	490		4900	49	49				
5	500		5000	50	50	1-5 V	W=1 A=0		
5,1	510		5100	51	51				
5,2	520		5200	52	52				
5,3	530		5300	53	53				
5,4	540		5400	54	54				
5,5	550		5500	55	55				
5,6	560		5600	56	56				
5,7	570		5700	57	57				
5,8	580		5800	58	58				
5,9	590		5900	59	59				
6	600		6000	60	60				9600 8E1
6,1	610		6100	61	61				
6,2	620		6200	62	62				
6,3	630		6300	63	63				
6,4	640		6400	64	64				
6,5	650		6500	65	65				

Service wheel LED	W2/W3				W4	W5	W6	W7	W8
	Full scale 1000	Full scale 4000	Full scale 10000	Full scale 100					
Voltage [V]	[PPM]	[PPM]	[PPM]	[PPM]	[--]	[m]	[--]	[--]	[--]
6,6	660		6600	66	66				
6,7	670		6700	67	67				
6,8	680		6800	68	68				
6,9	690		6900	69	69				
7	700		7000	70	70				19200 8E1
7,1	710		7100	71	71				
7,2	720		7200	72	72				
7,3	730		7300	73	73				
7,4	740		7400	74	74				
7,5	750		7500	75	75				
7,6	760		7600	76	76				
7,7	770		7700	77	77				
7,8	780		7800	78	78				
7,9	790		7900	79	79				
8	800		8000	80	80	2-10 V	W=0 A=1	9600 8O1	
8,1	810		8100	81	81				
8,2	820		8200	82	82				
8,3	830		8300	83	83				
8,4	840		8400	84	84				
8,5	850		8500	85	85				
8,6	860		8600	86	86				
8,7	870		8700	87	87				
8,8	880		8800	88	88				
8,9	890		8900	89	89				
9	900		9000	90	90				19200 8O1
9,1	910		9100	91	91				
9,2	920		9200	92	92				
9,3	930		9300	93	93				
9,4	940		9400	94	94				
9,5	950		9500	95	95				
9,6	960		9600	96	96				
9,7	970		9700	97	97				
9,8	980		9800	98	98				
9,9	990		9900	99	99				
10	1000		10000	100	100	0-10 V	W=1 A=1		

### 3.4 Analogue output

The CAREL GLD series gas detectors feature a single configurable analogue output. During normal operation, the device's analogue output signal is proportional to the gas concentration measured, and can be selected from the following options:

- 1 to 5 V
- 2 to 10 V
- 0 to 10 V
- 4 to 20 mA (default)

The CAREL GLD series gas detectors use different voltage/current values to indicate different operating modes. In normal operation, the gas concentration is indicated by the analogue output signal level. The relationship between output signal level and gas concentration is shown below:

Gas concentration	1-5 V	2-10 V	0-10 V	4-20 mA
0%	1 V	2 V	0 V	4 mA
50%	3 V	6 V	5 V	12 mA
100%	5 V	10 V	10 V	20 mA

### 3.5 Alarm management

The alarms are activated when the set thresholds are exceeded. The alarm threshold value must always be greater than the warning value. The alarm and warning thresholds must be less than or equal to the full scale range, and must be greater than or equal to the allowed limit. The alarms are activated when the set thresholds are exceeded.

#### Alarm set points

Sensor, gas and range	Minimum value	Alarm default	Warning default	Maximum value	Unit of measure
GLD group 1 and 2	150	500	150	800	ppm
GLD group 3	400	800	400	3000	ppm
GLD group 4, CO <sub>2</sub>	1000	5000	1500	8000	ppm
GLD group 5, NH <sub>3</sub>	15	30	15	80	ppm

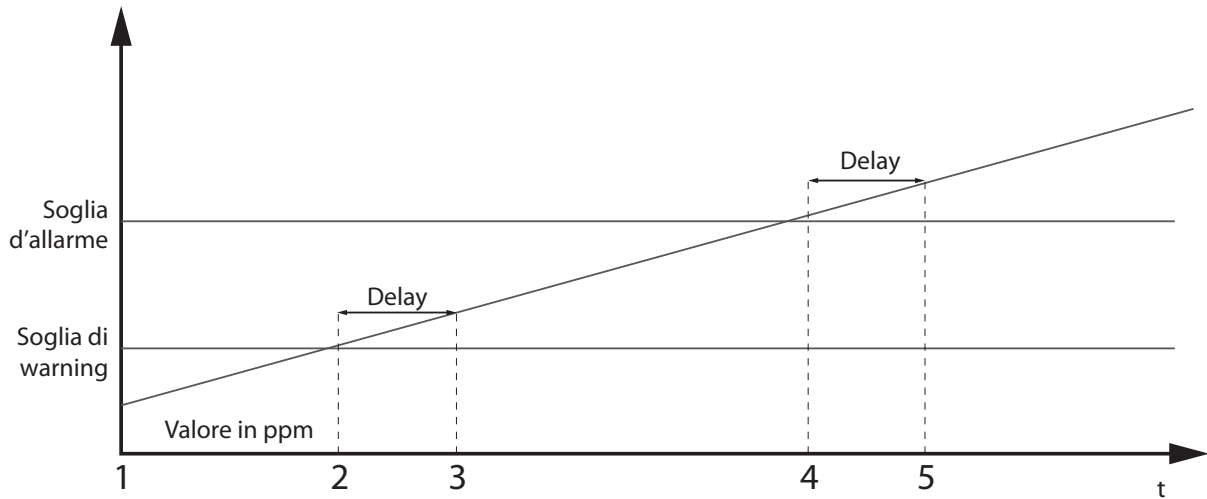

1	2	3	4	5
300 PreAlarmflag = 0	300 PreAlarmflag = 0	300 PreAlarmflag = 0	300 PreAlarmflag = 1	300 PreAlarmflag = 1
307 PreWarningFlag = 0	307 PreWarningFlag = 1	307 PreWarningFlag = 1	307 PreWarningFlag = 1	307 PreWarningFlag = 1
308 WarningFlag = 0	308 WarningFlag = 0	308 WarningFlag = 1	308 WarningFlag = 1	308 WarningFlag = 1
309 AlarmFlag = 0	309 AlarmFlag = 0	309 AlarmFlag = 0	309 AlarmFlag = 0	309 AlarmFlag = 1
Yellow LED OFF	Yellow LED flashing	Yellow LED ON	Yellow LED ON	Yellow LED ON
Red LED OFF	Red LED OFF	Red LED OFF	Red LED flashing	Red LED ON
Warning relay OFF	Warning relay OFF	Warning relay ON	Warning relay ON	Warning relay ON
Alarm relay OFF	Alarm relay OFF	Alarm relay OFF	Alarm relay OFF	Alarm relay ON

### 3.6 Magnetic key for configuration

The device is supplied with a magnet for configuration, located inside one of the two plastic frames on the GLD. By placing it in the slot provided, the following functions can be managed:

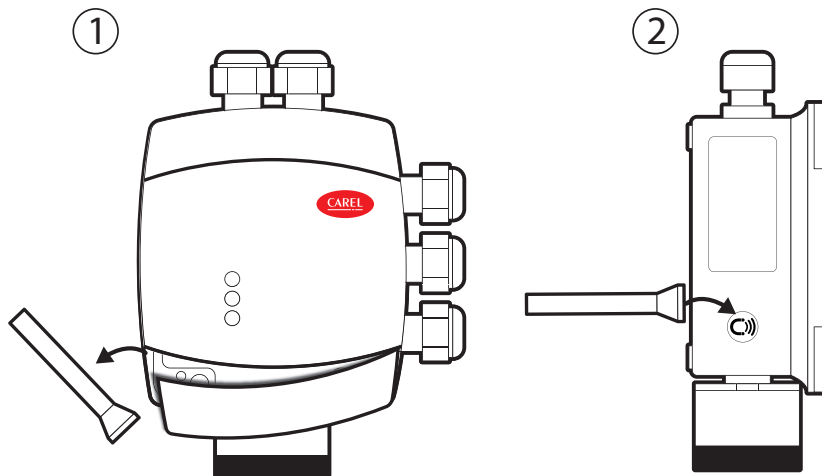

#### Bluetooth activation

After 5 seconds of exposing the magnet to the magnetic sensor, Bluetooth mode is activated. If Bluetooth is already on, after 5 seconds of exposure Bluetooth is deactivated.

Bluetooth mode is automatically deactivated after 20 minutes of inactivity. Product operation in Bluetooth mode is indicated by the rapid flashing of the green LED.

Bluetooth Activation set up the product on installation and maintenance operating mode, the alarms if present are disabled, until the normal operating mode is restored, deactivating bluetooth.

#### Alarm/warning management

If a warning or alarm is active, after 2 seconds of exposure, the alarm will be acknowledged and deactivated. If gas is still present, the detector will enter alarm or warning mode as usual, after a 10 minute delay.

## 3.7 RILEVA TE app features



The "RILEVA TE" app lets users fully exploit the potential of the new Carel GLD Small series gas detectors, allowing simple and intuitive interaction with the gas detector. This simplifies configuration by using a smartphone to interface with the CAREL GDS\* gas leakage detectors.

The RILEVA TE app is available on the ANDROID store, and will soon also be available on the IOS store.



RILEVA TE can be used to perform the following functions:

- Configuration: modify alarm thresholds, configure Modbus settings, modify relay behaviour and manage analogue output settings
- Maintenance: check correct functioning of the device
- Calibration, complete with calibration report
- Display of current gas concentration measurement and indication of alarm/fault status

### 3.7.1 Connecting the device via Bluetooth

Before connecting to the device via the RILEVA TE app, first make sure that the BLUETOOTH connection and GEOLOCATION are enabled on the smartphone used.

Make sure that Bluetooth mode has been activated on the GLD small using the magnetic latch, as described in the previous chapter.

It is recommended to wait for the end of the warm-up phase before activating the Bluetooth connection.

The Bluetooth connection should be established during installation or maintenance.

It is not recommended to use the app to monitor the amount of gas measured in the environment.

Activation via magnetic latch is disabled if there are any active alarms/warnings and automatic reset has been set.

If manual reset mode has been selected, Bluetooth can be activated, however the alarms are disabled during connection.

The alarms are in fact disabled when Bluetooth is active.

Open the RILEVA TE app (previously downloaded); the following screen is displayed

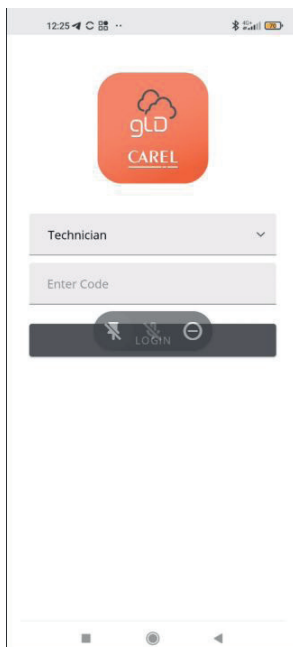

#### Login screen

Select:

- Operator, to continue displaying the gas detector variables and parameters.
- Technician, for password access and the possibility to set the parameters and variables.

The password to unlock the device is 2222.

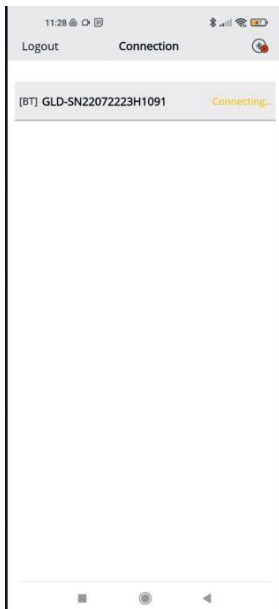

**Bluetooth connection screen:**

If all the functions described above have been enabled on the smartphone and the GLD is in Bluetooth mode, the available devices are shown on the app screen. If this is not the case, touch the app screen to refresh the display.

Verify that the serial number on the label of the device being connected matches the one displayed on the screen.

Select the correct device and verify correct connection. The Bluetooth symbol at the top right changes from red to green.

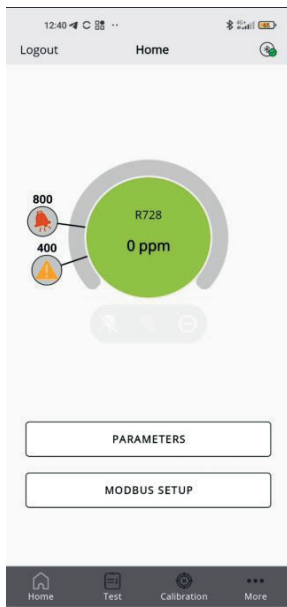

**Home screen:**

From the home screen, it is possible to display the current concentration level measured by the sensor, with the corresponding alarm and warning thresholds.

The following screens can also be accessed:

- PARAMETERS
- MODBUS SETUP
- Test
- Calibration
- More

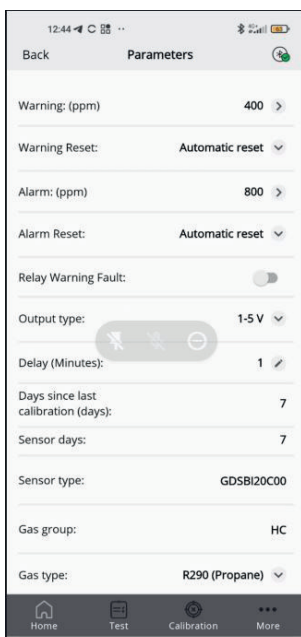

**PARAMETERS screen:**

This screen displays the sensor parameters.

It is also possible to select the type of gas to be detected, from those that are compatible with the sensor; see the Other information chapter in this manual for further details.

The following parameters can be displayed and modified if the user is logged with Technician access

- Warning threshold
- Warning reset: manual or automatic
- Alarm threshold
- Alarm reset: manual or automatic
- Warning relay setting with Fault
- Type of analogue output
- Alarm delay.
- The specific gas to be detected

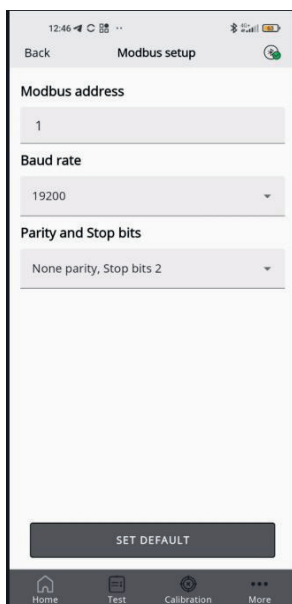
**Modbus setup screen:**

the following parameters can be set:

- Modbus address
- Baud rate
- Parity and stop bits.

Pressing SET DEFAULT sets the default parameters shown in the table in the Modbus setup paragraph.

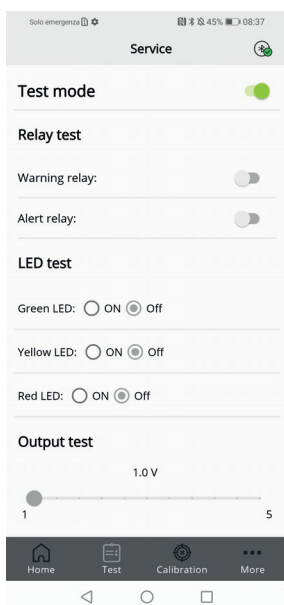
**Test mode screen:**

If enabled, the following functions can be activated in test mode, i.e. not corresponding to the behaviour of the device, rather for debugging:

- Warning relay
- Alarm relay
- Green LED
- Red LED
- Yellow LED
- Analogue output.

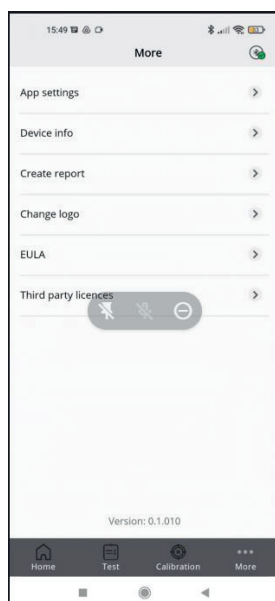
**More screen:**

this displays the app technical and legal information.

- App settings, change the unit of measure for the temperature displayed in the app
- Device Info, view information on the currently connected device
- Create report: to make a copy of the most recent report generated
- Change logo, to replace the default logo that is shown on the calibration certificate with a different one
- EULA, to display the app's legal information
- Third party license, see information on the third-party licenses used.



**IMPORTANT:** the Calibration screen is explained in detail in paragraph 6.2 CALIBRATION VIA APP.

### 3.8 Modbus® network

For the Modbus RS485 network, use a shielded 3-wire cable. Recommended: Belden 3106A (or equivalent).

The Modbus communication parameters can only be set using the Rileva TE app or the rotary switch on the device's electronic board.

Make sure that the network communication parameters are configured in the same way, including on the supervisor.

To ensure optimal operation of the serial network, observe the following guidelines:

- make sure that the devices are configured with a single bus layout; connecting several buses in parallel, or branching several devices from the main bus may introduce incorrect combinations of signal impedance, reflections and/or distortions.
- Avoid using excessively long connections when connecting devices to the serial bus. The device - bus connection must not exceed a maximum length of 1 metre.
- Make sure that the polarity of the A (+, Tx) / B (-, Rx) signal is maintained across the serial network.
- Earth the cable shield only on the main unit side.
- Connect the cable shield to terminal SH on the gas detector.
- Make sure that the shield is intact across the serial network.
- Do not use the shield connection as a signal reference. Use a cable that provides a dedicated wire for the signal reference. Connect the signal reference to terminal GND on the gas detector.

The CAREL GLD series gas detectors feature a Modbus RTU digital interface. All of the status messages and most of the parameters accessible and/or configurable via the Bluetooth® interface are also accessible and/or configurable via a Carel MODBUS controller.

#### Parameters for RS485 communication selectable via app or rotary switch

Parameter	Possible values	Default value
Address	0 to 247 via app 0 to 100 via device	0
Baud rate	9600 or 19200	19200
Stop bits	1 or 2	2
Parity	None, Even or Odd.	None

 **IMPORTANT:** Each device connected to the same RS485 bus must have its own address, otherwise there will be conflicts in transmission/reception that prevent serial communication.

 **IMPORTANT:** The write registers are password-protected. By entering the password in the appropriate register, authorisation to write the variables will be provided for 15 minutes. There is a specific variable that indicates whether or not the device is currently locked.

The password to unlock the device is 2222.

 **IMPORTANT:** When using a CAREL BOSS family supervisor, it is recommended to enter the device unlock password at least once, so that all the devices can be displayed correctly. This is necessary when asterisks (\*\*\*) are displayed in the parameters section instead of the value

### 3.9 Table of Modbus® variables

**Function 04 Read Input Registers**

Address	Register name	Short description	Medium description	Long description	Max value	Min value	Unit of meas.	Modbus Bit pos.	Modbus length	Default value
101	Concentration	Concentration ppm	Sensor concentration in "units"	Sensor concentration in "units"	65535	0		0	16	
102	Status_0	No ICM contact	No contact with the sensor module (ICM)	No contact with the sensor module (ICM)	1	0		0	1	
102	Status_1	No response from the sensor	Sensor module (ICM) signals no contact with the sensor	Sensor module (ICM) signals no contact with the sensor	1	0		1	1	
102	Status_4	Over range	Sensor over range	Sensor over range	1	0		4	1	
102	Status_5	Under range	Sensor under range	Sensor under range	1	0		5	1	
103	Range	Full scale	Sensor full scale	Sensor full scale	65535	0	ppm	0	16	
105	DaysOnline	DaysOnline	Number of days online	Number of days online	65535	0	day	0	16	
106	ModbusAddress	Modbus address	Detector Modbus address	Detector Modbus address	247	0		0	16	0
107	SWVer	SWVer	Firmware version	Firmware version	65535	0		0	16	
108	MachineCode	MachineCode	MachineCode	MachineCode	65535	0		0	16	
113	HWVer	HWVer	Hardware version	Hardware version	39321	0		0	16	
114	SensorType	Sensor type	Connected sensor P/N	Returns the part number of the currently connected product. See the Sensor type table to identify the part numbers of the available products	999	0		0	16	
115	Units	Units	Unit of measure	Unit of measure used to measure the gas, currently only expressed in ppm	999	0		0	16	
116	AnalogOutputValue	Analogue output	Analogue output value	Analogue output value as a percentage	100	0	%	0	16	
117	GasGroup	Gas Group	Gas group listed in the table	1 R32 mixtures, 2 HFC/HFO, 3 HC, 4 CO <sub>2</sub> , 5 NH <sub>3</sub>	5	1		0	16	
118	DaysSinceService	Days since service	Days since last service performed	Days since last service performed	65535	0	day	0	16	
119	MaxDaysOnline	Max days online	Maximum number of days online allowed for the sensor	Maximum number of days online allowed for the sensor before replacement is required	65535	0	day	0	16	
120	MaxDaysToService	Max days to service	Maximum days until next service	Maximum days until next service	65535	0	day	0	16	365

**Function 06 Write Single Register & Function 16 Write Multiple Register**

Address	Register name	Short description	Medium description	Long description	Max value	Min value	Unit of meas.	Modbus Bit pos.	Modbus length	Default value
200	LimitAlarm	Alarm limit	Alarm threshold	Alarm threshold	10000	0	ppm	0	16	
201	Delay	Delay	Delay before alarm activation	Delay before alarm activation	20	0	min	0	16	0
203	LimitWarning	Warning limit	Warning threshold	Warning threshold	10000	0	ppm	0	16	
204	AnalogOutputType	Type of analogue output	Type of analogue output signal	2 = 4-20mA ; 5 = 1-5V ; 8 = 2-10V ; 10 = 0-10V	10	2		0	16	2
205	PassCode	PassCode	Password to authorise the next command	Password to authorise the next command	65535	0		0	16	
206	GasType (*)	Type of gas	Gas type value	Gas type value	50	0		0	16	
655	SpanConcentration	SpanConcentration	Span concentration for calibration	Span concentration for calibration	10000	0	ppm	0	16	0

**Function 04 Read Input Registers**

Address	Register name	Short description	Medium description	Long description	Max value	Min value	Unit of meas.	Modbus Bit pos.	Modbus length	Default value
300	PreAlarmFlag	Alarm flag	Indicator of whether the alarm threshold has been exceeded	1 = alarm threshold exceeded	1	0		0	1	0
302	Fault	Fault	Fault indication	1 = fault. See register 102 to identify the type of fault that has occurred	1	0		0	1	0
303	W1LED	W1LED	W1 RED status LED	W1 RED status LED	1	0		0	1	0
304	W2LED	W2LED	W2 GREEN status LED	W2 GREEN status LED	1	0		0	1	0
305	W3LED	W3LED	W3 YELLOW status LED	W3 YELLOW status LED	1	0		0	1	0
307	PreWarning-Flag	PreWarning flag	Indicator of whether the warning threshold has been exceeded	1 = warning threshold exceeded	1	0		0	1	0
308	WarningFlag	Warning relay	Warning activation indicator including delay	1 = Warning ON	1	0		0	1	0
309	AlarmFlag	Alarm relay	Alarm activation indicator including delay	1 = Alarm on	1	0		0	1	0
310	BTStatus	BTStatus	Bluetooth status	1 = Bluetooth on	1	0		0	1	0

## Function 04 Read Input Registers

Address	Register name	Short description	Medium description	Long description	Max value	Min value	Unit of meas.	Modbus Bit pos.	Modbus length	Default value
311	SensorExpired	Sensor expired	Flag showing if the sensor needs to be replaced	1 = sensor to be replaced	1	0		0	1	0
312	DeviceUnlocked	Device unlocked	Indicator for authorisation to modify variables	1 = dispositivo unlocked	1	0		0	1	0

## Function 05 Write Single Coil &amp; Function 01 Read Coils

Address	Register name	Short description	Medium description	Long description	Max value	Min value	Unit of meas.	Modbus Bit pos.	Modbus length	Default value
401	ServiceDue	Service needed	Maintenance indicator (including calibration).	1 = maintenance required	1	0		0	1	0
402	Acknowledge	Acknowledge	Manual reset for warning/ alarm	1 = manual warning/alarm reset. The fault alarm cannot be disabled	1	0		0	1	0
403	RelayFailSafe	Relay FailSafe	Relay in failsafe mode	1 = Relay in failsafe mode	1	0		0	1	0
404	RelayWF	Relay WF	Warning relay used as fault	1 = Warning relay used as fault	1	0		0	1	0
405	AcknowledgeWarning	Acknowledge warning	Manual/automatic warning acknowledgement setting	1 = automatic reset; 0 = manual reset	1	0		0	1	0
406	AcknowledgeAlarm	AcknowledgeAlarm	Manual/automatic alarm acknowledgement setting	1 = automatic reset; 0 = manual reset	1	0		0	1	1
407	ZeroCalibration	Zero calibration	Start zero calibration command	1 = start calibration	1	0		0	1	1
408	SpanCalibration	SpanCalibration	Start span calibration command	1 = start span calibration	1	0		0	1	0
409	FactoryReset	Reset	Reset the detector to the factory settings	1 = restore factory settings	1	0		0	1	0

## Sensor type table

ID	Part number	Description
0	GDSBI20C00	Gas Detector Small R-744 (Co2) Infrared Wall Built-In
1	GDSBE19C00	Gas Detector Small R-717 (Ammonia) Electrochemical Wall Built-In
2	GDSBSMXC00	Gas Detector Small Group 1 Semiconductor Wall Built-In
3	GDSBSHFC00	Gas Detector Small Group 2 Semiconductor Wall Built-In
4	GDSBSHCC00	Gas Detector Small Group 3 Semiconductor Wall Built-In
5	GDSRI20C00	Gas Detector Small R-744 (Co2) Infrared Wall Remote
6	GDSRE19C00	Gas Detector Small R-717 (Ammonia) Electrochemical Wall Remote
7	GDSRSMXC00	Gas Detector Small Group 1 Semiconductor Wall Remote
8	GDSRSHFC00	Gas Detector Small Group 2 Semiconductor Wall Remote
9	GDSRSHCC00	Gas Detector Small Group 3 Semiconductor Wall Remote
10	GDOPZI2010SP	Pre-Calibrated Sensor Module Small - R-744 (Co2) Infrared
11	GDOPZE1910SP	Pre-Calibrated Sensor Module Small - R-717 (Ammonia) Electrochemical
12	GDOPZSMX10SP	Pre-Calibrated Sensor Module Small - Group 1 Semiconductor
13	GDOPZSHF10SP	Pre-Calibrated Sensor Module Small - Group 2 Semiconductor
14	GDOPZSHC10SP	Pre-Calibrated Sensor Module Small - Group 3 Semiconductor
15	GDOPZT0000	Gas Detector - Calibration Kit For Small Edition

## 3.9.1 Meaning of the operating timers

- **MaxDaysOnLine:** This is the sensor operating time expressed in days. The value depends on the sensor technology: semiconductor, infrared or electrochemical.
- **DaysOnLine:** Number of days since the sensor was powered on. When the value is greater than MaxDaysOnLine, the SensorExpired flag will be active.
- **MaxDaysToService:** Time expressed as a number of days after which calibration is required.
- **DaysSinceService:** Number of days since the sensor was powered on following the last calibration. When the value is greater than MaxDaysToService, the ServiceDue flag will be active.

## 4. MAINTENANCE

### 4.1 Calibration procedure

The calibration procedure is performed periodically and involves introducing a known gas concentration at the sensor inlet, using the calibration kit.

The need to perform calibration is signalled by a specific variable on the supervisor. Each type of device has a different calibration interval, as described in the technical specifications table. After a few years of operation, the sensor needs to be replaced, as described in the following chapters, as the calibration is no longer sufficient to guarantee reliability of the measurement performed.

Calibration is performed by connecting the kit described in the following chapter. It is also recommended to read the chapters on calibration via app or supervisor before connecting the kit, so as to choose the most suitable calibration method.

For semiconductor versions (group, 1, 2, 3), it is recommended to wait at least 48 hours between exposures to the gas, to allow the sensor to reset and make a correct measurement. The sensor should be exposed to the known gas concentration for a limited time: recommended time 3 minutes, maximum 5 minutes.

**▶ IMPORTANT:** the semiconductor versions are designed to detect different types of gases, as described under "Further information"; however, the calibration procedure does not use one of these gases, rather the default gas. The complete table of gases to be used for each type of product is shown under "Gases detected".

It is therefore recommended to only use the specific gas for each group to perform the calibration procedure.

The CO<sub>2</sub> detectors do not require periodic calibration, but simply replacement of the sensor after a approximately 7 years. Calibration can be performed every 12 months if wanting to guarantee greater accuracy of the measurement or if needing to issue a new calibration certificate. Below is a description of how to calibrate via the supervisor or via the app.

### 4.2 Calibration kit

The calibration kit is used to perform periodic calibration required for maintenance of the device. The gas cylinder and pressure adapter to perform the calibration need to be procured separately.



Calibration kit with adapter, humidifier

The following section describes how to connect the calibration kit to the sensor in order to complete the calibration procedure in the most suitable way.



Once the required gas cylinder is available, screw the pressure reducer onto the cylinder, keeping the valve closed so that no gas is released.



Screw the highlighted part of the calibration kit onto the sensor on the product being calibrated.

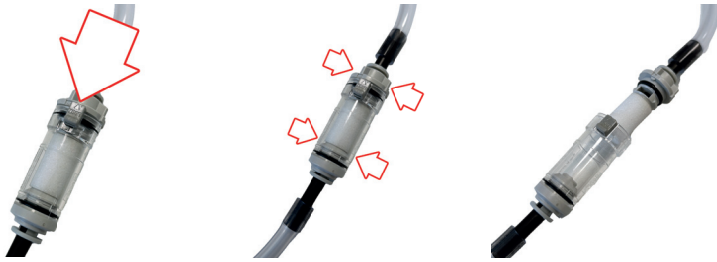

Remove the cylinder by pressing the lever and then detaching the two parts.



Immerse the cylinder in a container filled with tap water for a few seconds.

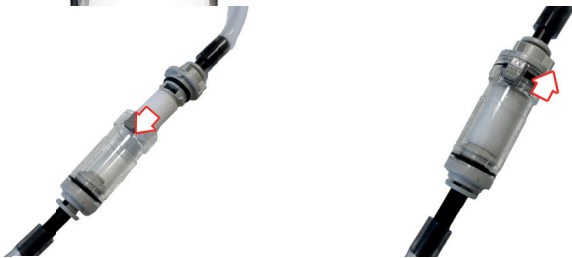

Place it back in the previous position and close the filter, as shown in the figure.

**Note** the direction of air flow (towards the sensor).



Assemble the various components as shown in the figure, without connecting the tube to the GLD.



Open the regulator on the gas cylinder to a pressure of around 0.5 l/min and let the gas flow for a few seconds without the calibration adapter connected to the sensor, then connect the tube to the GLD.

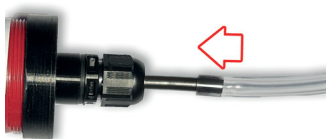

Alternatively, to vent any residual air from the kit, before fixing the cap to the sensor, let some gas flow out for a few seconds.

### 4.3 Calibration via app

Before connecting to the device via the RILEVA TE app, first make sure that the BLUETOOTH connection and GEOLOCATION are enabled on the smartphone used.

Make sure that the Bluetooth mode on the GLD small has been activated using the magnetic latch as described in the previous chapters.

Refer to the Functions chapter of the RILEVA TE app manual for details of all the app's features.

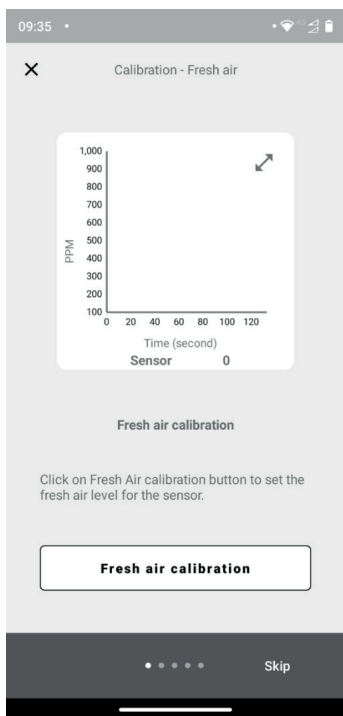

Start calibration on the navigation bar.

Before connecting the calibration kit make sure the sensor is ready and free of gas or other sources of pollution

Click Fresh air calibration at the bottom right, then select Next

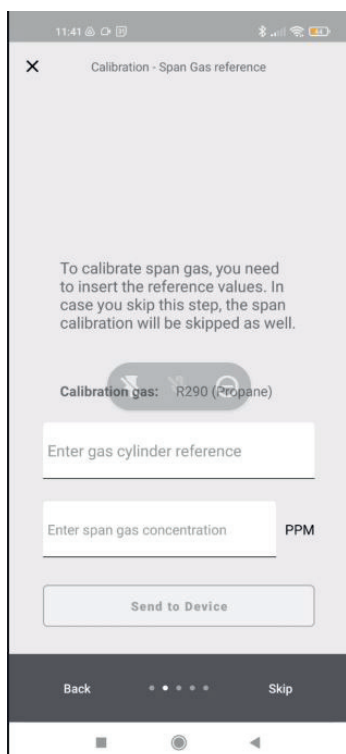

To perform the calibration, the specific gas indicated as the "calibration GAS" needs to be used Enter the gas cylinder reference (serial number of the reference gas or other information to be shown on the certificate).

Enter the concentration of the gas used for calibration

Click send to device to set the gas concentration used for calibration.

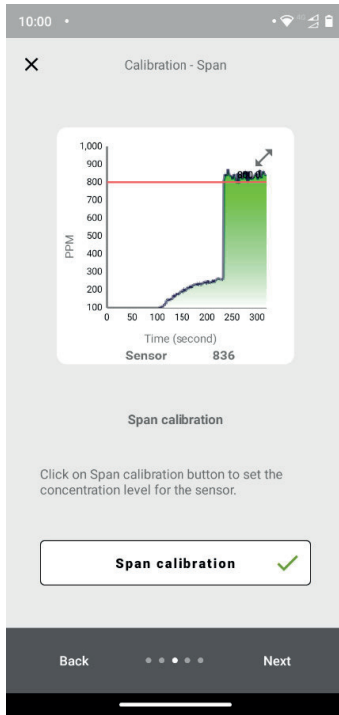
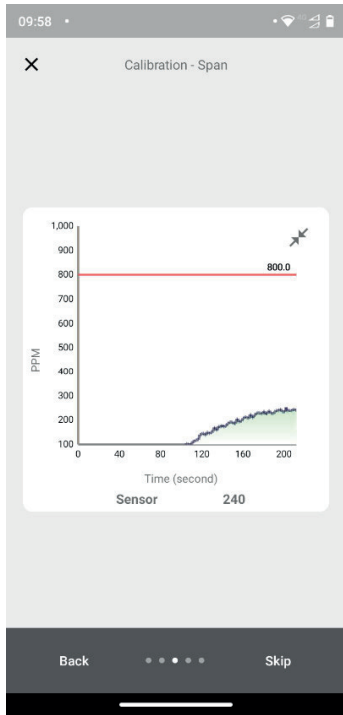

Supply the gas at the known concentration using the calibration kit, suitably installed as described in the previous chapter. Wait about 1 minute until the gas concentration stabilises.

Click Span Calibration to set the calibration concentration.

Enter the room temperature and relative humidity. These values will be entered on the calibration certificate to indicate the environmental conditions during calibration. It is not necessary to use a calibrated instrument to perform this measurement, an indicative value is sufficient.

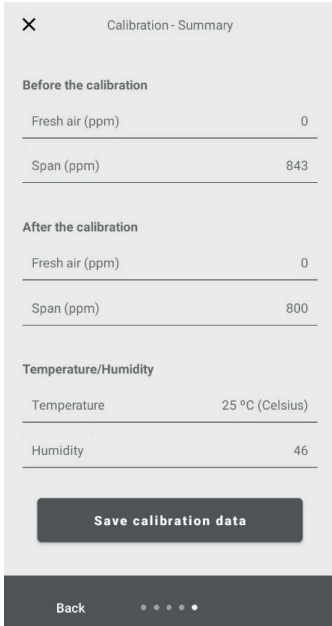

Verify the summary screen, checking that all the information has been entered correctly before generating the calibration report.

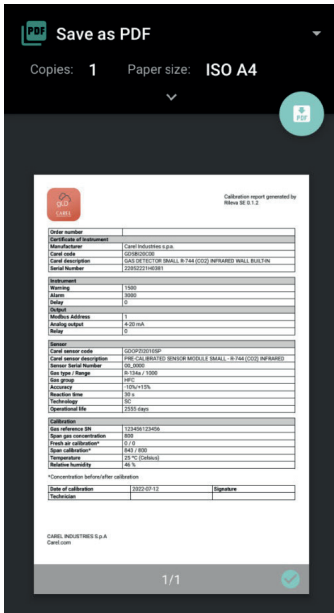

Save the calibration report.  
Use File manager to share the calibration report via email.

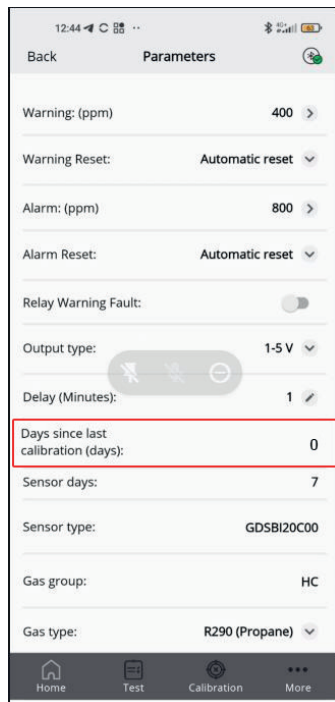

Correct completion of the calibration process can be verified by checking that the value of "Days since last calibration" has been updated to 0.

## 4.4 Calibration via Modbus® communication

Place the sensor in clean air and wait for the warm-up phase to be completed at the end of the start-up phase. Enter the Technician password to access the device (2222 to register 205).

Send 1 to ZeroCalibration (coil 407) to perform the fresh air calibration. If coil 407 is read as 0 after calibration, it means that calibration was successful.

Send the span gas concentration to the SpanConcentration variable (holding register 655).

Supply gas to the sensor. Use the calibration kit and a 0.5 l/min airflow regulator. Wait around 1 minute until the concentration is stable.

Send 1 to SpanCalibration (coil 408). Read as 0 to confirm the calibration was successful.

### 4.4.1 Diagram of the calibration procedure

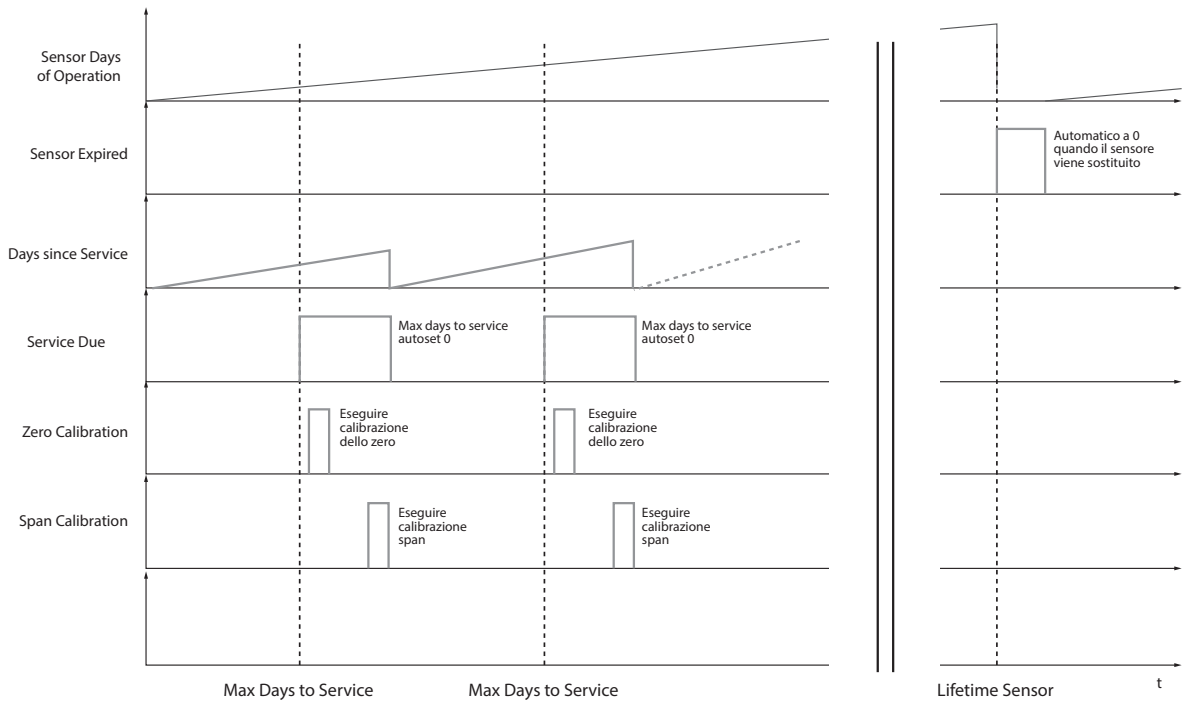

### 4.4.2 Operation of the registers for calibration

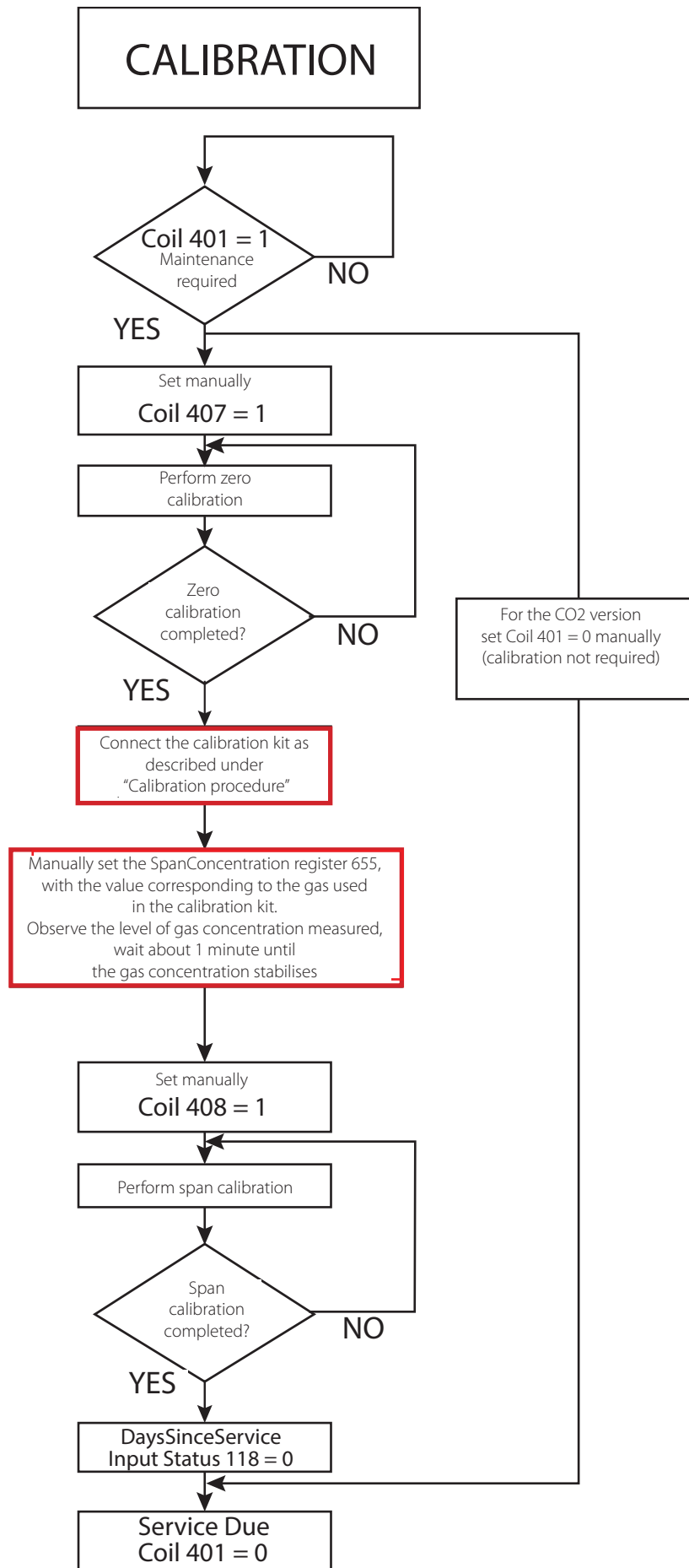

## 4.5 Sensor replacement procedure

When the need for replacement is signalled via Modbus communication (coil 311 SensorExpired), proceed as follows:

- Acquire a pre-calibrated sensor with the same part number as the one mounted on the detector.
- Disconnect power

### 4.5.1 Built-in version:

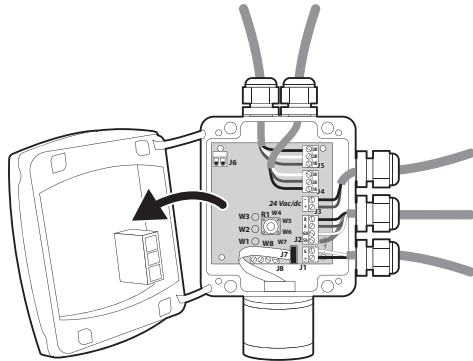

Open the cover

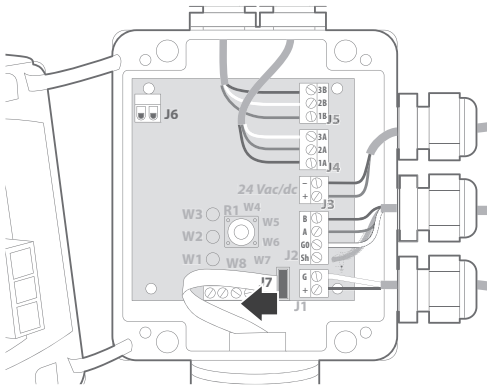

Unplug the pre-calibrated sensor connector from J7

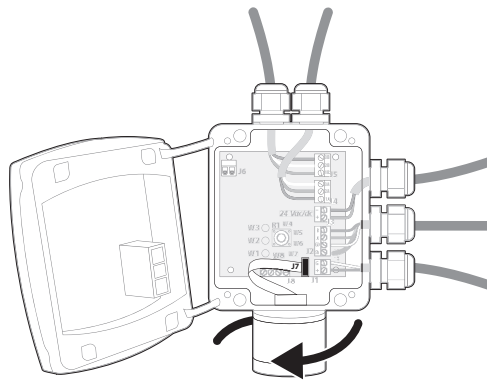

Unscrew the sensor from the inside nut.

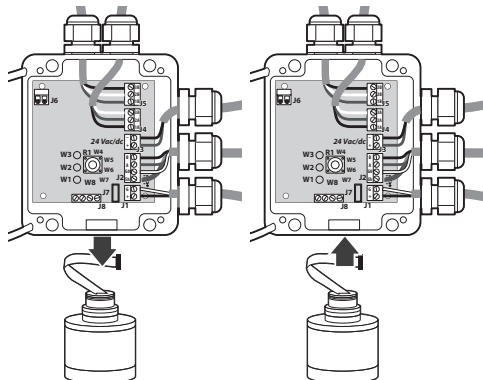

Completely disconnect the pre-calibrated sensor from its housing and replace the pre-calibrated sensor with a new one with the same part number.

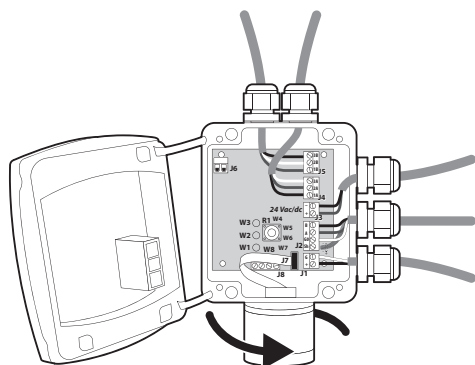

Screw in the new sensor

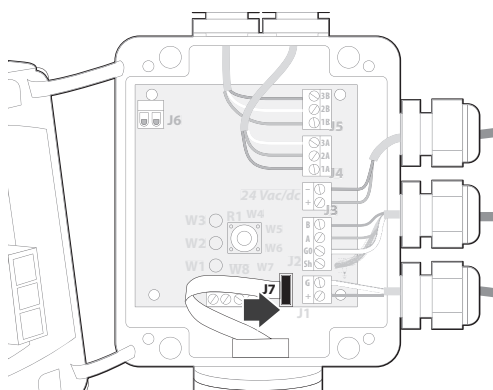

Plug-in the sensor connector to J7

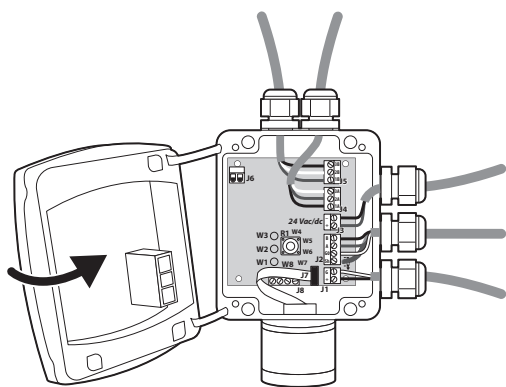

Close the cover

## 4.5.2 Remote version

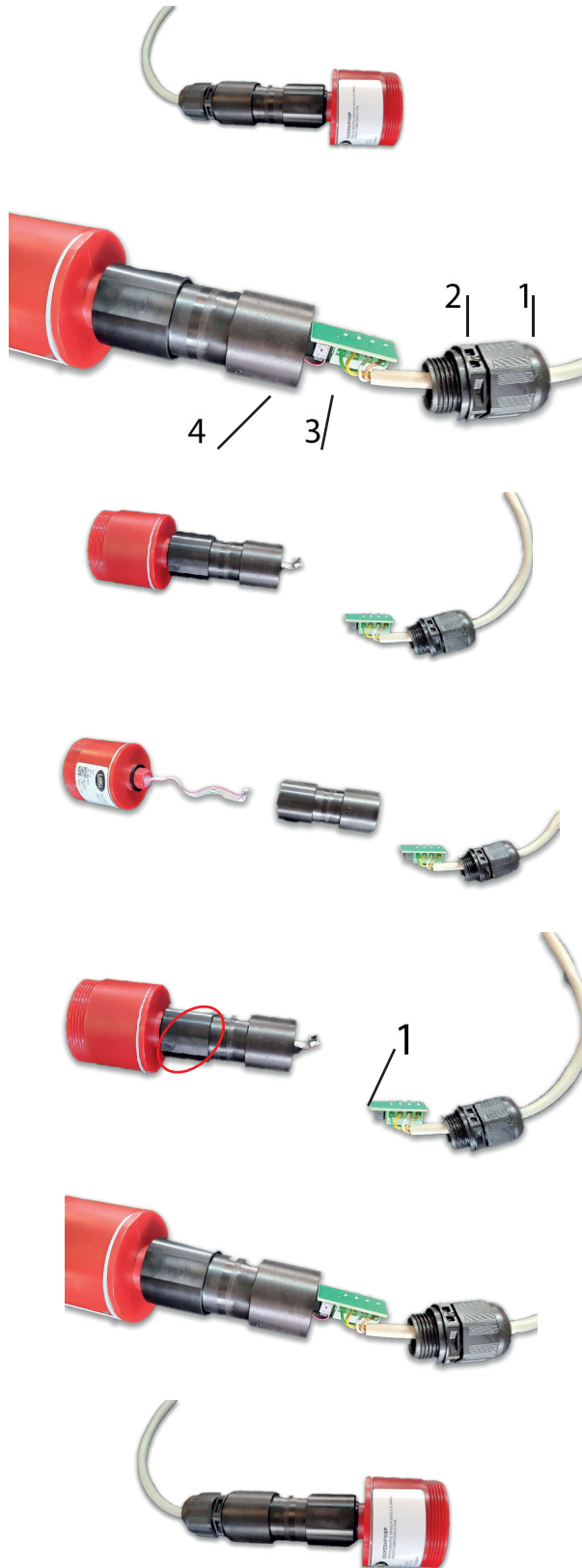

Detach the remote sensor from the housing used to perform the measurement in normal conditions

1. Loosen the screw on the cable gland by unscrewing between points 1 and 4 in the figure, so that the cable is free to move inside the cable gland
2. Completely unscrew the screw positioned in point 2 by unscrewing between points 2 and 4 shown in the figure. In the event of difficulties when loosening, use pliers in point 2
3. Open the container by pulling points 1 and 4 in the figure, between the points, so as to remove the electronic board from its housing

Unplug the sensor connector from the electronic board

Unscrew the sensor from the tube so as to separate it from the other parts of the device

Make sure the new sensor has the same part number as the one just removed.

Screw in the new sensor, making sure to use the highlighted part and not the opposite part.  
Place the electronic board inside the tube, making sure that the connector highlighted in point 1 is positioned in the direction of the sensor.

Plug the connector into the electronic board  
Place the board inside the tube

Screw the cable gland to the tube, making sure that the cable is free to move inside the cable gland.  
Tighten the cable gland on the cable, making sure that the retaining gasket is inside the cable gland.



**IMPORTANT:** this product uses semiconductors that may be damaged by electrostatic discharges (ESD). When handling printed circuit boards, observe proper ESD precautions so as to not damage the electronics.

## 4.6 Cleaning the device

Clean the detector with a soft cloth using water and a mild detergent. Rinse with water. Do not use alcohol, degreasers, sprays, polishes, detergents, etc.

## 5. FURTHER INFORMATION

### 5.1 Sensor operating principle

#### 5.1.1 Semiconductor sensors

Semiconductor or metal-oxide-semiconductor (MOS) sensors are very versatile and can be used in a wide range of applications: they can measure both gases and vapours at low ppm and combustible gases at higher concentrations. The sensor is made from a blend of metal oxides. These are heated to a temperature between 150 °C and 300 °C, depending on the gas to be detected. The operating temperature and composition of oxides determines the selectivity of the sensor with respect to different gases, vapours and refrigerants. Electrical conductivity increases significantly as soon as gas or vapour molecules come into contact with the sensor's surface by diffusion.

When the molecules of the selected gas come into contact with the sensor's surface, the conductivity of the semiconductor material increases significantly, in proportion to the concentration of gas. Consequently, the current running through the sensor also varies. Water vapour, high ambient humidity, temperature fluctuations and low oxygen levels can alter the readings, giving a higher concentration than the actual level.

By using this technology, GLD Small allows the gas detected to be selected based on its category. Gases are divided into three categories or groups. Group 1 includes R32 gases, group 2 those HFCs/HFOs and group 3 HCs.

Depending on the gas to be detected, the specific device that detects that category of gas needs to be purchased, and then the specific gas selected via app or Modbus.

The table in the next chapter shows the list of gases detected and the corresponding group.

For example, if needing to detect R-410A, the required device needs to be purchased, described as "Group 1". At the time of installation, then, select R-410A via app or by setting the corresponding Modbus register.

The product can detect a wide spectrum of gases, setting the desired gas as described above; however the default gas must be used to perform the calibration procedure, as described under "Calibration".



**IMPORTANT:** Products with semiconductor technology may be affected by long-term exposure to high concentrations of gas.

In this case, it is recommended to replace the pre-calibrated sensor only (available separately), to ensure correct gas detection.

#### 5.1.2 Infrared sensors

Infrared technology detects certain types of gas using an electronic sensor that measures the infrared rays (IR) radiated at the wavelength that the gas is sensitive to. This makes it possible to quantify the substance present in the surrounding air.

The NDIR detection method (non-dispersive infrared sensor) uses optical sensors.

The detector output is directly proportional to the absorption of infrared light at the specific wavelength.

#### 5.1.3 Electrochemical sensors

Electrochemical sensors measure the partial pressure of gases in atmospheric conditions. The monitored ambient air diffuses through a membrane into a liquid electrolyte inside the sensor. Immersed in the electrolyte are a measuring electrode, a counter electrode and a reference electrode. An electronic circuit with a potentiometer supplies a constant voltage between the measuring electrode and the reference electrode. The voltage, the electrolyte and the material used to make the electrodes are selected according to the gas being measured, so that this is correctly transformed electrochemically on the electrode for measurement and thus a current is generated that flows through the sensor. The current value is proportional to the concentration of gas. At the same time, oxygen from the ambient air reacts with the counter electrode. At an electronics level, the current signal is amplified, digitised and corrected based on other control parameters (e.g. ambient temperature).

#### 5.1.4 Pre-calibrated sensors and devices

Pre-calibrated sensors and devices are supplied with the calibration certificate included in the packaging, in addition to the instruction sheet.

## 5.2 Gas detected

Register 117 group	Gas group	Technology	Default GAS	Gas calibration
4	CO <sub>2</sub>	Infrared	CO <sub>2</sub>	CO <sub>2</sub>
5	NH <sub>3</sub>	Electrochemical	NH <sub>3</sub>	NH <sub>3</sub>
1	R32 misti Tipo 1	Semiconductor	R32	R32
2	HFC/HFO Tipo 2	Semiconductor	R134a	R134a
3	HC Tipo 3	Semiconductor	R290	R290

Gas	Sensor module group	Range of measurement.	GasType register value
R-1150	3	0-4000 ppm	53
R-1233zde	2	0-1000 ppm	51
R-1234yf	2	0-1000 ppm	27
R-1234ze	2	0-1000 ppm	28
R-1270	3	0-4000 ppm	13
R-134a	2	0-1000 ppm	2
R-22	2	0-1000 ppm	1
R-290	3	0-4000 ppm	7
R-32	1	0-1000 ppm	23
R-404A	2	0-1000 ppm	3
R-407A	1	0-1000 ppm	19
R-407C	1	0-1000 ppm	4
R-407F	1	0-1000 ppm	22
R-410A	1	0-1000 ppm	5
R-448A	1	0-1000 ppm	33
R-449A	1	0-1000 ppm	34
R-450A	2	0-1000 ppm	35
R-452A	1	0-1000 ppm	36
R-452B	1	0-1000 ppm	38
R-454A	1	0-1000 ppm	43
R-454B	1	0-1000 ppm	40
R-454C	1	0-1000 ppm	44
R-455A	1	0-1000 ppm	29
R-464A	1	0-1000 ppm	48
R-465A	1	0-1000 ppm	49
R-466A	1	0-1000 ppm	47
R-468A	1	0-1000 ppm	50
R-50	3	0-4000 ppm	52
R-507A	1	0-1000 ppm	54
R-513A	2	0-1000 ppm	39
R-600A	3	0-4000 ppm	9
R-717	5	0-100 ppm	10
R-744	4	0-10000 ppm	11

## 5.3 Operation of the relays when the instrument is switched on

At power on, the two warning and alarm relays behave as follows:

- stay off for about 20 seconds
- are activated for about 2 seconds
- go off for about 2 seconds
- are reactivated if failsafe mode is set, or remain deactivated if failsafe mode is disabled.

## 5.4 Relay operating modes

The relays have two operating modes, failsafe mode and warning fault mode. These two modes can be used to select the behaviour of the relays based on the required alarms and in the event of sensor malfunction.

### 5.4.1 Failsafe mode

The relays are set by default to failsafe mode. In this mode, the relays are active when there are no alarms, they are automatically deactivated in the event of an alarm or in the event of a power failure (device off). In this case, the wiring is as follows:

Powered on - no alarms

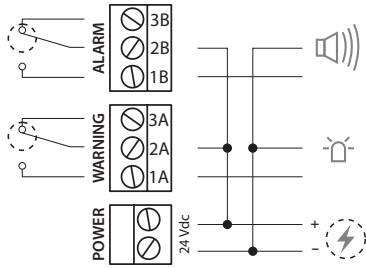

Gas detected (alarm active)

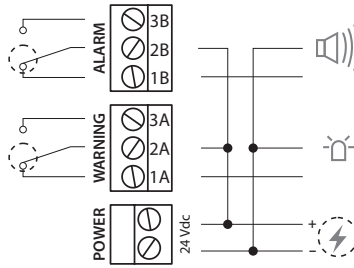

No power supply (alarm active)

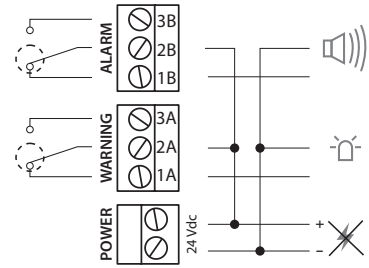

The relays switch over in the event of an alarm or power failure. This setting can be changed by setting the RelayFailSafe variable on the supervisor, so that the relays are activated in normal, non-failsafe mode. In this case, the wiring is as follows:

Powered on - no alarms

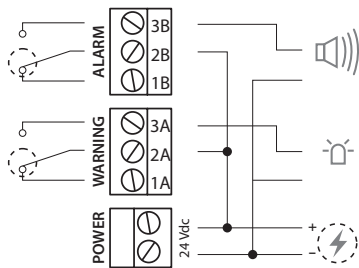

Gas detected (alarm active)

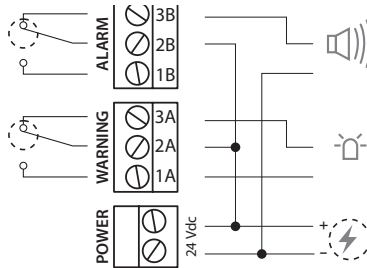

No power supply

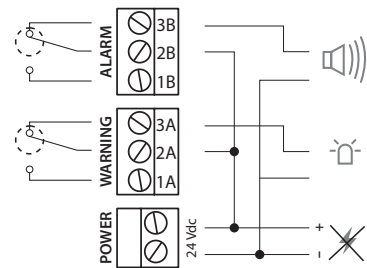

### 5.4.2 Warning Fault mode

In this operating mode, the behaviour of the relays can be set in the event of a malfunction or no communication between the pre-calibrated sensor and the main board.

This operating mode can be enabled or disabled from the supervisor by setting the RelayWF variable or from the parameters section of the app.

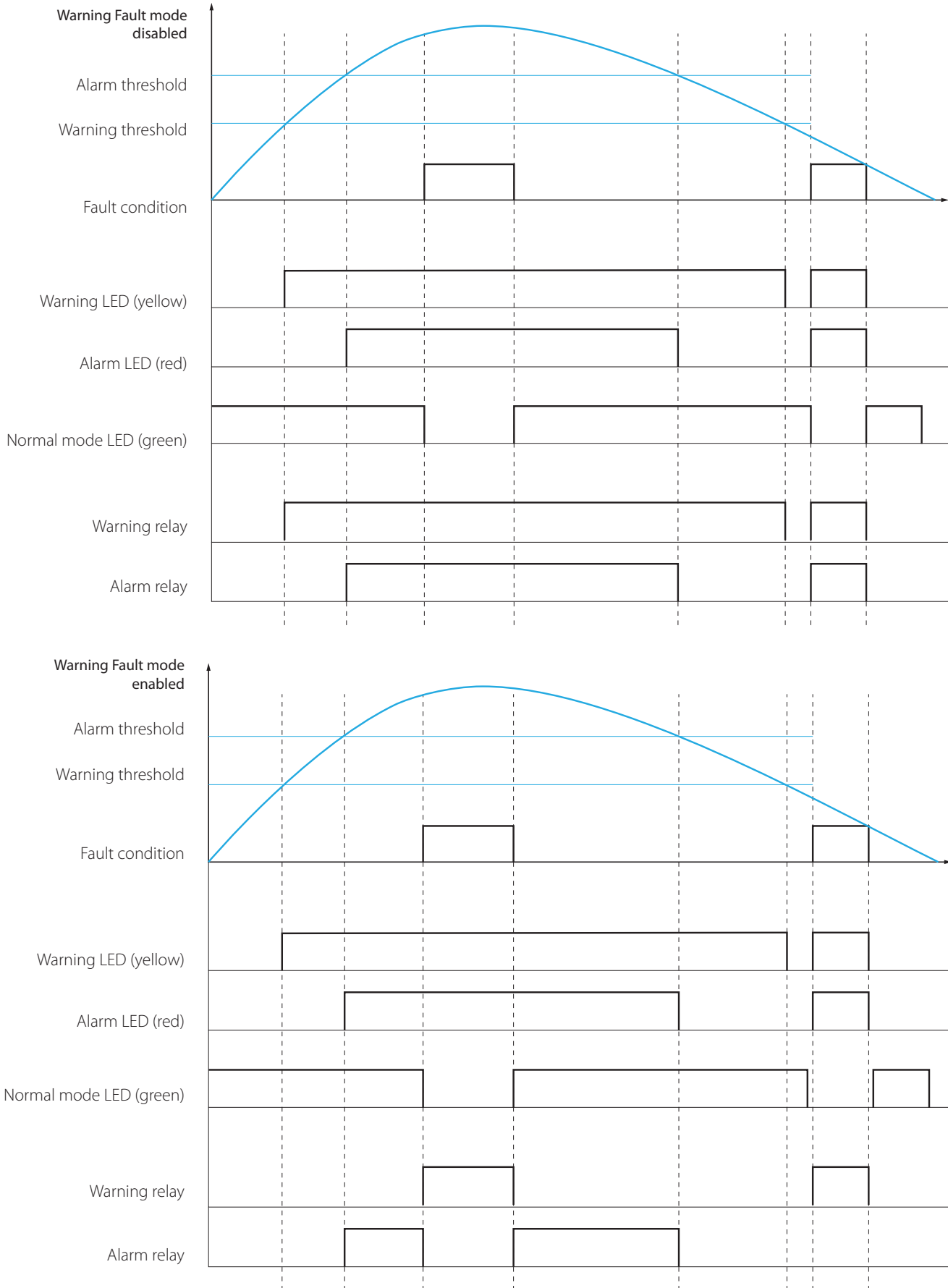

## 5.5 Technical specifications

Technical specifications	Semiconductor version	Electrochemical version	Infrared version
Power supply voltage	24Vdc/ac +/-20% 50/60 Hz		
User interface	App with Bluetooth		
Power input	24 Vdc Max. 4W 24Vac Max 4VA		
Power supply frequency	50/60 Hz		
Analogue output:	4-20mA / 0-10V / 1-5V / 2-10V selected via software		
Serial communication:	Modbus® RS485 isolated slaves		
Digital output 1 SPDT:	Alarm - relay 1 A/24 Vdc/ac		
Digital output 2 SPDT:	Warning/FAULT - relay 1 A/24 Vdc/ac		
Relay failsafe	Yes, selectable		
Selectable delay:	0-20 min; 1 minute steps, selectable via Modbus register/app		
Hysteresis	± 5% of the threshold value		
IP protection:	IP67		
Typical operating range:	0-1000 ppm 0-4000 ppm	0-100 ppm	0-10000 ppm
Sensitive element	Pre-calibrated (also available as a spare part) with certificate		
Remote cable length	5 metres		
Storage temperature	-40 °C to +50 °C.		
Storage humidity	5-90% relative humidity, non-condensing.		
Storage position	Any		
Operating temperature	-40 °C to +50 °C.		
Operating humidity	5-90% relative humidity, non-condensing.		
Maximum installation altitude	2.000 metres		
Operating position	Intended for vertical mounting with the sensor at the bottom		
Precision*	<-10%/+15%	±5%	±5%
Start-up time*	60 minutes	5 minutes	2 minutes
Working life *	5 years	2 years	7 years
Calibration procedure requirements	12 months	12 months	Not required
Sensor deterioration on exposure to high gas concentrations	High	High	Low

\*Reference conditions at 25°C 50% RH atmospheric pressure 101.3 kPa

### 5.5.1 Specifiche meccaniche e ambientali

Dimensions	Enclosure size (WxHxD) (approx.)	Built-in: 233x175x97 mm Remote: 233x175x97 mm
	Product weight + casing (approx.)	Built-in: 590 g Remote: 850 g

## 5.6 Disposal of the device

### 5.6.1 Disposal of electrical and electronic equipment

Since August 2012, rules governing the disposal of electrical and electronic equipment defined in European Directive 2012/19/EU (WEEE) and national laws, which apply to this device, have been in force throughout the European Union. Common household appliances can be disposed of via special collection and recycling sites. However, this device has not been registered for home use. Therefore it must not be disposed of using these services. Do not hesitate to contact CAREL if you have any further questions on this topic.

### 5.6.2 Disposal of the sensors

Dispose of the sensors in accordance with local laws.



**DANGER:** Do not throw the sensors into fire, due to the risk of explosion and consequent chemical burns.



**WARNING:** Do not force open the electrochemical sensors.



**WARNING:** Observe local regulations regarding waste disposal. For information, contact your local environmental agency, local government offices or appropriate waste disposal services.

## 5.7 Conformity to standards

- (EMC) 2014/30/EU
- (LVD) 2014/35/EU
- EN61010-1 | UL61010-1/CSA C22.2 No. 61010-1
- EN 378
- EN14624
- EN50270
- EN50271
- IEC 60335-2-40:2018 (A2L refrigerants)
- (RED-FCC) 2014/53/EU

## 6. ORDER INFORMATION

### 6.1 Gas Detector GLD Small series part numbers

CAREL part number	Description
GDSBI20C00	Gas detector small r-744 (co2) infrared wall built-in
GDSBE19C00	Gas detector small r-717 (ammonia) electrochemical wall built-in
GDSBSMXC00	Gas detector small group 1 semiconductor wall built-in
GDSBSHFC00	Gas detector small group 2 semiconductor wall built-in
GDSBSHCC00	Gas detector small group 3 semiconductor wall built-in
GDSRI20C00	Gas detector small r-744 (co2) infrared wall remote
GDSRE19C00	Gas detector small r-717 (ammonia) electrochemical wall remote
GDSRSMXC00	Gas detector small group 1 semiconductor wall remote
GDSRSHFC00	Gas detector small group 2 semiconductor wall remote
GDSRSHCC00	Gas detector small group 3 semiconductor wall remote

Tab. 6.a

### 6.2 Sensitive element part numbers

CAREL part number	Description
GDOPZI2010SP	Pre-calibrated sensor module small - r-744 (co2) infrared
GDOPZE1910SP	Pre-calibrated sensor module small - r-717 (ammonia) electrochemical
GDOPZSMX10SP	Pre-calibrated sensor module small - group 1 semiconductor
GDOPZSHF10SP	Pre-calibrated sensor module small - group 2 semiconductor
GDOPZSHC10SP	Pre-calibrated sensor module small - group 3 semiconductor

Tab. 6.b

### 6.3 Accessories

CAREL P/N	Description
GDOPZT0010	GAS DETECTOR - CALIBRATION KIT FOR SMALL EDITION

Tab. 6.c

### 6.4 Detected gases (semiconductor versions)

Group 1	R-32 - R-407A - R-407C - R-407F - R-410A - R-448A - R-449A - R-452A - R-452B - R-454A - R-454B - R-454C - R-455A - R-464A - R-465A - R-466A - R-468A - R-507A
Group 2	R-22 - R-134a - R-404A - R-450A - R-513A - R-1234yf - R-1234ze - R-1233zde
Group 3	R-50 - R-290 - R-600A - R-1150 - R-1270

# 7. MOUNTING TEMPLATE

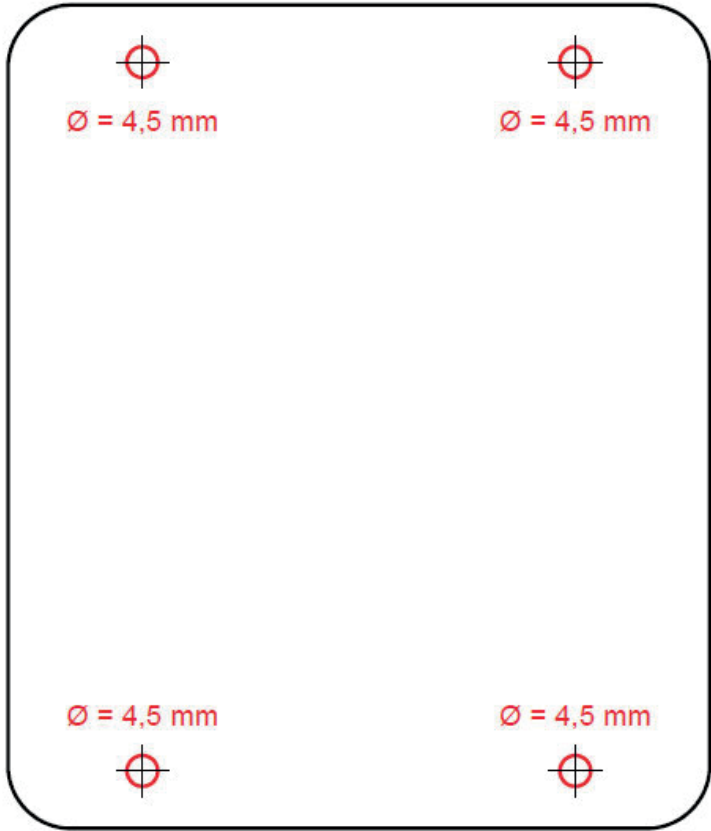





# CAREL

---

**CAREL INDUSTRIES - Headquarters**

Via dell'Industria, 11 - 35020 Brugine - Padova (Italy)  
Tel. (+39) 049.9716611 - Fax (+39) 049.9716600  
e-mail: [carel@carel.com](mailto:carel@carel.com) - [www.carel.com](http://www.carel.com)

Gas Leakage Detector +0300047IE rel 1.1 - 26.04.2023