

KAISAI



**WE
CARE
ABOUT
AIR**

OWNER'S & INSTALLATION MANUAL

SPLIT TYPE AIR CONDITIONER

EN

KFS-50 HRFI/ KFS-50HRFO

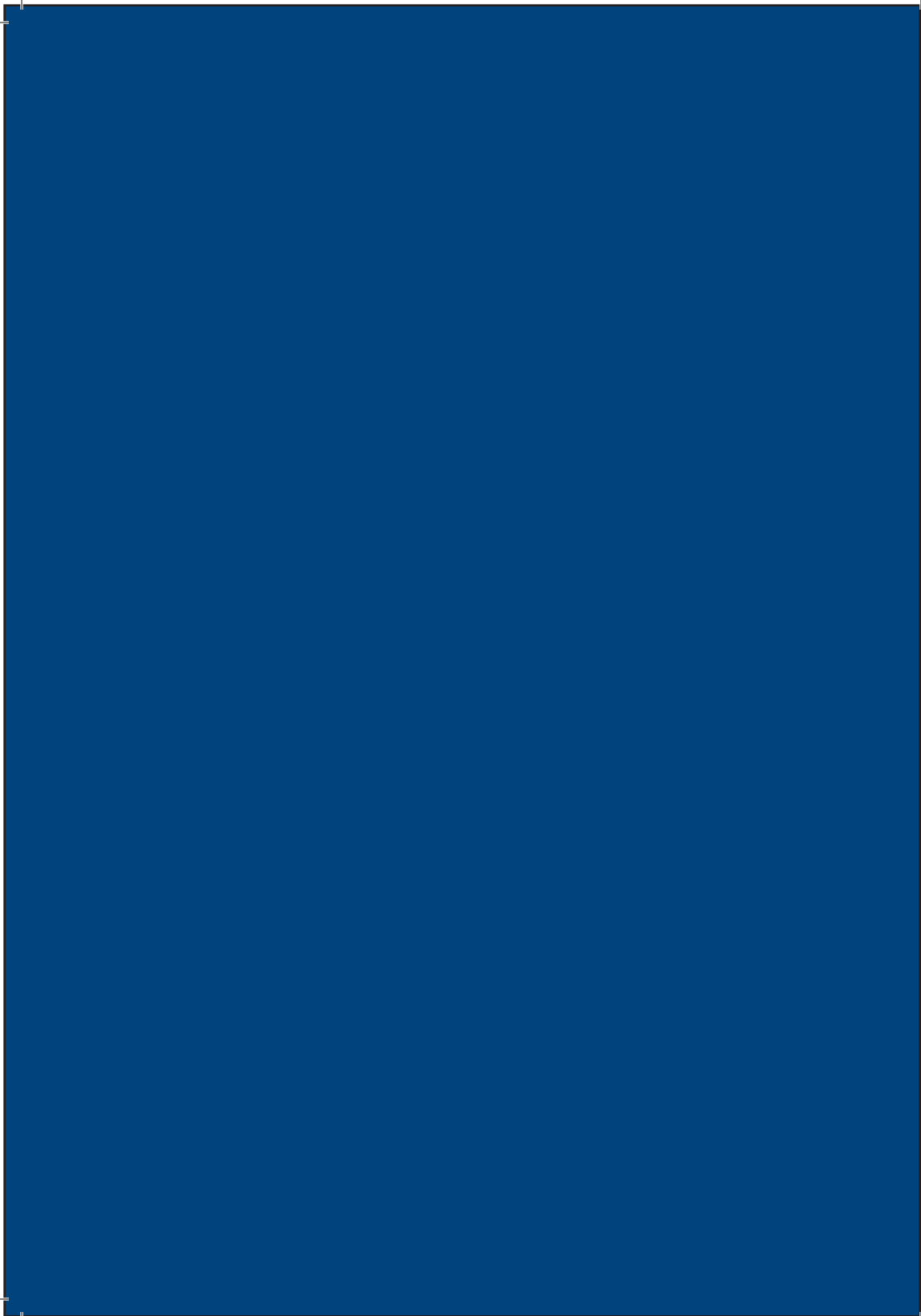

OWNER'S & INSTALLATION MANUAL

SPLIT TYPE AIR CONDITIONER 5
INSTALLATION INSTRUCTIONS 24
AIR CONDITIONER REMOTE CONTROLLER 49

EN

5



KAISAI

SPLIT TYPE AIR CONDITIONER

Owner's & Installation Manual



Thank you for choosing our product.
For proper operation, please read and keep this manual carefully.

If you have lost the Owner's Manual, please contact the local agent or visit www.kaisai.com
or sent email to: handlowy@kaisai.pl, for electronic version.

Table of Contents

Operating Instructions

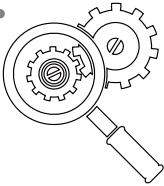
1	Safety Precautions	08
2	Indoor Unit Parts and Major Functions	13
3	Manual Operations	15
4	Care and Maintenance	18
5	Troubleshooting	20



Installation Instructions

6	Accessories	24
7	Installation Overview	25
8	Indoor Unit Installation	26



9	Outdoor Unit Installation	30
----------	--	-----------

10	Drainpipe Installation	33
-----------	-------------------------------------	-----------



11	Refrigerant Piping Connection	34
-----------	--	-----------

12	Wiring.....	37
-----------	--------------------	-----------

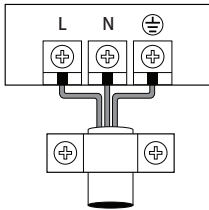

13	Air Evacuation	39
-----------	-----------------------------	-----------

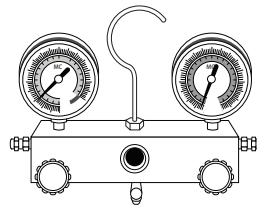

14	Test Run	41
-----------	-----------------------	-----------

15	European Disposal Guidelines	42
-----------	---	-----------

16	Information servicing	43
-----------	------------------------------------	-----------



Caution : Risk of fire
(for R32/R290 refrigerant only)

WARNING:

Servicing shall only be performed as recommended by the equipment manufacturer. Maintenance and repair requiring the assistance of other skilled personnel shall be carried out under the supervision of the person competent in the use of flammable refrigerants. (This is only required for the unit adopts R32/R290 Refrigerant)

Safety Precautions

1

Thank you for purchasing this air conditioner. This manual will provide you with information on how to operate, maintain, and troubleshoot your air conditioner. Following the instructions will ensure the proper function and extended lifespan of your unit.

Read Safety Precautions Before Installation

Incorrect installation due to ignoring instructions can cause serious damage or injury. The seriousness of potential damage or injuries is classified as either a **WARNING** or **CAUTION**.



Failure to observe a warning may result in death. The appliance must be installed in accordance with national regulations.



Failure to observe a caution may result in injury or equipment damage.



This symbol indicates that you must never perform the action indicated.

WARNING

1. Ask an authorized dealer to install this air conditioner. Inappropriate installation may cause water leakage, electric shock, or fire.
2. The warranty will be voided if the unit is not installed by professionals.
3. If abnormal situation arises (like burning smell), turn off the power supply and call your dealer for instructions to avoid electric shock, fire or injury.
4. DO NOT let the indoor unit or the remote control get wet. It may cause electric shock or fire.
5. DO NOT insert fingers, rods or other objects into the air inlet or outlet. This may cause injury, since the fan may be rotating at high speeds.
6. DO NOT use a flammable spray such as hair spray, lacquer or paint near the unit. This may cause fire or combustion.
7. The appliance shall be stored so as to prevent mechanical damage from occurring.
8. Compliance with national gas regulations shall be observed.
9. Carefully read the Safety Precautions before installation.
10. In certain functional environments, such as kitchens, server rooms, etc., the use of specially designed air-conditioning units is highly recommended.
11. Only trained and certified technicians should install, repair and service this air conditioning unit.
12. Improper installation may result in electrical shock, short circuit, leaks, fire or other damage to the equipment and personal property.
(In North America, installation must be performed in accordance with the requirement of NEC and CEC by authorized personnel only.)
13. Strictly follow the installation instructions set forth in this manual.
14. Before you install the unit, consider strong winds, typhoons and earthquakes that might affect your unit and locate it accordingly. Failure to do so could cause the equipment to fail.

WARNING

15. This appliance can be used by children aged from 8 years and above and persons with reduced physical, sensory or mental capabilities or lack of experience and knowledge if they have been given supervision or instruction concerning use of the appliance in a safe way and understand the hazards involved. Children shall not play with the appliance. Cleaning and user maintenance shall not be made by children without supervision.
16. Do not use means to accelerate the defrosting process or to clean, other than those recommended by the manufacturer.
17. This appliance is not intended for use by persons (including children) with reduced physical, sensory or mental capabilities or lack of experience and knowledge, unless they have been given supervision or instruction concerning use of the appliance by a person responsible for their safety.
18. Children should be supervised to ensure that they do not play with the appliance.. (IEC Standard requirement)
19. If the supply cord is damaged, it must be replaced by the manufacturer, its service agent or similarly qualified persons in order to avoid a hazard.
20. The appliance shall be installed in accordance with national wiring regulations.
21. An all-pole disconnection device which has at least 3mm clearances in all poles, and have a leakage current that may exceed 10mA, the residual current device (RCD) having a rated residual operating current not exceeding 30mA, and disconnection must be incorporated in the fixed wiring in accordance with the wiring rules.
22. The appliance disconnection must be incorporated with an all-pole disconnection device in the fixed wiring in accordance with the wiring rules.
23. Any person who is involved with working on or breaking into a refrigerant circuit should hold a current valid certificate from an industry-accredited assessment authority, which authorises their competence to handle refrigerants safely in accordance with an industry recognised assessment specification.
24. Servicing shall only be performed as recommended by the equipment manufacturer.
25. Maintenance and repair requiring the assistance of other skilled personnel shall be carried out under the supervision of the person competent in the use of flammable refrigerants.
26. The appliance shall be stored so as to prevent mechanical damage from occurring.
27. Keep ventilation openings clear of obstruction.
28. Do not turn on the power until all work has been completed.
29. When moving or relocating the air conditioner, consult experienced service technicians for disconnection and reinstallation of the unit
30. In certain functional environments, such as kitchens, server rooms, etc., the use of specially designed air-conditioning units is highly recommended.
31. Removal of the plug has to be such that an operator can check from any of the points to which he has access that the plug remains removed.
32. If this is not possible, due to the construction of the appliance or its installation, a disconnection with a locking system in the isolated position shall be provided.

CLEANING AND MAINTENANCE WARNINGS

1. Turn off the device and pull the plug before cleaning. Failure to do so can cause electrical shock.



CLEANING AND MAINTENANCE WARNINGS

2. Do not clean the air conditioner with excessive amounts of water.
3. Do not clean the air conditioner with combustible cleaning agents. Combustible cleaning agents can cause fire or deformation. Turn off the device and pull the plug before cleaning. Failure to do so can cause electrical shock.



ELECTRICAL WARNINGS

1. Only use the specified power cord. If the power cord is damaged, it must be replaced by the manufacturer or certified service agent.
2. Keep power plug clean. Remove any dust or grime that accumulates on or around the plug. Dirty plugs can cause fire or electric shock.
3. Do not pull power cord to unplug unit. Hold the plug firmly and pull it from the outlet. Pulling directly on the cord can damage it, which can lead to fire or electric shock.
4. Do not use an extension cord, manually extend the power cord, or connect other appliances to the same outlet as the air conditioner. Poor electrical connections, poor insulation, and insufficient voltage can cause fire.

NOTE: For the product air-to-air air conditioners and heat pumps which above 12 kW cooling power output, please see the technical information from Appendix .



CAUTION

- ⊘ For units that have an auxiliary electric heater, do not install the unit within 1 meter (3 feet) of any combustible materials.
 - ⊘ Do not install the unit in a location that may be exposed to combustible gas leaks. If combustible gas accumulates around the unit, it may cause fire.
 - ⊘ Do not operate your air conditioner in a wet room such as a bathroom or laundry room. Too much exposure to water can cause electrical components to short circuit.
1. The product must be properly grounded at the time of installation, or electrical shock may occur.
 2. Install drainage piping according to the instructions in this manual. Improper drainage may cause water damage to your home and property.
 3. DO NOT touch the air outlet while the swing flap is in motion. Fingers might get caught or the unit may break down.
 4. DO NOT inspect the unit by yourself. Ask an authorized dealer to perform the inspection.
 5. To prevent product deterioration, do not use the air conditioner for preservation purposes (storage of food, plants, animals, works of art, etc.).
 6. DO NOT touch the evaporator coils inside the indoor unit. The evaporator coils are sharp and may cause injury.
 7. DO NOT operate the air conditioner with wet hands. It may cause electric shock.
 8. DO NOT place items that might be affected by moisture damage under the indoor unit.
 9. Condensation can occur at a relative humidity of 80%.
 10. DO NOT expose heat-producing appliances to cold air or place them under the indoor unit.
 11. This may cause incomplete combustion or deformation of the unit due to the heat.
 12. After long periods of usage, check the indoor unit to see if anything is damaged. If the indoor unit is damaged, it may fall and cause injury.

CAUTION

13. If the air conditioner is used together with other heating devices, thoroughly ventilate the room to avoid oxygen deficiency.
14. DO NOT climb onto or place objects on top of the outdoor unit.
15. DO NOT operate the air conditioner when using fumigant insecticides. The chemicals may become layered with the unit and endanger those who are hypersensitive to chemicals.
16. DO NOT let children play with the air conditioner.
17. DO NOT operate the air conditioner in a wet room (e.g. bathroom or laundry room).
18. This can cause electrical shock and cause the product to deteriorate.
19. This appliance can be used by children aged from 8 years and above and persons with reduced physical, sensory or mental capabilities or lack of experience and knowledge if they have been given supervision or instruction concerning use of the appliance in a safe way and understand the hazards involved. Children shall not play with the appliance. Cleaning and user maintenance shall not be made by children without supervision.

Cautions for using R32/R290 refrigerant

1. Installation (Space)
 - That the installation of pipe-work shall be kept to a minimum.
 - That pipe-work shall be protected from physical damage.
 - That compliance with national gas regulations shall be observed.
 - That mechanical connections shall be accessible for maintenance purposes.
 - In cases that require mechanical ventilation, ventilation openings shall be kept clear of obstruction.
 - When disposing of the product is used, be based on national regulations, properly processed.
 - The appliance shall be stored in a well-ventilated area where the room size corresponds to the room area as specified for operation.
 - Spaces where refrigerant pipes shall be compliance with national gas regulations.
2. Servicing
 - Any person who is involved with working on or breaking into a refrigerant circuit should hold a current valid certificate from an industry-accredited assessment authority, which authorises their competence to handle refrigerants safely in accordance with an industry recognised assessment specification.
 - Servicing shall only be performed as recommended by the equipment manufacturer. Maintenance and repair requiring the assistance of other skilled personnel shall be carried out under the supervision of the person competent in the use of flammable refrigerants.
3. Do not use means to accelerate the defrosting process or to clean, other than those recommended by the manufacturer.
4. The appliance shall be stored in a room without continuously operating ignition sources (for example: open flames, an operating gas appliance or an operating electric heater)
5. Do not pierce or burn.
6. Be aware that refrigerants may not contain an odour.
7. Be more careful that foreign matter (oil, water, etc) does not enter the piping. Also, when storing the piping, securely seal the opening by pinching, taping, etc.
For indoor units, use R32 flareless joint assy only when connecting the indoor unit and



Cautions for using R32/R290 refrigerant

connecting piping(when connecting indoors). Use of pipes, flareless nut or flare nuts other than specified, may cause product malfunction, burst piping, or injury due to high internal pressure of the refrigerant cycle caused by any inflow air.

8. Appliance shall be installed, operated and stored in a room with a floor area larger than $X \text{ m}^2$ (Please see the following form). The appliance shall not be installed in an unventilated space, if that space is smaller than $X \text{ m}^2$ (Please see the following form).

Model (Btu/h)	Amount of refrigerant to be charged (kg)	maximum installation height (m)	Minimum room area (m ²)
≤30000	≤2.048	1.8m	4
≤30000	≤2.048	0.6m	35
30000-48000	2.048-3.0	1.8m	8
30000-48000	2.048-3.0	0.6m	80
>48000	>3.0	1.8m	9
>48000	>3.0	0.6m	80

Note about Fluorinated Gasses

1. This air-conditioning unit contains fluorinated greenhouse gasses. For specific information on the type of gas and the amount, please refer to the relevant label on the unit itself or the "Owner's Manual - Product Fiche " in the packaging of the outdoor unit. (European Union products only).
2. Installation, service, maintenance and repair of this unit must be performed by a certified technician.
3. Product uninstallation and recycling must be performed by a certified technician.
4. For equipment that contains fluorinated greenhouse gases in quantities of 5 tonnes of CO₂ equivalent or more, but of less than 50 tonnes of CO₂ equivalent, If the system has a leak-detection system installed, it must be checked for leaks at least every 24 months.
5. When the unit is checked for leaks, proper record-keeping of all checks is strongly recommended.

Explanation of symbols displayed on the indoor unit or outdoor unit (applicable to the unit adopts R32/R290 Refrigerant only):

	WARNING	This symbol shows that this appliance uses a flammable refrigerant. If the refrigerant is leaked and exposed to an external ignition source, there is a risk of fire.
	CAUTION	This symbol shows that the operation manual should be read carefully.
	CAUTION	This symbol shows that a service personnel should be handling this equipment with reference to the installation manual.
	CAUTION	
	CAUTION	This symbol shows that information is available such as the operating manual or installation manual.

Indoor Unit Parts And Major Functions

2

Unit Parts

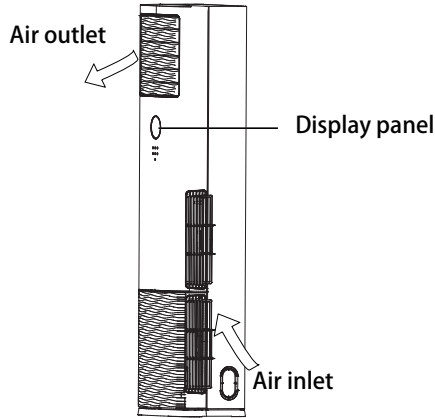

Fig. 2.1

Operating Conditions

Use the system under the following temperatures for safe and effective operation. If the air conditioner is used under different conditions, it may malfunction or become less efficient.

• Inverter Split Type

	COOL mode	HEAT mode	DRY mode
Room Temperature	17°C - 32°C (63°F - 90°F)	0°C - 30°C (32°F - 86°F)	10°C - 32°C (50°F - 90°F)
Outdoor Temperature	0°C - 50°C (32°F - 122°F)	-15°C - 30°C (5°F - 86°F)	0°C - 50°C (32°F - 122°F)
	-15°C - 50°C (5°F - 122°F) (For models with low temp. cooling systems.)		0°C - 52°C (32°F - 126°F) (For special tropical models)
	0°C - 52°C (32°F - 126°F) (For special tropical models)		0°C - 52°C (32°F - 126°F) (For special tropical models)

FOR OUTDOOR UNITS WITH AUXILIARY ELECTRIC HEATER
When outside temperature is below 0°C (32°F), we strongly recommend keeping the unit plugged in at all time to ensure smooth ongoing performance.

• Fixed-speed Type

	COOL Mode	HEAT mode	DRY mode
Indoor Temperature	17°-32°C (63°-90°F)	0°-30°C (32°-86°F)	10°-32°C (50°-90°F)
Outdoor Temperature	18°-43°C (64°-109°F)	-7°-24°C (19°-75°F)	11°-43°C (52°-109°F)
	-7°-43°C (19°-109°F) (low temperature cooling models)		18°-43°C (64°-109°F)
	18°-52°C (64°-126°F) (For special tropical models)		18°-52°C (64°-126°F) (For special tropical models)

Features

Default Setting

When the air conditioner restarts after a power failure, it will default to the factory settings (AUTO mode, AUTO fan, 24°C (76°F)). This may cause inconsistencies on the remote control and unit panel. Use your remote control to update the status.

Louver Angle Memory Function (some models)

Some models are designed with a louver angle memory function. When the unit restarts after a power failure, the angle of the horizontal louvers will automatically return to the previous position. The angle of the horizontal louver should not be set too small as condensation may form and drip into the machine. To reset the louver, press the manual button, which will reset the horizontal louver settings.

Auto-Restart (some models)

In case of power failure, the system will immediately stop. To restart the unit, press the **ON/OFF** button on the remote control. If the system has an auto restart function, the unit will restart using the same settings.

Refrigerant Leak Detection System (some models)

In the event of a refrigerant leak, the LCD screen will display "EC" and the LED indicator light will flash.

For a detailed explanation of each function, refer to the **Remote Control Manual**.

Energy Saving Tips

- **DO NOT** set the unit to excessive temperature levels.
- While cooling, close the curtains to avoid direct sunlight.
- Doors and windows should be kept closed to keep cool or warm air in the room.
- **DO NOT** place objects near the air inlet and outlet of the unit.
- Set a timer and use the built-in SLEEP/ECONOMY mode if applicable.
- If you don't plan to use the unit for a long time, remove the batteries from the remote control.
- Clean the air filter every two weeks.
- Adjust louvers properly and avoid direct airflow.

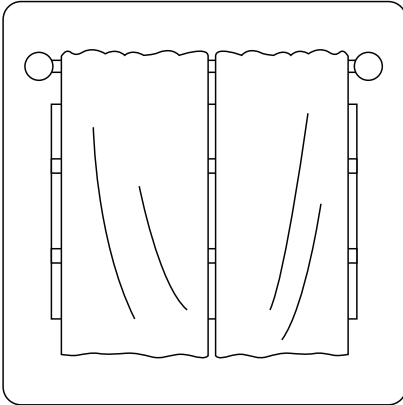

Closing curtains during heating also helps keep the heat in

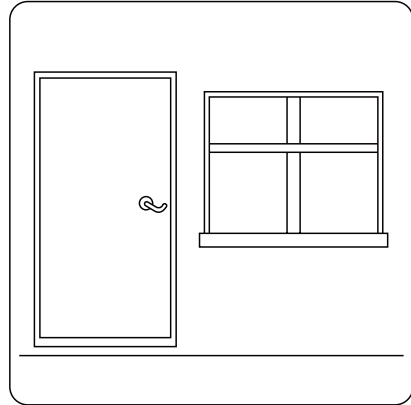

Doors and windows should be kept closed

Manual Operations

3

The display panel on the indoor unit can be used to operate the unit in cases when the remote control has been misplaced or is out of batteries.

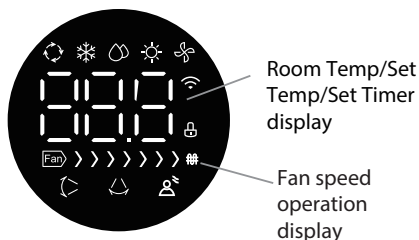

- Auto operation
- Cooling operation
- Dry operation
- Heating operation
- Fan operation
- Vertical airflow
- Horizontal airflow
- Avoid direct
- When wireless control feature is activated (some models)
- Electric heating function (some models)
- Lock operation

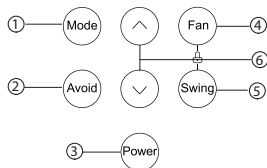

Operation buttons

- ① **MODE** button: Press this button to select the appropriate operating mode. Each time the button is pressed, the operation mode is shifted in the direction of the arrow:



Mode indicators light up to signal the following mode settings.

Auto: Automatically chooses the operation mode by sensing the difference between the actual ambient room temperature and the set temperature on the remote controller. The fan speed is automatically controlled.

Cool: Enables you to enjoy the cooling effect at your preferred setting temperature (Temperature range: 17°C~30°C).

Dry: Enables you to set the desired temperature at medium fan speed which provides you with the dehumidified surroundings (Temperature range: 17°C~30°C). In Dry mode, you cannot select Fan speed and Sleep mode.

Heat: Permits heating operation (For cooling & heating models only, temperature setting range: 17°C~30°C).

Fan only: Permits fan operation without cooling or heating. In this case, however, the setting temperature is not displayed and you cannot adjust the set temperature.

② **Avoid button:**

1. In any mode of boot, press the button to turn on the function.
2. Press "Power", "Swing", "Avoid" close this function.

③ **Power button:** Operation starts when this button is pressed and stops when you press the button again.

④ **Fan button:** This button is used to select the desired fan speed. Each time you push the button, the fan speed is shifted in the following sequence:

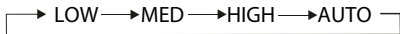

Fan speed display:

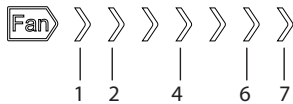

- Select LOW fan speed and zones 1~2 will illuminate.
 - Select MED fan speed and zones 1~4 will illuminate.
 - Select HIGH fan speed and zones 1~6 will illuminate.
 - Select AUTO fan speed and zones 1~7 and "AU" will illuminate .
- Note: When using the remote control to choose strong wind, wind speed 1~7 will illuminate.

⑤ **Swing button:**

1. This button is used to set the horizontal and vertical airflow.
2. Each time the airflow direction button is pressed, the settings change as follows: Set vertical airflow → Cancel vertical airflow → Set horizontal airflow → Cancel horizontal airflow → Set simultaneous vertical and horizontal airflow → Cancel simultaneous vertical and horizontal airflow → Set horizontal airflow.

WARNING: Manually moving the horizontal and vertical airflow direction louvers could damage the air conditioner.

⑥ **▲▼ button**

1. Under the Test Running mode, press "▲" "▼" to be able to check view indoor, outdoor, fault code .
2. When a failure occurs, E0, E1, E3, E4, E5, Eb, EC, E10, F1, F2, F5, P10, P11, P12, P15, P13, P14, P9. (for Fixed-speed Type only)
3. In other states, press the "▲" and "▼" to adjust the temperature within a range of 17°C~30°C, To cut to 17 °C again when press downward adjustments set temperature no longer change; To rise to press adjusted upward again when 30 °C set temperature no longer change. When setting the temperature, the key cannot adjust the temperature quickly, it can only be achieved by pressing up and down.

LOCK FEATURE: The lock feature is activated by pressing down and holding the fan speed and swing buttons simultaneously for a period of one second.

This feature is available both when the unit is turned on or off. The first time these buttons are pressed, the unit locks and all other buttons on the unit are disabled (apart from the unlock button). Please note that the remote control can still be used when the unit is locked. Press the button of the panel and the lock icon will blink for 5 seconds at 1HZ/S. When these buttons are pressed again the unit is unlocked.

Commissioning function: Press "Mode" and "Swing" for one second to open the test run, the key is valid in any mode when it is turned on. On the first time, press this button to enter the test run state. Run the test run for 30 minutes, press this button again, turn off, and exit the test run condition.

The mode key, the wind speed key and the auxiliary function key are not valid, and all other keys are valid (including the key). Press up and down to select the display room (T1), outdoor (outdoor temperature), and protection code, and show "nA" when there is no failure or protection.

NOTE:

Trial operation conditions showed that temperature of T1, if the temperature is less than -15 °C or -19 °C, display temperature of -15 °C or -19 °C.

Trial operation conditions showed that T4 temperature, if the temperature is less than -19 °C, show the temperature for -19 °C.

Trial operation condition, T1, T4 showed highest temperature is 50 °C or 70°C.
Under test mode, sensor fault can be detected.

Wireless control FEATURE (some models):

1. The Wireless control indicator appears when the router has already connected.
2. The Wireless control indicator disappears when the router is not connected.
3. The Wireless control indicator disappears when the Wireless module can't be connected during ten minutes.

NOTE: The Wireless control indicator displays for 15 seconds for the first connection.

AP network configuration:

Press the digital display button on the remote controller seven times or more, the Wireless module will enter into AP mode. A long beep will be heard and the Wireless control indicator will flash quickly which means the user can do the next configuration.

Between wireless control network function and wire controller function, you can only choose one.

Electric heating function (some models):

When the air conditioner switches to heating mode, the electrical heating feature is activated automatically. It can be stopped or started again by remote controller.

NOTE: This function can only be activated by remote controller.

Safety Precautions

- Contact an authorized service technician for repair or maintenance. Improper repair and maintenance may cause water leakage, electrical shock, or fire, and may void your warranty.
- **DO NOT** substitute a blown fuse with a fuse that has a higher or lower amperage rating, as this may damage the circuit or cause an electrical fire.
- Make sure the drain hose is set up according to the instructions. Failure to do so could cause leakage and result in personal property damage, fire and electric shock.
- Make sure that all wires are connected properly. Failure to connect wires according to instructions can result in electrical shock or fire.

Unit Maintenance

BEFORE CLEANING OR MAINTENANCE

- Always turn off your air conditioning system and disconnect its power supply before cleaning or maintenance.
- **DO NOT** use chemicals or chemically treated cloths to clean the unit.
- **DO NOT** use benzene, paint thinner, polishing powder or other solvents to clean the unit. They can cause the plastic surface to crack or deform.
- **DO NOT** wash the unit under running water. Doing so causes electrical danger.
- **DO NOT** use water hotter than 40°C (104°F) to clean the front panel. This can cause the panel to deform or become discolored.
- Clean the unit using a damp, lint-free cloth and neutral detergent. Dry the unit with a dry, lint-free cloth.

How To Clean The Air Filter

The filter prevents dust and other particles from entering the indoor unit. Dust buildup can reduce the efficiency of the air conditioner. For optimum efficiency, clean the air filter every two weeks or more frequently if you live in a dusty area. Replace the filter with a new one if it's heavily clogged and cannot be cleaned.

WARNING: DO NOT REMOVE OR CLEAN THE FILTER BY YOURSELF

Removing and cleaning the filter can be dangerous. Removal and maintenance must be performed by a certified technician.

NOTE: In households with animals, you will have to periodically wipe down the grille to prevent animal hair blocking airflow.

Cleaning the dust filter located at the bottom of the unit:

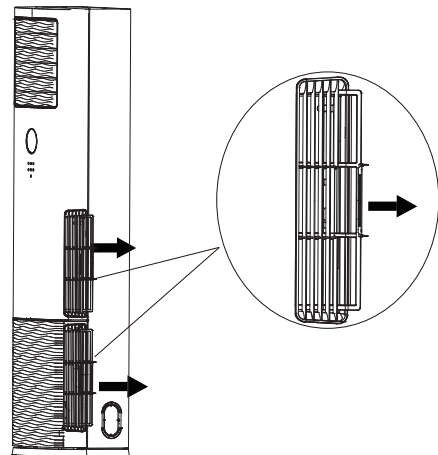

Fig. 4.1

Seize the left and right at the bottom of the strainer mesh put his hand to pull, remove the strainer mesh. Place the strainer mesh clean, dry in the shade. Packed strainer mesh .

4. Remove the air filter.
5. Clean the air filter by vacuuming the surface or washing it in warm water with mild detergent.
 - A. If using a vacuum cleaner, the inlet side should face the vacuum.

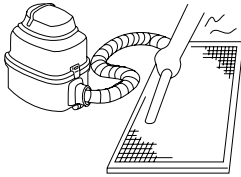

Fig. 4.2

- B. If using water, the inlet side should face down and away from the water stream.

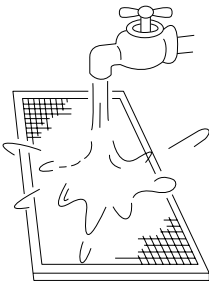

Fig. 4.3

6. Rinse the filter with clean water and allow it to air-dry. **DO NOT** let the filter dry in direct sunlight.
7. Reinstall the filter.

Repairing Refrigerant Leaks

WARNING

- If the refrigerant leaks, turn off the air conditioner and any combustible heating devices, ventilate the room and call your dealer immediately. Refrigerant is both toxic and flammable. **DO NOT** use the air conditioner until the leak is repaired.
- When the air conditioner is installed in a small room, measures must be taken to prevent the refrigerant concentration from exceeding the safety limit in the event of refrigerant leakage. Concentrated refrigerant causes a severe health and safety threat.

Refrigerant Leak Detection System (some models)

- In the event of a refrigerant leak, the LCD screen will display "EC" and the LED indicator light will flash.

Preparation For Periods Of Non-Use

Maintenance after Extended Non-Use

1. Remove any obstacles blocking the vents of both the indoor and outdoor units.
2. Clean the air filter and the front grille of the indoor unit. Reinstall the clean, dry air filter in its original position.
3. Turn on the main power switch at least 12 hours prior to operating the unit.

Storing the Unit While Not In Use

1. Run the appliance on FAN mode for 12 hours in a warm room to dry it and prevent mold.
2. Turn off the appliance and unplug it.
3. Clean the air filter according to the instructions in the previous section. Reinstall the clean, dry filter before storing.
4. Remove the batteries from the remote control.

Troubleshooting

5

CAUTIONS

If one of the following conditions occurs, switch off the power supply immediately and contact your dealer for further assistance.

- The operation light continues to flash rapidly after the unit has been restarted.
- The remote control buttons do not work.
- The unit continually trips fuses or circuit breakers.
- A foreign object or water enters the air conditioner.
- Other abnormal situations.

Common Problems

The following symptoms are not a malfunction and in most situations will not require repairs.

Problem	Possible Causes
Unit does not turn on when pressing ON/OFF button	The unit has a 3-minute protection feature that prevents the unit from overloading. The unit cannot be restarted within three minutes of being turned off.
The unit changes from COOL mode to FAN mode	The unit changes its setting to prevent frost from forming on the unit. Once the temperature increases, the unit will start operating again.
	The set temperature has been reached, at which point the unit turns off the compressor. The unit will resume operating when the temperature fluctuates again.
The indoor unit emits white mist	In humid regions, a large temperature difference between the room's air and the conditioned air can cause white mist.
Both the indoor and outdoor units emit white mist	When the unit restarts in HEAT mode after defrosting, white mist may be emitted due to moisture generated from the defrosting process.
	A squeaking sound is heard when the system is OFF or in COOL mode. The noise is also heard when the drain pump (optional) is in operation.
The indoor unit makes noises	A squeaking sound may occur after running the unit in HEAT mode due to expansion and contraction of the unit's plastic parts.
	A low hissing sound may occur during operation. This is normal and is caused by refrigerant gas flowing through both the indoor and outdoor units.
Both the indoor unit and outdoor unit make noises	A low hissing sound may be heard when the system starts, has just stopped running or is defrosting. This noise is normal and is caused by the refrigerant gas stopping or changing direction.
The outdoor unit makes noises	The unit will make different sounds based on its current operating mode.

Problem	Possible Causes
Dust is emitted from either the indoor or outdoor unit	The unit may accumulate dust during extended periods of non-use, which will be emitted when the unit is turned on. This can be mitigated by covering the unit during long periods of inactivity.
The unit emits a bad odor	The unit may absorb odors from the environment (such as furniture, cooking, cigarettes, etc.) which will be emitted during operations.
	The unit's filters have become moldy and should be cleaned.
The fan of the outdoor unit does not operate	During operation, the fan speed is controlled to optimize product operation.

Troubleshooting Tips

When troubles occur, please check the following points before contacting a repair company.

Problem	Possible Causes	Solution
The unit is not working	Power failure	Wait for the power to be restored
	The power switch is off	Turn on the power
	The fuse is burned out	Replace the fuse
	Remote control batteries are dead	Replace the remote control batteries
	The unit's 3-minute protection has been activated	Wait three minutes after restarting the unit
Poor cooling performance	Temperature setting may be higher than the ambient room temperature	Lower the temperature setting
	The heat exchanger on the indoor or outdoor unit is dirty	Clean the affected heat exchanger
	The air filter is dirty	Remove the filter and clean it according to instructions
	The air inlet or outlet of either unit is blocked	Turn the unit off, remove the obstruction and turn it back on
	Doors and windows are open	Make sure that all doors and windows are closed while operating the unit
	Excessive heat is generated by sunlight	Close windows and curtains during periods of high heat or bright sunshine
	Low refrigerant due to leak or long-term use	Check for leaks, re-seal if necessary and top off refrigerant
The unit starts and stops frequently	There's too much or too little refrigerant in the system	Check for leaks and recharge the system with refrigerant
	There is air, incompressible gas or foreign material in the refrigeration system.	Evacuate and recharge the system with refrigerant
	System circuit is blocked	Determine which circuit is blocked and replace the malfunctioning piece of equipment
	The compressor is broken	Replace the compressor
	The voltage is too high or too low	Install a manostat to regulate the voltage
Poor heating performance	The outdoor temperature is lower than 7°C (44.5°F)	Check for leaks and recharge the system with refrigerant
	Cold air is entering through doors and windows	Make sure that all doors and windows are closed during use
	Low refrigerant due to leak or long-term use	Check for leaks, re-seal if necessary and top off refrigerant

Error Codes



· Inverter Split Type

Number	Cause	Error Code
1	Indoor EEPROM error	E0
2	Indoor and outdoor communication failure	E1
3	Indoor fan speed malfunction	E3
4	Indoor room temperature sensor open circuit or short circuit	E4
5	Evaporator coil temperature sensor open circuit or short circuit	E5
6	Refrigerant leakage detection malfunction	EC
7	Communication malfunction between two indoor units (for twins model)	E8
8	Other malfunction of twins model	E9
9	Display board and main control communication failure	Eb
10	Outdoor unit malfunction	Ed
11	Current overload protection	F0
12	Outdoor room temperature sensor open circuit or short circuit	F1
13	Outdoor condenser pipe temperature sensor error	F2
14	Discharging air temperature sensor error	F3
15	Outdoor EEPROM error	F4
16	Outdoor fan speed malfunction	F5
17	T2b sensor error	F6
18	Inverter module IPM protection	P0
19	High/Low voltage protection	P1
20	Compressor top overheating protection	P2
21	Outdoor low temp. Protection	P3
22	Compressor drive error	P4
23	Compressor High/Low-pressure protection	P6
24	Outdoor IGBT sensor error	P7



· Fixed-speed Type













Number	Cause	Error Code
1	Indoor EEPROM error	E0
2	Indoor and outdoor communication failure	E1
3	Dc fan stall failure	E3
4	T1sensor error	E4
5	T2sensor error	E5
6	Display board and main control communication failure	E6
7	Refrigerant leakage fault	E7
8	The compressor low pressure failure	E8
9	T4sensor error	F1
10	T3sensor error	F2
11	Power failure or lack of phase phase sequence reverse fault	F5
12	Heating the cold wind off the indoor fan	P9
13	Compressor low voltage protection	P10
14	Compressor high pressure protection	P11
15	Compressor current overload protection	P12
16	The indoor evaporator protection closed compressor (high or low temperatures)	P13
17	Outdoor condenser heat protection compressor	P14
18	Outdoor high exhaust temperature closed compressor	P15
19	Frost	dF

Accessories

6

The air conditioning system comes with the following accessories. Use all of the installation parts and accessories to install the air conditioner. Improper installation may result in water leakage, electrical shock and fire, or equipment failure.

Accessories

	Name	Shape	Quantity
Indoor unit installation	Self-tapping screw 3.9x25		2
	Flat washers		2
	Bushing-sleeve cover		1
Refrigeration Fittings	Soundproof/insulation sheath (some models)		2
Drainpipe Fittings	Drain hose (some models)		1
	Band (some models)		2
	Drain joint (some models)		1
	Seal ring (some models)		1
Installation Accessory (some models)	Connection cables		1
	Putty		1
	Rodent-proof mesh		1
	Self-tapping screw ST3.9x12		1
Remote controller & Its Frame (some models)	Remote controller		1
	Fixing screw for remote controller holder ST2.9 x 10		2
	Remote controller holder		1
	Dry battery AAA		2
	Remote controller illustration		1
	Owner's manual		1
	Installation manual		1
	Refrigerant Pipe (optional)		1

Installation Overview

7

INSTALLATION ORDER

1



Install the indoor unit
(Page 22)

2

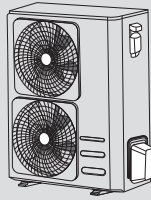

Install the outdoor unit
(Page 26)

3

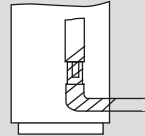

Install the drainpipe
(Page 29)

4

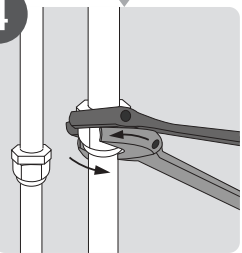

Connect the refrigerant pipes
(Page 30)

5

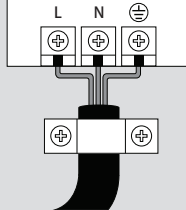

Connect the wires
(Page 33)

6

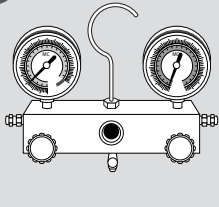

Evacuate the refrigeration system
(Page 35)

7

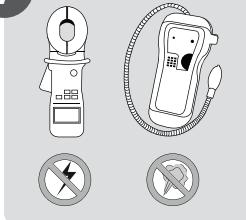

Perform a test run
(Page 37)

Unit installation
Overview

Indoor Unit Parts

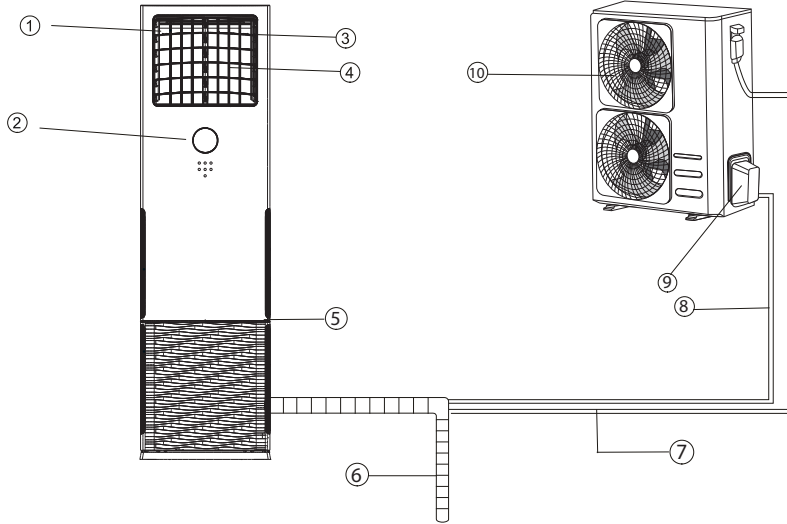

Fig. 8.1

Indoor unit

- ① Air outlet
- ② Operation panel
- ③ Horizontal airflow control louver
- ④ Vertical airflow control louver
- ⑤ Air inlet(2 sides)

Outdoor unit

- ⑥ Drain pipe, vent pipe
- ⑦ Connection cable
- ⑧ Connection pipe
- ⑨ Refrigerant pipe port
- ⑩ Air outlet

NOTE ON ILLUSTRATIONS

Illustrations in this manual are for explanatory purposes. The actual shape of your indoor unit may be slightly different. The actual shape shall prevail.

Indoor Unit Installation Instructions

PRIOR TO INSTALLATION

Before installing the indoor unit, refer to the label on the product box to make sure that the model number of the indoor unit matches the model number of the outdoor unit.

Step 1: Select installation location

Before installing the indoor unit, you must choose an appropriate location. The following are standards that will help you choose an appropriate location for the unit.

Proper installation locations meet the following standards:

- ☑ Good air circulation
- ☑ Convenient drainage
- ☑ Positioned such that noise from the unit will not disturb other people
- ☑ Firm and solid—the location will not vibrate
- ☑ Strong enough to support the weight of the unit
- ☑ Positioned at least one meter from all other electrical devices (e.g. TV, radio, computer)

Refer to the following diagram to ensure proper distance from walls and ceiling:

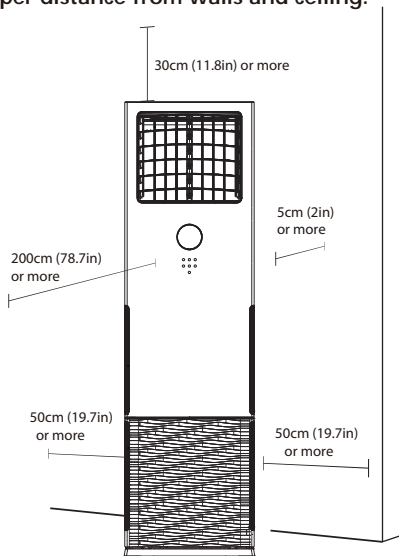

Fig. 8.2

DO NOT install unit in the following locations:

- ⊗ Near any source of heat, steam, or combustible gas
- ⊗ Near flammable items such as curtains or clothing
- ⊗ Near any obstacle that might block air circulation
- ⊗ Near the doorway
- ⊗ In a location subject to direct sunlight

NOTE ABOUT WALL HOLE:

If there is no fixed refrigerant piping: When choosing a location, be aware that you should leave ample room for a hole in the wall (see the step “Drill wall hole for connective piping”) for the signal cable and refrigerant piping that connect the indoor and outdoor units. The default position for all piping is the right side of the indoor unit (while facing the unit). However, the unit can accommodate piping to both the left or the right.

Indoor Unit
Installation

Indoor Unit Mounting Dimensions

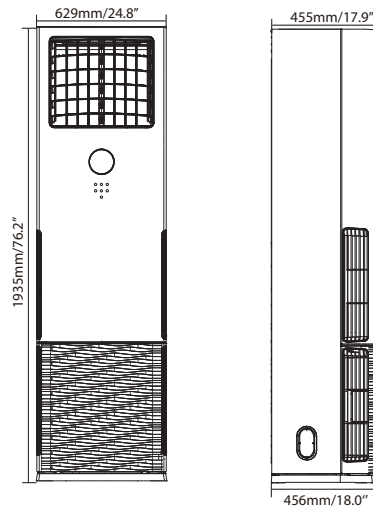

Fig. 8.3

Step 2: Unfastening the operation panel and detaching the filter

1. Open the packaging and take out the indoor unit. Remove the protective tape and any components.
2. Open the two boxes for storing the remote control found on either side of the indoor unit, then undo the screws on the operation panel.
3. Use both hands to gently hold the decorative part at the top of the operation panel, then lift it upwards to remove it along with the wire terminal which is connected to it.
4. Undo the two screws on the front of the filter.
5. Use both hands to hold the two sunken areas on either side of the filter and pull away from the unit. Lift the filter upwards to remove it.
6. Please take off the air-inlet grid before connecting the pipes/wires.

First remove the screws cover, then remove the screws on the air-inlet grid, then take off the grid. (See Fig. 8.4)

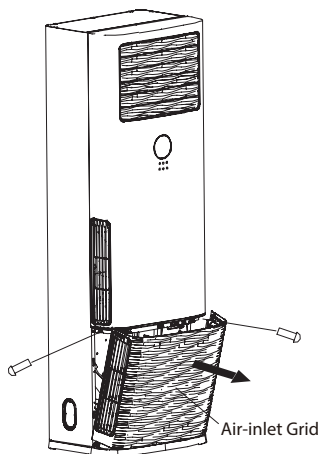

Fig. 8.4

7. Remove all of the accessories placed inside the bottom cavity of the indoor unit.
8. Check that all of the accessories match those found on the "Installation Diagrams and Accessories" as shown on the previous page.

Step 3. Remove the fasteners from the roller (only found on selected models)

1. Check to see whether the roller on the indoor unit has any fasteners holding it in place and tear off the notice sticker.
2. Remove the fasteners from the roller according to the directions on the sticker.

Step 4. Fastening the indoor unit (to prevent it from falling down)

1. Measure the position of the holes for installation.
2. Insert the M8 bolts into the unit while it is on the floor (the amount of bolts used depends on the number of holes on the unit's chassis). (See Fig. 8.5)
3. Lift up the indoor unit so that the installation holes cover the bolts, then fasten the nuts onto the bolts and tighten them.

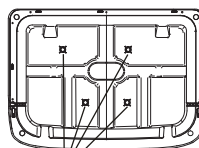

Fig. 8.5

⚠ CAUTION

If further support is needed to prevent the unit from falling down, a protective wedge can be installed. The installation procedure for this wedge is as follows:

- Take out the protective wedge and measure the correct size.
- Use the self-tapping screws to fasten the protective wedge to the top cover of the indoor unit.
- Fasten the other end of the wedge tightly to the wall using the self-tapping screws.

Step 5. Installing the rodent-proof mesh

1. Remove the metal rodent-proof mesh from the piping found on the unit by gently tapping on it.

- Use a knife to cut a small hole by following the markings on the ratproof board. (See Fig. 8.6)
- Insert the ratproof board into the unit and hold it in place tightly.

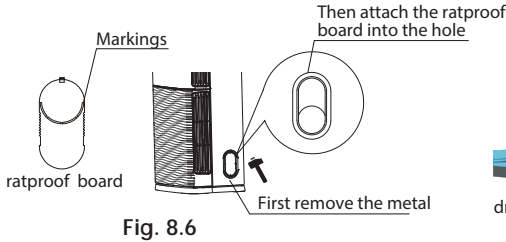

Pipe/wire-hole position on back side

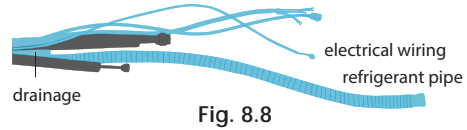
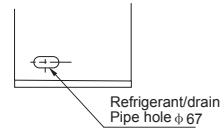

Step 6. Piping and binding

- Lay the connecting piping flat on the ground. Place the drainage hose, refrigerant pipe, and all electrical wiring (making sure that both ends are arranged correctly) next to the piping.
- Using the drainage hose as a guide, measure and adjust the length of the low voltage wiring, high voltage wiring, any other electrical wiring, and refrigerant pipe. Use cable ties to initially fasten them in place.
- Arrange the piping so that the drainage hose is on the bottom, the connecting piping is in the middle, and the electrical wiring is at the top.
- Use adhesive vinyl tape to begin binding the piping together. Start binding the tape at the bottom end of the drainage hose, and make sure that the connectors are secured tightly. Pipe/wire-hole positions on both sides

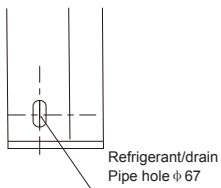

Pipe/wire-hole position on the bottom

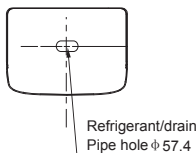

CAUTION

The electrical wiring, drainage hose, and refrigerant pipe must exit the binding in a suitable place. All binding must be mutually connected, evenly applied, and aesthetically pleasing.

NOTE

- Only models with a ventilation function contain ventilation ducting.
- The amount and type of electrical wiring used may vary according to the specific model.
- The ends of the ventilation ducting and electrical wiring are different, please check carefully before starting to bind.

Step 7: Applying the sealant putty and installing the wall hole cover

- Tidy up the already bound piping.
- Evenly apply the sealant putty to the gaps between the piping and the wall, then press on the putty firmly.
- Pull the wall hole cover apart to open it. After fastening tightly to the piping, push it into the hole in the wall to securely fasten it to the wall and complete the installation.

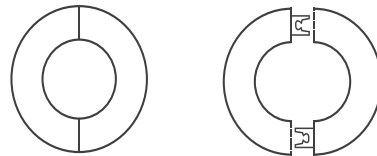

Outdoor Unit Installation

9

Outdoor Unit Installation Instructions

Step 1: Select installation location.

The outdoor unit should be installed in the location that meets the following requirements:

- ❑ Place the outdoor unit as close to the indoor unit as possible.
- ❑ Ensure that there is enough room for installation and maintenance.
- ❑ The air inlet and outlet must not be obstructed or exposed to strong wind.
- ❑ Ensure the location of the unit will not be subject to snowdrifts, accumulation of leaves or other seasonal debris. If possible, provide an awning for the unit. Ensure the awning does not obstruct airflow.
- ❑ The installation area must be dry and well ventilated.
- ❑ There must be enough room to install the connecting pipes and cables and to access them for maintenance.
- ❑ The area must be free of combustible gases and chemicals.
- ❑ The pipe length between the outdoor and indoor unit may not exceed the maximum allowable pipe length.
- ❑ If possible, **DO NOT** install the unit where it is exposed to direct sunlight.
- ❑ If possible, make sure the unit is located far away from your neighbors' property so that the noise from the unit will not disturb them.
- ❑ If the location is exposed to strong winds (for example: near a seaside), the unit must be placed against the wall to shelter it from the wind. If necessary, use an awning. (See Fig. 9.1 & 9.2)
- ❑ Install the indoor and outdoor units, cables and wires at least 1 meter from televisions or radios to prevent static or image distortion. Depending on the radio waves, a 1 meter distance may not be enough to eliminate all interference.

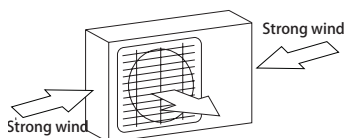

Fig. 9.1

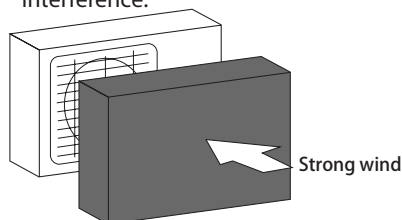

Fig. 9.2

Step 2: Install outdoor unit.

Fix the outdoor unit with anchor bolts (M10)

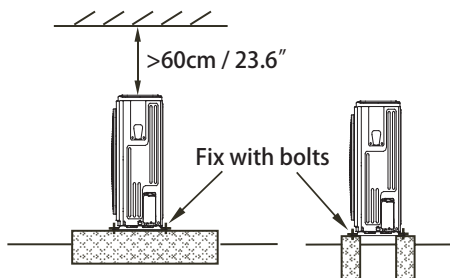

Fig. 9.3

CAUTION

- Be sure to remove any obstacles that may block air circulation.
- Make sure you refer to Length Specifications to ensure there is enough room for installation and maintenance.

Outdoor Unit Mounting Dimensions

The mounting dimensions vary among different outdoor units. The fixing bolt head diameter should be more than 12mm.

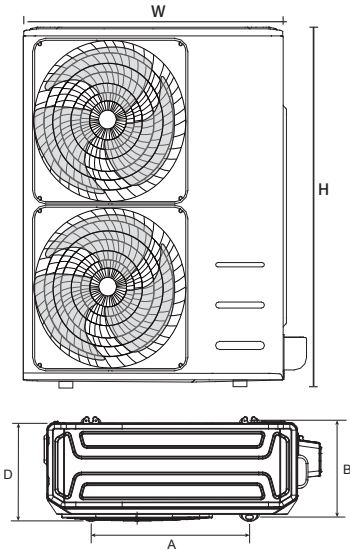

Fig. 9.3

Outdoor Unit Dimension (mm)			Mounting Dimension (mm)	
W	H	D	A	B
952	1333	415	634	404
900	1170	350	590	378

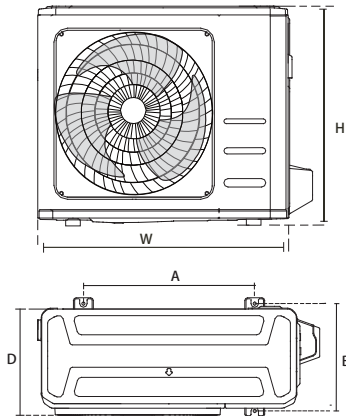

Fig. 9.4

Outdoor Unit Dimension (mm)			Mounting Dimension (mm)	
W	H	D	A	B
681	434	285	460	292
700	550	275	450	260
770	555	300	487	298
800	554	333	514	340
845	702	363	540	350
946	810	420	673	403

NOTE: The minimum distance between the outdoor unit and walls described in the installation guide does not apply to airtight rooms. Be sure to keep the unit unobstructed in at least two of the three directions (M, N, P) (See Fig. 9.5)

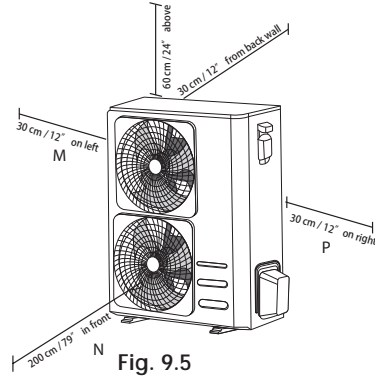

Fig. 9.5

Outdoor Unit Installation

Rows of series installation

The relations between H, A and L are as follows.

	L	A
$L \leq H$	$L \leq 1/2H$	25 cm / 9.8" or more
	$1/2H < L \leq H$	30 cm / 11.8" or more
$L > H$	Can not be installed	

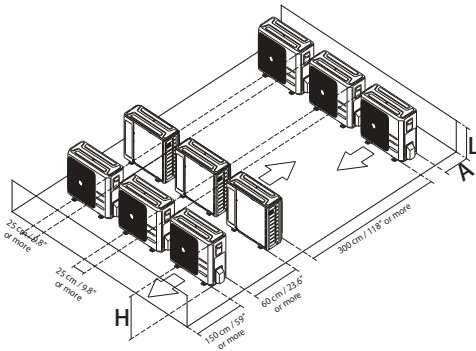

Fig. 9.6

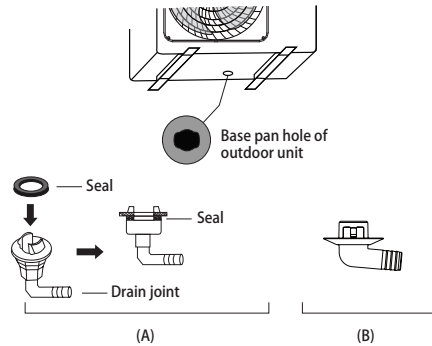

Fig. 9.7

Drain Joint Installation

If the drain joint comes with a rubber seal (see Fig. 9.7 - A), do the following:

1. Fit the rubber seal on the end of the drain joint that will connect to the outdoor unit.
2. Insert the drain joint into the hole in the base pan of the unit.
3. Rotate the drain joint 90° until it clicks in place facing the front of the unit.
4. Connect a drain hose extension (not included) to the drain joint to redirect water from the unit during heating mode.

If the drain joint doesn't come with a rubber seal (see Fig. 9.7 - B), do the following:

1. Insert the drain joint into the hole in the base pan of the unit. The drain joint will click in place.
2. Connect a drain hose extension (not included) to the drain joint to redirect water from the unit during heating mode.

NOTE: Make sure the water drains to a safe location where it will not cause water damage or a slipping hazard.

Notes On Drilling Hole In Wall

You must drill a hole in the wall for the refrigerant piping, and the signal cable that will connect the indoor and outdoor units.

1. Determine the location of the wall hole based on the location of the outdoor unit.
2. Using a 65-mm (2.5") core drill, drill a hole in the wall.

NOTE: When drilling the wall hole, make sure to avoid wires, plumbing, and other sensitive components.

3. Place the protective wall cuff in the hole. This protects the edges of the hole and will help seal it when you finish the installation process.

Drainpipe Installation

10

The drainpipe is used to drain water from the unit. Improper installation may cause unit and property damage.

⚠ CAUTION

- Insulate all piping to prevent condensation, which could lead to water damage.
- If the drainpipe is bent or installed incorrectly, water may leak and cause a malfunction of the water-level switch.
- In HEAT mode, the outdoor unit will discharge water. Ensure that the drain hose is placed in an appropriate area to avoid water damage and slippage due to frozen drain water.
- **DO NOT** pull the drainpipe forcefully as this could cause it to disconnect.

NOTE ON PURCHASING PIPES

This installation requires a polyethylene tube (outside diameter = 3.7-3.9cm, inside diameter = 3.2cm), which can be obtained at your local hardware store or from your dealer.

Indoor Drainpipe Installation

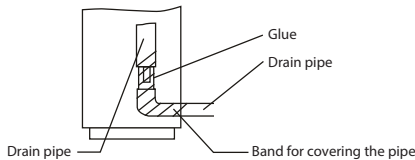

Fig. 10.1

1. Make sure the drain pipe is connected to the outdoor side downward.
2. The hard polyvinyl chloride(PVC)plastic pipe (external diameter 26 mm) sold in the market is suitable for the attached soft drain pipe.
3. Please connect the Soft Drain Pipe with the Drain Pipe, then fix it with band; if you have to connect the Drain Pipe indoors, to avoid condensing caused by air intake, you must cover the pipe with heat-insulation material (polyethylene with Specific Gravity of 0.03, at least 9 mm in thickness), and use Glue Band to fix it.

4. After the Drain Pipe has been connected, please check if the water drains out of the pipe efficiently and has no leakage.
5. Refrigerant Pipe and Drain Pipe should be heat-insulated to avoid condensing and water-dropping later on.
6. Using a 65-mm (2.5") core drill, drill a hole in the wall. Make sure that the hole is drilled at a slight downward angle, so that the outdoor end of the hole is lower than the indoor end by about 1cm (0.4"). This will ensure proper water drainage (See Fig. 10.2). Place the protective wall cuff in the hole. This protects the edges of the hole and will help seal it when you finish the installation process.

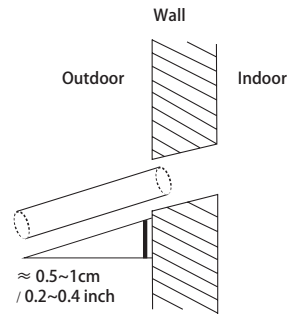

Fig. 10.2

NOTE: When drilling the wall hole, make sure to avoid wires, plumbing, and other sensitive components.

7. Pass the drain hose through the wall hole. Make sure the water drains to a safe location where it will not cause water damage or a slipping hazard.

NOTE: The drainpipe outlet should be at least 5cm (1.9") above the ground. If it touches the ground, the unit may become blocked and malfunction. If you discharge the water directly into a sewer, make sure that the drain has a U or S pipe to catch odors that might otherwise come back into the house.

Refrigerant Piping Connection

11

Safety Precautions

⚠ WARNING

- All field piping must be completed by a licensed technician and must comply with the local and national regulations.
- When the air conditioner is installed in a small room, measures must be taken to prevent the refrigerant concentration in the room from exceeding the safety limit in the event of refrigerant leakage. If the refrigerant leaks and its concentration exceeds its proper limit, hazards due to lack of oxygen may result.
- When installing the refrigeration system, ensure that air, dust, moisture or foreign substances do not enter the refrigerant circuit. Contamination in the system may cause poor operating capacity, high pressure in the refrigeration cycle, explosion or injury.
- Ventilate the area immediately if there is refrigerant leakage during the installation. Leaked refrigerant gas is both toxic and flammable. Ensure there is no refrigerant leakage after completing the installation work.

Step1: Cut pipes

When preparing refrigerant pipes, take extra care to cut and flare them properly. This will ensure efficient operation and minimize the need for future maintenance.

1. Measure the distance between the indoor and outdoor units.
2. Using a pipe cutter, cut the pipe a little longer than the measured distance.

⚠ CAUTION

DO NOT deform pipe while cutting. Be extra careful not to damage, dent, or deform the pipe while cutting. This will drastically reduce the heating efficiency of the unit.

1. Make sure that the pipe is cut at a perfect 90° angle. Refer to Fig. 7.1 for examples of bad cuts

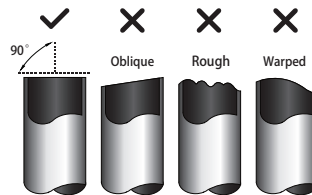

Fig. 11.1

Step 2: Remove burrs.

Burrs can affect the air-tight seal of refrigerant piping connection. They must be completely removed.

1. Hold the pipe at a downward angle to prevent burrs from falling into the pipe.
2. Using a reamer or deburring tool, remove all burrs from the cut section of the pipe.

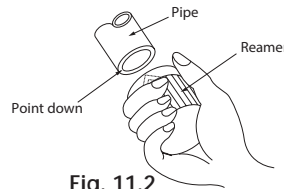

Fig. 11.2

Refrigerant Piping Connection Instructions

⚠ CAUTION

- The branching pipe must be installed horizontally. An angle of more than 10° may cause malfunction.
- **DO NOT** install the connecting pipe until both indoor and outdoor units have been installed.
- Insulate both the gas and liquid piping to prevent water leakage.

Step 3: Flare pipe ends

Proper flaring is essential to achieve an airtight seal.

1. After removing burrs from cut pipe, seal the ends with PVC tape to prevent foreign materials from entering the pipe.
2. Sheath the pipe with insulating material.
3. Place flare nuts on both ends of pipe. Make sure they are facing in the right direction, because you can't put them on or change their direction after flaring. See Fig. 11.3

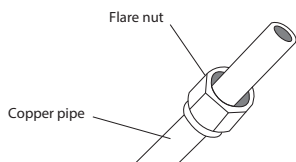

Fig. 11.3

4. Remove PVC tape from ends of pipe when ready to perform flaring work.
5. Clamp flare form on the end of the pipe. The end of the pipe must extend beyond the flare form.

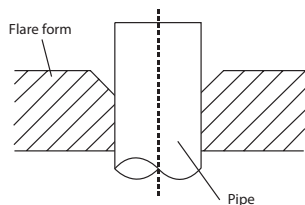

Fig. 11.4

6. Place flaring tool onto the form.
7. Turn the handle of the flaring tool clockwise until the pipe is fully flared. Flare the pipe in accordance with the dimensions shown in table 11.1.

Table 11.1: PIPING EXTENSION BEYOND FLARE FORM

Pipe gauge	Tightening torque	Flare dimension (A) (Unit: mm/Inch)		Flare shape
		Min.	Max.	
Ø 6.4	18-20 N.m (183-204 kgf.cm)	8.4/0.33	8.7/0.34	
Ø 9.5	25-26 N.m (255-265 kgf.cm)	13.2/0.52	13.5/0.53	
Ø 12.7	35-36 N.m (357-367 kgf.cm)	16.2/0.64	16.5/0.65	
Ø 15.9	45-47 N.m (459-480 kgf.cm)	19.2/0.76	19.7/0.78	
Ø 19.1	65-67 N.m (663-683 kgf.cm)	23.2/0.91	23.7/0.93	
Ø 22	75-85 N.m (765-867 kgf.cm)	26.4/1.04	26.9/1.06	

Fig. 11.5

8. Remove the flaring tool and flare form, then inspect the end of the pipe for cracks and even flaring.

Step 4: Connect pipes

Connect the copper pipes to the indoor unit first, then connect it to the outdoor unit. You should first connect the low-pressure pipe, then the high-pressure pipe.

1. When connecting the flare nuts, apply a thin coat of refrigeration oil to the flared ends of the pipes.
2. Align the center of the two pipes that you will connect.

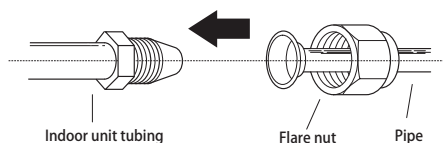

Fig. 11.6

3. Tighten the flare nut as tightly as possible by hand.
4. Using a spanner, grip the nut on the unit tubing.
5. While firmly gripping the nut, use a torque wrench to tighten the flare nut according to the torque values in table 11.1.

NOTE: Use both a spanner and a torque wrench when connecting or disconnecting pipes to/from the unit.

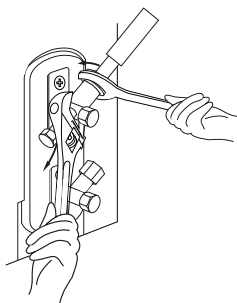

Fig. 11.7

⚠ CAUTION

- Ensure to wrap insulation around the piping. Direct contact with the bare piping may result in burns or frostbite.
- Make sure the pipe is properly connected. Over tightening may damage the bell mouth and under tightening may lead to leakage.

NOTES ON MINIMUM BEND RADIUS

Carefully bend the tubing in the middle according to the diagram below. **DO NOT** bend the tubing more than 90° or more than 3 times.

Bend the pipe with thumb



min-radius 10cm (3.9")

Fig. 11.8

6. After connecting the copper pipes to the indoor unit, wrap the power cable, signal cable and the piping together with binding tape.

NOTE: **DO NOT** intertwine signal cable with other wires. While bundling these items together, do not intertwine or cross the signal cable with any other wiring.

7. Thread this pipeline through the wall and connect it to the outdoor unit.
8. Insulate all the piping, including the valves of the outdoor unit.
9. Open the stop valves of the outdoor unit to start the flow of the refrigerant between the indoor and outdoor unit.

⚠ CAUTION

Check to make sure there is no refrigerant leak after completing the installation work. If there is a refrigerant leak, ventilate the area immediately and evacuate the system (refer to the Air Evacuation section of this manual).

Safety Precautions

WARNING

- Be sure to disconnect the power supply before working on the unit.
- All electrical wiring must be done according to local and national regulations.
- Electrical wiring must be done by a qualified technician. Improper connections may cause electrical malfunction, injury and fire.
- An independent circuit and single outlet must be used for this unit. **DO NOT** plug another appliance or charger into the same outlet. If the electrical circuit capacity is not enough or there is a defect in the electrical work, it can lead to shock, fire, unit and property damage.
- Connect the power cable to the terminals and fasten it with a clamp. An insecure connection may cause fire.
- Make sure that all wiring is done correctly and the control board cover is properly installed. Failure to do so can cause overheating at the connection points, fire, and electrical shock.
- Ensure that main supply connection is made through a switch that disconnects all poles, with contact gap of a least 3mm (0.118").
- **DO NOT** modify the length of the power cord or use an extension cord.

CAUTION

- Connect the outdoor wires before connecting the indoor wires.
- Make sure you ground the unit. The grounding wire should be away from gas pipes, water pipes, lightning rods, telephone or other grounding wires. Improper grounding may cause electrical shock.
- **DO NOT** connect the unit with the power source until all wiring and piping is completed.
- Make sure that you do not cross your electrical wiring with your signal wiring, as this can cause distortion and interference.

Follow these instructions to prevent distortion when the compressor starts:

- The unit must be connected to the main outlet. Normally, the power supply must have a low output impedance of 32 ohms.
- No other equipment should be connected to the same power circuit.
- The unit's power information can be found on the rating sticker on the product.

TAKE NOTE OF FUSE SPECIFICATIONS

The air conditioner's circuit board(PCB) is designed with a fuse to provide overcurrent protection. The specifications of the fuse are printed on the circuit board, such as:

Indoor unit: T5A/250VAC, T10A/250VAC.

(applicable for unit adopts R32 or R290 refrigerant only)

Outdoor unit: T20A/250VAC(for <24000Btu/h unit), T30A/250VAC(for >24000Btu/h unit)

Outdoor Unit Wiring

WARNING

Before performing any electrical or wiring work, turn off the main power to the system.

1. Prepare the cable for connection
 - a. You must first choose the right cable size before preparing it for connection. Be sure to use H07RN-F cables.

Table 12.1: Minimum Cross-Sectional Area of Power and Signal Cables in North America

Rated Current of Appliance (A)	AWG
≤ 7	18
7 - 13	16
13 - 18	14
18 - 25	12
25 - 30	10

Table 12.2: Other World Regions

Rated Current of Appliance (A)	Nominal Cross-Sectional Area (mm ²)
≤ 6	0.75
6 - 10	1
10 - 16	1.5
16 - 25	2.5
25 - 32	4
32 - 45	6

- b. Using wire strippers, strip the rubber jacket from both ends of the signal cable to reveal approximately 15cm (5.9") of wire.
- c. Strip the insulation from the ends.
- d. Using a wire crimper, crimp u-lugs on the ends.

NOTE: When connecting the wires, strictly follow the wiring diagram found inside the electrical box cover.

2. Remove the electric cover of the outdoor unit. (See Fig. 12.1)

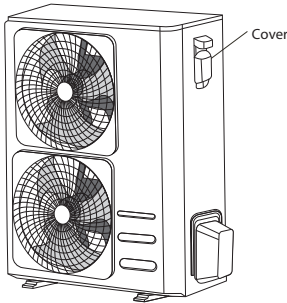

Fig. 12.1

3. Connect the u-lugs to the terminals
Match the wire colors/labels with the labels on the terminal block, Firmly screw the u-lug of each wire to its corresponding terminal.
4. Clamp down the cable with the cable clamp.
5. Insulate unused wires with electrical tape.
Keep them away from any electrical or metal parts.
6. Reinstall the cover of the electric control box.

Indoor Unit Wiring

1. Prepare the cable for connection
 - a. Using wire strippers, strip the rubber jacket from both ends of the signal cable to reveal about 15cm (5.9") of the wire.
 - b. Strip the insulation from the ends of the wires.
 - c. Using a wire crimper, crimp the u-lugs to the ends of the wires.
2. Undo the screw on the cover of the electric control box and remove the cover.
3. Connect the u-lugs to the terminals.
Match the wire colors/labels with the labels on the terminal block, Firmly screw the u-lug of each wire to its corresponding terminal. Refer to the Serial Number and Wiring Diagram located on the cover of the electric control box.

⚠ CAUTION

- While connecting the wires, please strictly follow the wiring diagram.
 - The refrigerant circuit can become very hot. Keep the interconnection cable away from the copper tube.
4. Clamp down the cable with the cable clamp. The cable must not be loose or pull on the u-lugs.
 5. Reattach the electric box cover.

接线示意图

Air Evacuation

13

Safety Precautions

⚠ CAUTION

- Use a vacuum pump with a gauge reading lower than -0.1MPa and an air discharge capacity above $40\text{L}/\text{min}$.
- The outdoor unit does not need vacuuming. **DO NOT** open the outdoor unit's gas and liquid stop valves.
- Ensure that the Compound Meter reads -0.1MPa or below after 2 hours. If after three hours of operation and the gauge reading is still above -0.1MPa , check if there is a gas leak or water inside the pipe. If there is no leakage, perform another evacuation for 1 or 2 hours.
- **DO NOT** use refrigerant gas to evacuate the system.

Evacuation Instructions

Before using manifold gauge and vacuum pump, read their operation manuals to familiarize yourself with how to use them properly.

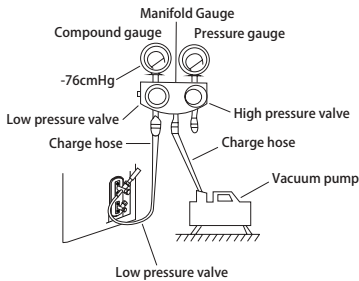

Fig. 13.1

1. Connect the charge hose of the manifold gauge to service port on the outdoor unit's low pressure valve.
2. Connect another charge hose from the manifold gauge to the vacuum pump.
3. Open the Low Pressure side of the manifold gauge. Keep the High Pressure side closed.

4. Turn on the vacuum pump to evacuate the system.
5. Run the vacuum for at least 15 minutes, or until the Compound Meter reads -76cmHg ($-1 \times 105\text{Pa}$).
6. Close the Low Pressure side of the manifold gauge, and turn off the vacuum pump.
7. Wait for 5 minutes, then check that there has been no change in system pressure.

NOTE: If there is no change in system pressure, unscrew the cap from the packed valve (high pressure valve). If there is a change in system pressure, there may be a gas leak.

8. Insert hexagonal wrench into the packed valve (high pressure valve) and open the valve by turning the wrench in a $1/4$ counterclockwise turn. Listen for gas to exit the system, then close the valve after 5 seconds.

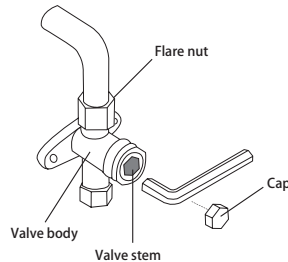

Fig. 13.2

9. Watch the Pressure Gauge for one minute to make sure that there is no change in pressure. The Pressure Gauge should read slightly higher than atmospheric pressure.
10. Remove the charge hose from the service port.
11. Using hexagonal wrench, fully open both the high pressure and low pressure valves.

OPEN VALVE STEMS GENTLY

When opening valve stems, turn the hexagonal wrench until it hits against the stopper. **DO NOT** try to force the valve to open further.

12. Tighten valve caps by hand, then tighten it using the proper tool.

Note On Adding Refrigerant

CAUTION

- Refrigerant charging must be performed after wiring, vacuuming, and the leak testing.
- **DO NOT** exceed the maximum allowable quantity of refrigerant or overcharge the system. Doing so can damage the unit or impact its functioning.
- Charging with unsuitable substances may cause explosions or accidents. Ensure that the appropriate refrigerant is used.
- Refrigerant containers must be opened slowly. Always use protective gear when charging the system.
- **DO NOT** mix refrigerants types.
- For the R290 or R32 refrigerant model, make sure the conditions within the area have been made safe by control of flammable material when the refrigerant added into air conditioner.

Some systems require additional charging depending on pipe lengths. The standard pipe length varies according to local regulations. For example, in North America, the standard pipe length is 7.5m (25') In other areas, the standard pipe length is 5m (16'). The additional refrigerant to be charged can be calculated using the following formula:

Liquid Side Diameter

	φ6.35(1/4")	φ9.52(3/8")	φ12.7(1/2")
R22 (orifice tube in the indoor unit):	(Total pipe length - standard pipe length) x 30g (0.32oz)/m(ft)	(Total pipe length - standard pipe length) x 65g(0.69oz)/m(ft)	(Total pipe length - standard pipe length) x 115g(1.23oz)/m(ft)
R22 (orifice tube in the outdoor unit):	(Total pipe length - standard pipe length) x 15g(0.16oz)/m(ft)	(Total pipe length - standard pipe length) x 30(0.32oz)/m(ft)	(Total pipe length - standard pipe length) x 60g(0.64oz)/m(ft)
R410A: (orifice tube in the indoor unit):	(Total pipe length - standard pipe length) x 30g(0.32oz)/m(ft)	(Total pipe length - standard pipe length) x 65g(0.69oz)/m(ft)	(Total pipe length - standard pipe length) x 115g(1.23oz)/m(ft)
R410A: (orifice tube in the outdoor unit):	(Total pipe length - standard pipe length) x 15g(0.16oz)/m(ft)	(Total pipe length - standard pipe length) x 30g(0.32oz)/m(ft)	(Total pipe length - standard pipe length) x 65g(0.69oz)/m(ft)
R32 :	(Total pipe length - standard pipe length) x 12g(0.13oz)/m(ft)	(Total pipe length - standard pipe length) x 24g(0.26oz)/m(ft)	(Total pipe length - standard pipe length) x 40g(0.42oz)/m(ft)

Before Test Run

A test run must be performed after the entire system has been completely installed. Confirm the following points before performing the test:

- a) The indoor and outdoor units are properly installed.
- b) Piping and wiring are properly connected.
- c) Ensure that there are no obstacles near the inlet and outlet of the unit that might cause poor performance or product malfunction.
- d) The refrigeration system does not leak.
- e) The drainage system is unimpeded and draining to a safe location.
- f) The heating insulation is properly installed.
- g) The grounding wires are properly connected.
- h) The length of the piping and the added refrigerant stow capacity have been recorded.
- i) The power voltage is the correct voltage for the air conditioner.

CAUTION

Failure to perform the test run may result in unit damage, property damage or personal injury.

Test Run Instructions

1. Open both the liquid and gas stop valves.
2. Turn on the main power switch and allow the unit to warm up.
3. Set the air conditioner to COOL mode.
4. For the Indoor Unit
 - a. Ensure the remote control and its buttons work properly.
 - b. Ensure the louvers move properly and can be changed using the remote control.
 - c. Double check to see if the room temperature is being registered correctly.
 - d. Ensure the indicators on the remote control and the display panel on the indoor unit work properly.
 - e. Ensure the manual buttons on the indoor unit works properly.

- f. Check to see that the drainage system is unimpeded and draining smoothly.
- g. Ensure there is no vibration or abnormal noise during operation.
5. For the Outdoor Unit
 - a. Check to see if the refrigeration system is leaking.
 - b. Make sure there is no vibration or abnormal noise during operation.
 - c. Ensure the wind, noise, and water generated by the unit do not disturb your neighbors or pose a safety hazard.
6. Drainage Test
 - a. Ensure the drainpipe flows smoothly. New buildings should perform this test before finishing the ceiling.
 - b. Remove the test cover. Add 2,000ml of water to the tank through the attached tube.
 - c. Turn on the main power switch and run the air conditioner in COOL mode.
 - d. Listen to the sound of the drain pump to see if it makes any unusual noises.
 - e. Check to see that the water is discharged. It may take up to one minute before the unit begins to drain depending on the drainpipe.
 - f. Make sure that there are no leaks in any of the piping.
 - g. Stop the air conditioner. Turn off the main power switch and reinstall the test cover.

NOTE: If the unit malfunctions or does not operate according to your expectations, please refer to the Troubleshooting section of the Owner's Manual before calling customer service.

European Disposal Guidelines

15

Users in European Countries may be required to properly dispose of this unit. This appliance contains refrigerant and other potentially hazardous materials. When disposing of this appliance, the law requires special collection and treatment. **DO NOT** dispose of this product as household waste or unsorted municipal waste.

When disposing of this appliance, you have the following options:

- Dispose of the appliance at designated municipal electronic waste collection facility.
- When buying a new appliance, the retailer will take back the old appliance free of charge.
- The manufacturer will also take back the old appliance free of charge.
- Sell the appliance to certified scrap metal dealers.

NOTE: Disposing of this appliance in the forest or other natural surroundings endangers your health and is bad for the environment. Hazardous substances may leak into the ground water and enter the food chain.

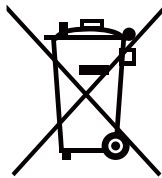

Information Servicing

(Required for the units adopt R32/R290 Refrigerant only)

16

1. Checks to the area

Prior to beginning work on systems containing flammable refrigerants, safety checks are necessary to ensure that the risk of ignition is minimised. For repair to the refrigerating system, the following precautions shall be complied with prior to conducting work on the system.

2. Work procedure

Works shall be undertaken under a controlled procedure so as to minimise the risk of a flammable gas or vapour being present while the work is being performed.

3. General work area

All maintenance staff and others working in the local area shall be instructed on the nature of work being carried out. Work in confined spaces shall be avoided. The area around the work space shall be sectioned off. Ensure that the conditions within the area have been made safe by control of flammable material.

4. Checking for presence of refrigerant

The area shall be checked with an appropriate refrigerant detector prior to and during work, to ensure the technician is aware of potentially flammable atmospheres. Ensure that the leak detection equipment being used is suitable for use with flammable refrigerants, i.e. no sparking, adequately sealed or intrinsically safe.

5. Presence of fire extinguisher

If any hot work is to be conducted on the refrigeration equipment or any associated parts, appropriate fire extinguishing equipment shall be available to hand. Have a dry power or CO₂ fire extinguisher adjacent to the charging area.

6. No ignition sources

No person carrying out work in relation to a refrigeration system which involves exposing any pipe work that contains or has contained flammable refrigerant shall use any sources of ignition in such a manner that it may lead to the risk of fire or explosion. All possible ignition sources, including cigarette smoking, should be kept sufficiently far away from the site of installation, repairing, removing and disposal, during which flammable refrigerant can possibly be released to the surrounding space. Prior to work taking place, the area around the equipment is to be surveyed to make sure that there are no flammable hazards or ignition risks. "NO SMOKING" signs shall be displayed.

7. Ventilated area

Ensure that the area is in the open or that it is adequately ventilated before breaking into the system or conducting any hot work. A degree of ventilation shall continue during the period that the work is carried out. The ventilation should safely disperse any released refrigerant and preferably expel it externally into the atmosphere.

8. Checks to the refrigeration equipment

Where electrical components are being changed, they shall be fit for the purpose and to the correct specification. At all times the manufacturer's maintenance and service guidelines shall be followed. If in doubt consult the manufacturer's technical department for assistance. The following checks shall be applied to installations using flammable refrigerants:

- the charge size is in accordance with the room size within which the refrigerant containing parts are installed;
- the ventilation machinery and outlets are operating adequately and are not obstructed;
- if an indirect refrigerating circuit is being used, the secondary circuits shall be checked for the presence of refrigerant; marking to the equipment continues to be visible and legible.
- marking and signs that are illegible shall be corrected;
- refrigeration pipe or components are installed in a position where they are unlikely to be exposed to any substance which may corrode refrigerant containing components, unless
- the components are constructed of materials which are inherently resistant to being
- corroded or are suitably protected against being so corroded.

9. Checks to electrical devices

Repair and maintenance to electrical components shall include initial safety checks and component inspection procedures. If a fault exists that could compromise safety, then no electrical supply shall be connected to the circuit until it is satisfactorily dealt with. If the fault cannot be corrected immediately but it is necessary to continue operation, and adequate temporary solution shall be used. This shall be reported to the owner of the equipment so all parties are advised.

Initial safety checks shall include:

- that capacitors are discharged: this shall be done in a safe manner to avoid possibility of sparking
- that there no live electrical components and wiring are exposed while charging, recovering or purging the system;
- that there is continuity of earth bonding.

10. Repairs to sealed components

10.1 During repairs to sealed components, all electrical supplies shall be disconnected from the equipment being worked upon prior to any removal of sealed covers, etc. If it is absolutely necessary to have an electrical supply to equipment during servicing, then a permanently operating form of leak detection shall be located at the most critical point to warn of a potentially hazardous situation.

10.2 Particular attention shall be paid to the following to ensure that by working on electrical components, the casing is not altered in such a way that the level of protection is affected.

This shall include damage to cables, excessive number of connections, terminals not made to original specification, damage to seals, incorrect fitting of glands, etc.

- Ensure that apparatus is mounted securely.
- Ensure that seals or sealing materials have not degraded such that they no longer serve the purpose of preventing the ingress of flammable atmospheres. Replacement parts shall be in accordance with the manufacturer's specifications.

NOTE: The use of silicon sealant may inhibit the effectiveness of some types of leak detection equipment. Intrinsically safe components do not have to be isolated prior to working on them.

11. Repair to intrinsically safe components

Do not apply any permanent inductive or capacitance loads to the circuit without ensuring that this will not exceed the permissible voltage and current permitted for the equipment in use. Intrinsically safe components are the only types that can be worked on while live in the presence of a flammable atmosphere. The test apparatus shall be at the correct rating. Replace components only with parts specified by the manufacturer. Other parts may result in the ignition of refrigerant in the atmosphere from a leak.

12. Cabling

Check that cabling will not be subject to wear, corrosion, excessive pressure, vibration, sharp edges or any other adverse environmental effects. The check shall also take into account the effects of aging or continual vibration from sources such as compressors or fans.

13. Detection of flammable refrigerants

Under no circumstances shall potential sources of ignition be used in the searching for or detection of refrigerant leaks. A halide torch(or any other detector using a naked flame) shall not be used.

14. Leak detection methods

The following leak detection methods are deemed acceptable for systems containing flammable refrigerants. Electronic leak detectors shall be used to detect flammable refrigerants, but the sensitivity may not be adequate, or may need re-calibration.(Detection equipment shall be calibrated in a refrigerant-free area.) Ensure that the detector is not a potential source of ignition and is suitable for the refrigerant. Leak detection equipment shall be set at a percentage of the LFL of the refrigerant and shall be calibrated to the refrigerant employed and the appropriate percentage of gas (25% maximum) is confirmed. Leak detection fluids are suitable for use with most refrigerants but the use of detergents containing chlorine shall be avoided as the chlorine may react with the refrigerant and corrode the copper pipe-work.

If a leak is suspected ,all naked flames shall be removed or extinguished. If a leakage of refrigerant is found which requires brazing, all of the refrigerant shall be recovered from the system, or isolated(by means of shut off valves) in a part of the system remote from the leak . Oxygen free nitrogen(OFN) shall then be purged through the system both before and during the brazing process.

15. Removal and evacuation

When breaking into the refrigerant circuit to make repairs of for any other purpose conventional procedures shall be used, However, it is important that best practice is followed since flammability is a consideration. The following procedure shall be adhered to:

- remove refrigerant;
- purge the circuit with inert gas;
- evacuate;
- purge again with inert gas;
- open the circuit by cutting or brazing.

The refrigerant charge shall be recovered into the correct recovery cylinders. The system shall be flushed with OFN to render the unit safe. This process may need to be repeated several times. Compressed air or oxygen shall not be used for this task.

Flushing shall be achieved by breaking the vacuum in the system with OFN and continuing to fill until the working pressure is achieved, then venting to atmosphere, and finally pulling down to a vacuum. This process shall be repeated until no refrigerant is within the system.

When the final OFN charge is used, the system shall be vented down to atmospheric pressure to enable work to take place. This operation is absolutely vital if brazing operations on the pipe-work are to take place.

Ensure that the outlet for the vacuum pump is not closed to any ignition sources and there is ventilation available.

16. Charging procedures

In addition to conventional charging procedures, the following requirements shall be followed:

- Ensure that contamination of different refrigerants does not occur when using charging equipment. Hoses or lines shall be as short as possible to minimize the amount of refrigerant contained in them.
- Cylinders shall be kept upright.
- Ensure that the refrigeration system is earthed prior to charging the system with refrigerant.
- Label the system when charging is complete(if not already).
- Extreme care shall be taken not to overfill the refrigeration system.
- Prior to recharging the system it shall be pressure tested with OFN. The system shall be leak tested on completion of charging but prior to commissioning. A follow up leak test shall be carried out prior to leaving the site.

17. Decommissioning

Before carrying out this procedure, it is essential that the technician is completely familiar with the equipment and all its detail. It is recommended good practice that all refrigerants are recovered safely. Prior to the task being carried out, an oil and refrigerant sample shall be taken.

In case analysis is required prior to re-use of reclaimed refrigerant. It is essential that electrical power is available before the task is commenced.

- a) Become familiar with the equipment and its operation.
- b) Isolate system electrically
- c) Before attempting the procedure ensure that:
 - mechanical handling equipment is available, if required, for handling refrigerant cylinders;
 - all personal protective equipment is available and being used correctly;
 - the recovery process is supervised at all times by a competent person;
 - recovery equipment and cylinders conform to the appropriate standards.
- d) Pump down refrigerant system, if possible.
- e) If a vacuum is not possible, make a manifold so that refrigerant can be removed from various parts of the system.
- f) Make sure that cylinder is situated on the scales before recovery takes place.
- g) Start the recovery machine and operate in accordance with manufacturer's instructions.
- h) Do not overfill cylinders. (No more than 80% volume liquid charge).
- i) Do not exceed the maximum working pressure of the cylinder, even temporarily.
- j) When the cylinders have been filled correctly and the process completed, make sure that the cylinders and the equipment are removed from site promptly and all isolation valves on the equipment are closed off.
- k) Recovered refrigerant shall not be charged into another refrigeration system unless it has been cleaned and checked.

18. Labelling

Equipment shall be labelled stating that it has been de-commissioned and emptied of refrigerant. The label shall be dated and signed. Ensure that there are labels on the equipment stating the equipment contains flammable refrigerant.

19. Recovery

- When removing refrigerant from a system, either for service or decommissioning, it is recommended good practice that all refrigerants are removed safely.
- When transferring refrigerant into cylinders, ensure that only appropriate refrigerant recovery cylinders are employed. Ensure that the correct numbers of cylinders for holding the total system charge are available. All cylinders to be used are designated for the recovered refrigerant and labelled for that refrigerant (i.e special cylinders for the recovery of refrigerant). Cylinders shall be complete with pressure relief valve and associated shut-off valves in good working order.
- Empty recovery cylinders are evacuated and, if possible, cooled before recovery occurs.
- The recovery equipment shall be in good working order with a set of instructions concerning the equipment that is at hand and shall be suitable for the recovery of flammable refrigerants. In addition, a set of calibrated weighing scales shall be available
- and in good working order.
- Hoses shall be complete with leak-free disconnect couplings and in good condition. Before using the recovery machine, check that it is in satisfactory working order, has been properly maintained and that any associated electrical components are sealed to prevent ignition in the event of a refrigerant release. Consult manufacturer if in doubt.
- The recovered refrigerant shall be returned to the refrigerant supplier in the correct recovery cylinder, and the relevant Waste Transfer Note arranged. Do not mix refrigerants in recovery units and especially not in cylinders.
- If compressors or compressor oils are to be removed, ensure that they have been evacuated to an acceptable level to make certain that flammable refrigerant does not remain within the lubricant. The evacuation process shall be carried out prior to retruning the compressor to the suppliers. Only electric heating to the compressor body shall be employed to accelerate this process. When oil is drained from a system, it shall be carried out safely.

20. Transportation, marking and storage for units

1. Transport of equipment containing flammable refrigerants
Compliance with the transport regulations
2. Marking of equipment using signs
Compliance with local regulations
3. Disposal of equipment using flammable refrigerants
Compliance with national regulations
4. Storage of equipment/appliances
The storage of equipment should be in accordance with the manufacturer's instructions.
5. Storage of packed (unsold) equipment
Storage package protection should be constructed such that mechanical damage to the equipment inside the package will not cause a leak of the refrigerant charge.
The maximum number of pieces of equipment permitted to be stored together will be determined by local regulations.

The design and specifications are subject to change without prior notice for product improvement. Consult with the sales agency or manufacturer for details. Any updates to the manual will be uploaded to the service website, please check for the latest version.

CF001UI-GDDA
16122200002669
20180528

KAISAI

AIR CONDITIONER REMOTE CONTROL- LER

Installation and Owner's Manual

Thank you for choosing our product.
For proper operation, please read and keep this manual carefully.

If you have lost the Owner's Manual, please contact the local agent or visit www.kaisai.com
or sent email to: handlowy@fgpoland.pl, for electronic version.

CONTENTS

Remote controller Specifications.....	50
Function buttons	51
Handling the remote controller	52
Remote LCD screen indicators	53
How to use the basic functions.....	54
How to use the advanced functions	62

Remote Controller Specifications

Model	RG66A1(B2)/BGEF
Rated Voltage	3.0V(Dry batteries R03/LR03×2)
Signal Receiving Range	8m
Environment	-5°C~60°C(23°F~140°F)

NOTE:

- Buttons design is based on typical model and might be slightly different from the actual one you purchased, the actual shape shall prevail.
- All the functions described are accomplished by the unit. If the unit has no this feature, there is no corresponding operation happened when press the relative button on the remote controller.
- When there are wide differences between "Remote controller Illustration" and "USER'S MANUAL" on function description, the description of "USER'S MANUAL" shall prevail.

Function Buttons

Before you begin using your new air conditioner, make sure to familiarize yourself with its remote control. The following is a brief introduction to the remote control itself. For instructions on how to operate your air conditioner, refer to the **How to Use The Basic/Advance Functions** section of this manual.

NOTE: Please do not select HEAT mode if the machine you purchased is cooling only type. Heat mode is not supported by the cooling only appliance.

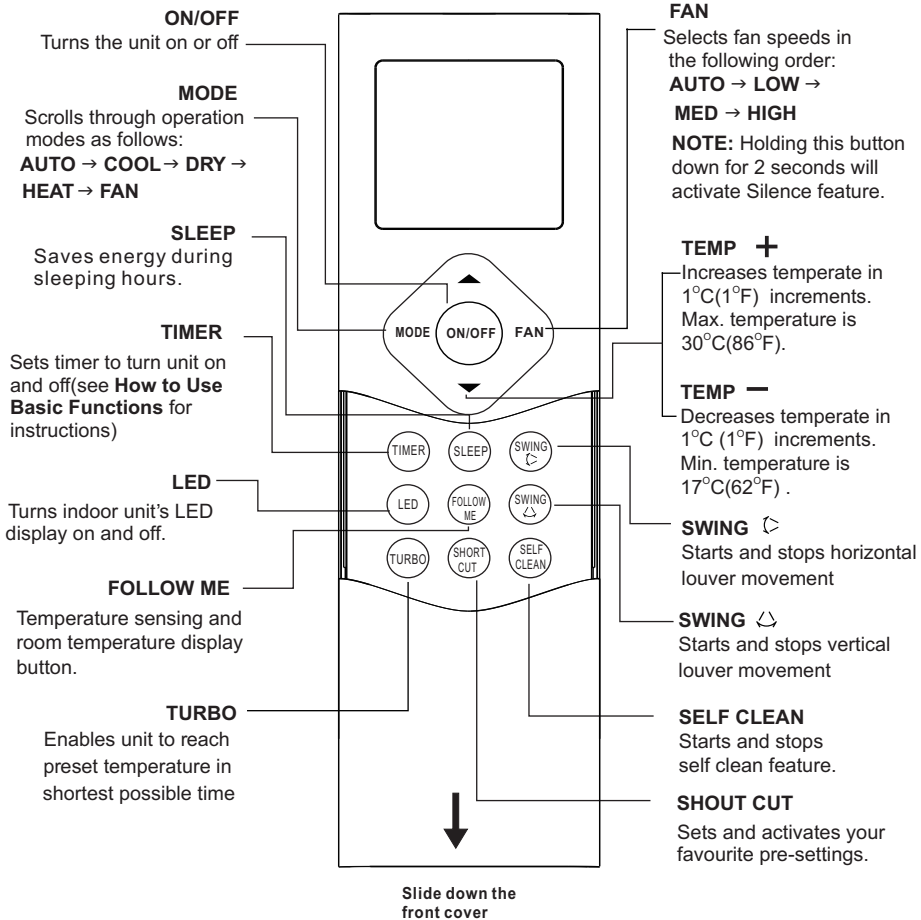

Handling The Remote Controller

NOT SURE WHAT A FUNCTION DOES?

Refer to the **How to Use Basic Functions** and **How to Use Advanced Functions** sections of this manual for a detailed description of how to use your air conditioner.

SPECIAL NOTE

- Button designs on your unit may differ slightly from the example shown.
- If the indoor unit does not have a particular function, pressing that function's button on the remote control will have no effect.

INSERTING AND REPLACING BATTERIES

Your air conditioning unit comes with two AAA batteries. Put the batteries in the remote control before use:

1. Remove the back cover from the remote control, exposing the battery compartment.
2. Insert the batteries, paying attention to match up the (+) and (-) ends of the batteries with the symbols inside the battery compartment.
3. Install the back cover on.

INSTALLING REMOTE CONTROL HOLDER

The remote controller can be attached to a wall or stand by using a remote controller holder (optional part, not supplied with the unit).

1. Before installing the remote controller, check that the air conditioner receives the signals properly.
2. Install the holder with two screws.
3. Put the remote controller in the holder.

! BATTERY NOTES

For optimum product performance:

- Do not mix old and new batteries, or batteries of different types.
- Do not leave batteries in the remote control if you don't plan on using the device for more than 2 months.



BATTERY DISPOSAL

Do not dispose of batteries as unsorted municipal waste. Refer to local laws for proper disposal of batteries.

TIPS FOR USING REMOTE CONTROL

- The remote control must be used within 8 meters of the unit.
- The unit will beep when remote signal is received.
- Curtains, other materials and direct sunlight can interfere with the infrared signal receiver.
- Remove batteries if the remote control will not be used more than 2 months.
- Prevent any liquid from falling into the remote controller. Do not expose the remote controller to direct sunlight or heat.

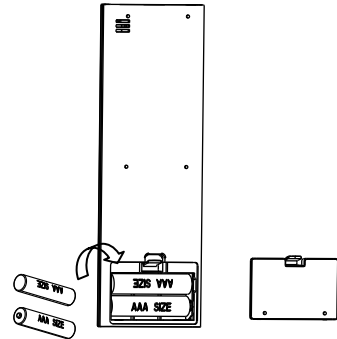

Remove the back cover to install batteries

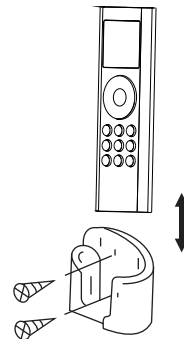

Put the remote controller in the holder.

Remote LCD Screen Indicators

Information are displayed when the remote controller is powered up.

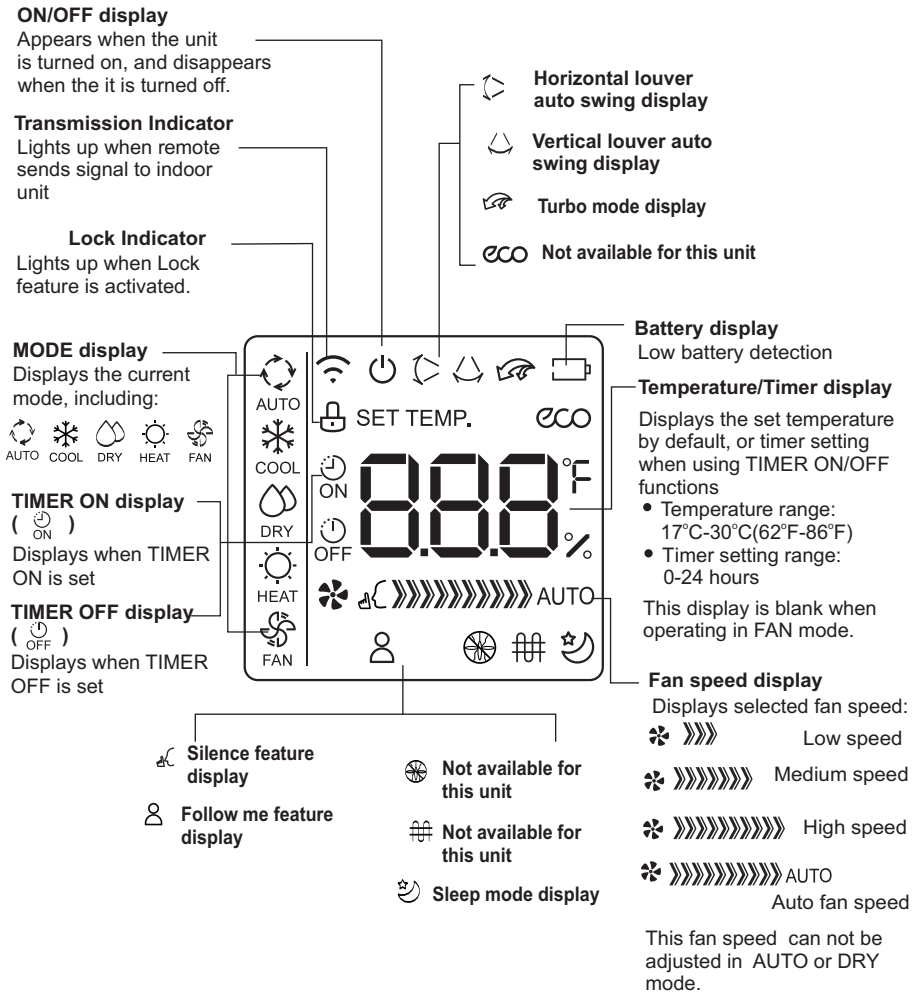

Note:

All indicators shown in the figure are for the purpose of clear presentation. But during the actual operation only the relative functional signs are shown on the display window.

How To Use The Basic Functions

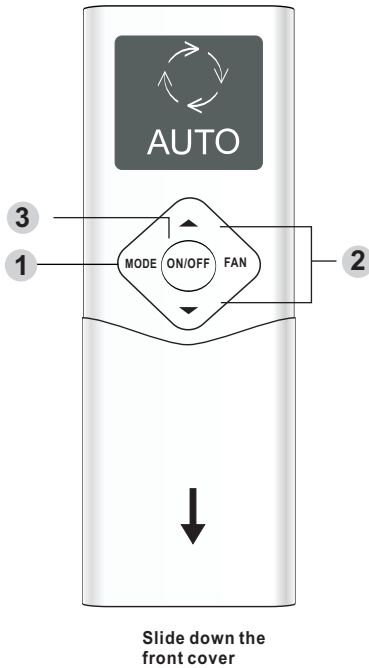

COOL operation

1. Press the **MODE** button to select **COOL** mode.
2. Set your desired temperature using the **Temp ▲** or **Temp ▼** button.
3. Press the **FAN** button to select the fan speed.
4. Press the **ON/OFF** button to start the unit.

SETTING TEMPERATURE

The operating temperature range for units is 17°C-30°C (62°F-86°F). You can increase or decrease the set temperature in 1°C (1°F) increments.

AUTO operation

In **AUTO** mode, the unit will automatically select the **COOL**, **FAN**, **HEAT** or **DRY** mode based on the set temperature.

1. Press the **MODE** button to select Auto mode.
2. Set your desired temperature using the **Temp ▲** or **Temp ▼** button.
3. Press the **ON/OFF** button to start the unit.

NOTE: **FAN SPEED** can't be set in Auto mode.

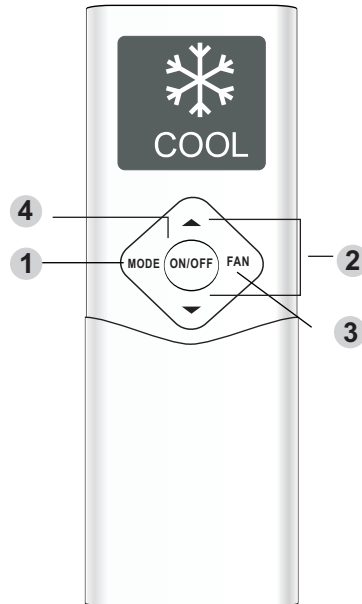

How To Use The Basic Functions

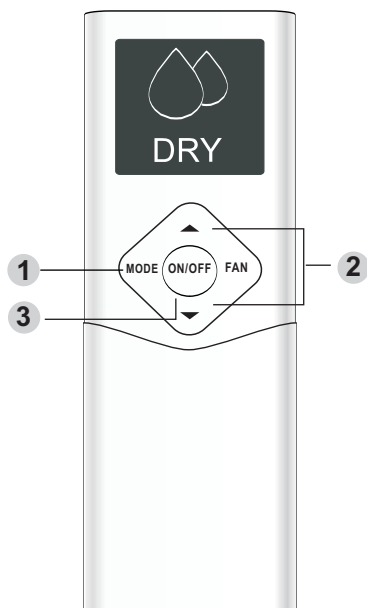

DRY operation(dehumidifying)

1. Press the **MODE** button to select **DRY** mode.
2. Set your desired temperature using the **Temp ▲** or **Temp ▼** button.
3. Press the **ON/OFF** button to start the unit.

NOTE: **FAN SPEED** can't be changed in **DRY** mode.

FAN operation

1. Press the **MODE** button to select **FAN** mode.
2. Press the **FAN** button to select the fan speed.
3. Press the **ON/OFF** button to start the unit.

NOTE: You can't set temperature in **FAN** mode. As a result, your remote control's LCD screen will not display temperature.

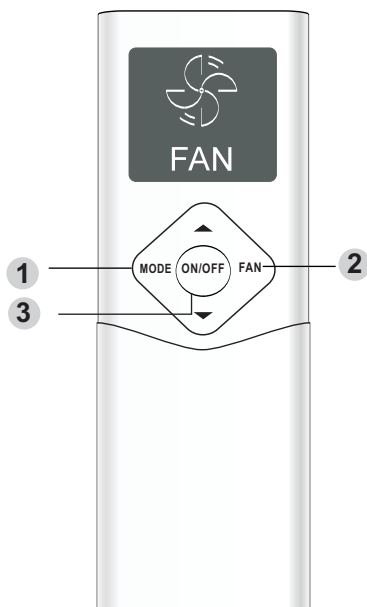

How To Use The Basic Functions

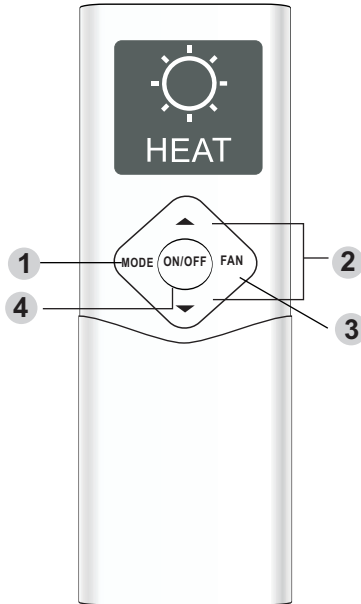

HEAT operation

1. Press the **MODE** button to select **HEAT** mode.
2. Set your desired temperature using the **Temp ▲** or **Temp ▼** button.
3. Press the **FAN** button to select the fan speed.
4. Press the **ON/OFF** button to start the unit.

NOTE: As outdoor temperature drops, the performance of your unit's HEAT function may be affected. In such instances, we recommend using this air conditioner in conjunction with other heating appliance.

Setting the TIMER function

Your air conditioning unit has two timer-related functions:

- **TIMER ON**- sets the amount of timer after which the unit will automatically turn on.
- **TIMER OFF**- sets the amount of time after which the unit will automatically turn off.

TIMER ON function

The **TIMER ON** function allows you to set a period of time after which the unit will automatically turn on, such as when you come home from work.

1. Press the **Timer** button, the Timer on indicator "ON" displays and flashes. By default, the last time period that you set and an "h" (indicating hours) will appear on the display.

Note: This number indicates the amount of time after the current time that you want the unit to turn on.

For example, if you set **TIMER ON** for 2.5 hours, " 2.5h " will appear on the screen, and the unit will turn on after 2.5 hours.

2. Press the Temp ▲ or Temp ▼ button repeatedly to set the time when you want the unit to turn on.
3. Wait 3 seconds, then the **TIMER ON** function will be activated. The digital display on your remote control will then return to the temperature display. The " ON " indicator remains on and this function is activated.

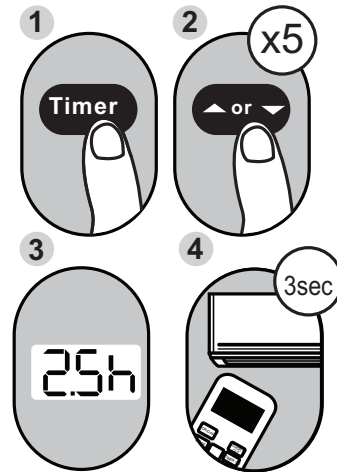



Example: Setting unit to turn on after 2.5 hours.

TIMER OFF function

The **TIMER OFF** function allows you to set a period of time after which the unit will automatically turn off, such as when you wake up.

1. Press the **Timer** button, the Timer off indicator "  " displays and flashes. By default, the last time period that you set and an "h" (indicating hours) will appear on the display.

Note: This number indicates the amount of time after the current time that you want the unit to turn off. For example, if you set **TIMER OFF** for 5 hours, " 5.0h " will appear on the screen, and the unit will turn off after 5 hours.

2. Press the Temp  or Temp  button repeatedly to set the time when you want the unit to turn off.
3. Wait 3 seconds, then the **TIMER OFF** function will be activated. The digital display on your remote control will then return to the temperature display. The "  " indicator remains on and this function is activated.

NOTE: When setting the **TIMER ON** or **TIMER OFF** functions, up to 10 hours, the time will increase in 30 minute increments with each press. After 10 hours and up to 24, it will increase in 1 hour increments. The timer will revert to zero after 24 hours.

You can turn off either function by setting its timer to " 0.0h " .

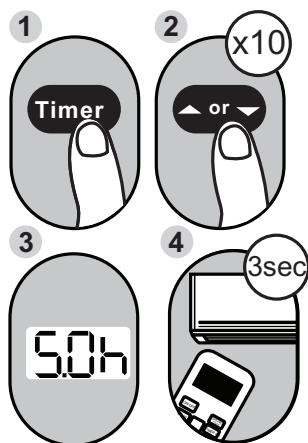

Example: Setting unit to turn off after 5 hours.

Setting both TIMER ON and TIMER OFF at the same time

Keep in mind that the time periods you set for both functions refer to hours after the current time. For example, say that the current time is 1:00 PM, and you want the unit to turn on automatically at 7:00 PM. You want it to operate for 2 hours, then automatically turn off at 9:00 PM.

Do the following:

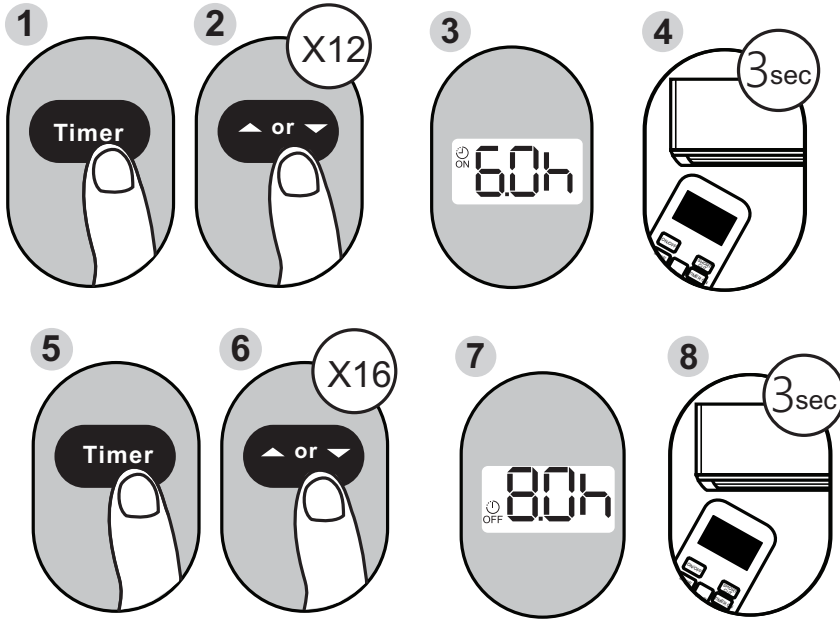

Example: Setting the unit to turn on after 6 hours, operate for 2 hours, then turn off (see the figure below)

Your remote display

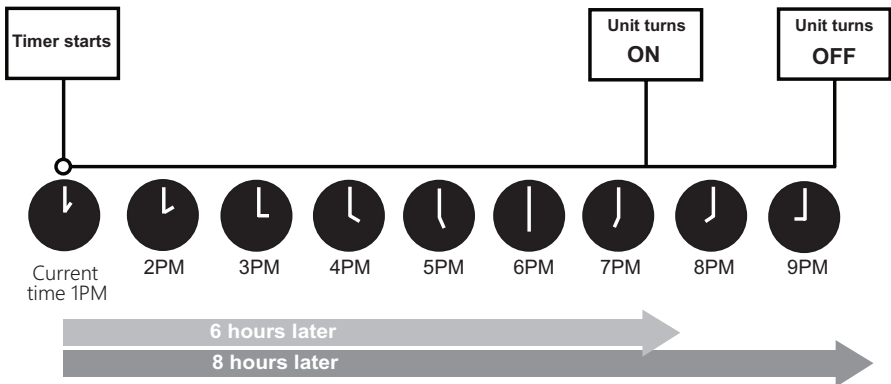
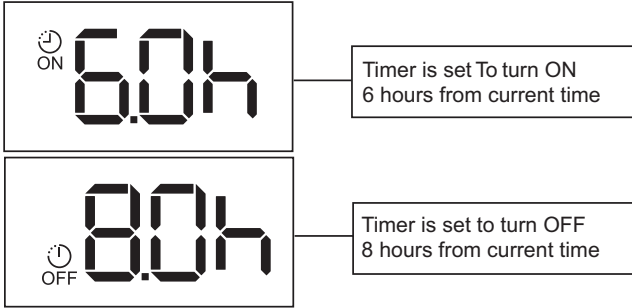

How To Use The Advanced Functions

SLEEP Function

The SLEEP function is used to decrease energy use while you sleep (and don't need the same temperature settings to stay comfortable). This function can only be activated via remote control. For the detail, see "sleep operation" in "USER'S MANUAL"

Note: The SLEEP function is not available in FAN or DRY mode.

Follow me function

The Follow me function enables the remote control to measure the temperature at its current location and send this signal to the air conditioner every 3 minutes interval. When using AUTO, COOL, or HEAT modes, measuring ambient temperature from the remote control (instead of from the indoor unit itself) will enable the air conditioner to optimize the temperature around you and ensure maximum comfort.

Silence function

Hold down Fan speed button for 2 seconds to activate/cancel **Silent** mode. Due to low frequency operation of compressor, it may result in insufficient cooling and heating capacity.
(applicable to the air conditioner with Silent feature only)

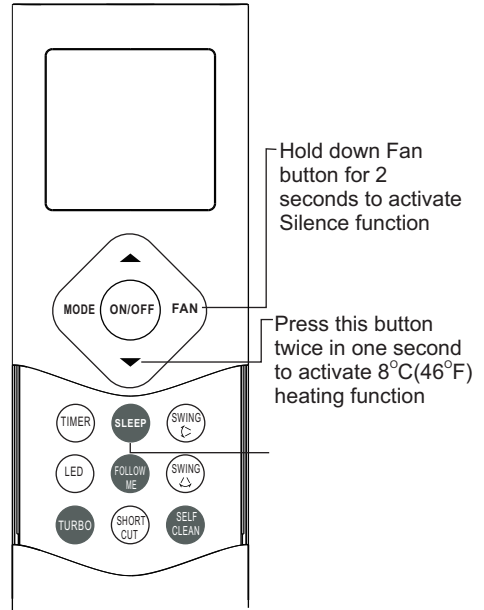

NOTE: Press and hold Temp + and - buttons together for 3 seconds will alternate the temperature display between the °C & °F scale.

8°C Heating Function

When the air conditioner operates under heating mode with the set temperature of 17°C(62°F), press Temp - button twice in one second will activate 8 Degree heating function. The unit will operate at a setting temperature of 8°C(46°F). The indoor unit display shows "FP".
(applicable to the air conditioner with 8°C Heating feature only)

How To Use The Advanced Functions

SWING function



Button

Used to stop or start vertical louver movement and set the desired left/right air flow direction. The vertical louver changes 6 degree in angle for each press. If keep pushing more than 2 seconds, the vertical louver auto swing feature is activated.



Button

Used to stop or start horizontal louver movement or set the desired up/down air flow direction. The louver changes 6 degree in angle for each press. If keep pushing more than 2 seconds, the louver will swing up and down automatically.

SELF CLEAN function

Airborne bacteria can grow in the moisture that condenses around heat exchanger in the unit. With regular use, most of this moisture is evaporated from the unit. When the **SELF CLEAN** feature is activated, your unit will clean itself automatically. After that, the unit will turn off automatically. You can use **SELF CLEAN** as often as you like. (Applicable to the air conditioner with SELF CLEAN feature only)

Note: You can only activate this function in COOL or DRY mode.

TURBO function

The TURBO function makes the unit work extra hard to reach your present temperature in the shortest amount of time possible.

- When you select **TURBO** feature in COOL mode, the unit will blow cool air with strongest wind setting to jump-start the cooling process.
- When you select **TURBO** feature in HEAT mode, for units with Electric heat elements, the Electric Heater will activate and jump-start the heating process.

LOCK function

Press Turbo button and Self clean button simultaneously for one second to lock or unlock the keyboard.

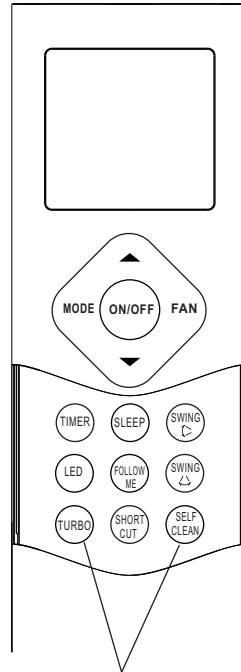

Hold together for one second to activate LOCK function

SHORTCUT function

- Used to restore the current settings or resume previous settings.
- Push this button when remote controller is on, the system will automatically revert back to the previous settings including operating mode, setting temperature, fan speed level and sleep feature (if activated).
- If pushing more than 2 seconds, the system will automatically restore the current operation settings including operating mode, setting temperature, fan speed level and sleep feature (if activated).

...the first of these is the fact that the ...

...the second of these is the fact that the ...

...the third of these is the fact that the ...

...the fourth of these is the fact that the ...

...the fifth of these is the fact that the ...

...the sixth of these is the fact that the ...

...the seventh of these is the fact that the ...

...the eighth of these is the fact that the ...

...the ninth of these is the fact that the ...

...the tenth of these is the fact that the ...

...the eleventh of these is the fact that the ...

...the twelfth of these is the fact that the ...

...the thirteenth of these is the fact that the ...

...the fourteenth of these is the fact that the ...

...the fifteenth of these is the fact that the ...

...the sixteenth of these is the fact that the ...

...the seventeenth of these is the fact that the ...

...the eighteenth of these is the fact that the ...

...the nineteenth of these is the fact that the ...

...the twentieth of these is the fact that the ...

**WE
CARE
ABOUT
AIR**

kaisai.com