

UTY-RHKY
UTY-RHKG
UTY-RHKYT

INSTALLATION MANUAL

SIMPLE REMOTE CONTROLLER
For authorized service personnel only.

English

INSTALLATIONSANLEITUNG

EINFACHE FERNBEDIENUNG
Nur für autorisiertes Fachpersonal.

Deutsch

MANUEL D'INSTALLATION

TÉLÉCOMMANDE SIMPLE
Pour le personnel d'entretien autorisé uniquement.

Français

MANUAL DE INSTALACIÓN

MANDO A DISTANCIA SIMPLE
Únicamente para personal de servicio autorizado.

Español

MANUALE DI INSTALLAZIONE

TELECOMANDO SEMPLICE
A uso esclusivo del personale tecnico autorizzato.

Italiano

ΕΓΧΕΙΡΙΔΙΟ ΕΓΚΑΤΑΣΤΑΣΗΣ

ΑΠΛΟ ΤΗΛΕΧΕΙΡΙΣΤΗΡΙΟ
Μόνο για εξουσιοδοτημένο τεχνικό προσωπικό.

Ελληνικά

MANUAL DE INSTALAÇÃO

CONTROLO REMOTO SIMPLES
Apenas para pessoal de assistência autorizado.

Português

РУКОВОДСТВО ПО УСТАНОВКЕ

ПРОСТОЙ ПРОВОДНОЙ ПУЛЬТ ДУ
Только для авторизованного обслуживающего персонала.

Русский

KURULUM KILAVUZU

BASİT UZAKTAN KUMANDA
Yalnızca yetkili servis personeli için.

Türkçe

安装说明书

简易遥控器
仅针对授权的专业维修人员。

中文

INSTALLATION MANUAL

PART NO. 9371068084-09
SIMPLE REMOTE CONTROLLER

CONTENTS

| | |
|--|---|
| 1. SAFETY PRECAUTIONS | 1 |
| 2. MAIN UNIT AND ACCESSORIES | 1 |
| 3. ELECTRICAL REQUIREMENT | 1 |
| 4. SELECTING AN INSTALLATION LOCATION..... | 1 |
| 4.1. Dimensions | 1 |
| 4.2. Name of parts..... | 2 |
| 5. INSTALLING THE REMOTE CONTROLLER..... | 2 |
| 5.1. Installation | 2 |
| 5.2. Setting the DIP switch | 3 |
| 5.3. Connection of Remote Controller Cable | 3 |
| 6. INSTALLATION METHODS | 4 |
| 6.1. Group control | 4 |
| 6.2. Dual remote control..... | 5 |
| 7. TURNING ON THE POWER..... | 5 |
| 8. ADDRESS SETTING | 5 |
| 9. FUNCTION SETTING | 6 |
| 10. TEST RUN..... | 7 |
| 11. FILTER LAMP RESET | 7 |
| 12. ERROR CODE | 7 |

1. SAFETY PRECAUTIONS

- The "SAFETY PRECAUTION" indicated in this manual contain important information pertaining to your safety. Be sure to observe them.
- Request the user to keep this manual on hand for future use, such as for relocating or repairing the unit.

| | |
|---|---|
|  WARNING | This mark indicates procedures which, if improperly performed, might lead to the death or serious injury of the user. |
| Perform installation work in accordance with this manual and the electrical wiring regulations or implementation regulations of the country. Do not install this unit by yourself. Improper installation work will cause injury, electric shock, fire, etc. | |
| In the event of a malfunction (burning smell, etc.), immediately stop operation, turn off the electrical breaker, and consult authorized service personnel. If it is neglected, it will cause electric shock or a fire. | |
| Do not install this unit in the following areas: | |
| <ul style="list-style-type: none"> • Do not install the unit near a source of heat, steam, or flammable gas. Otherwise, fire could result. • Area containing equipment that generates electromagnetic interference. It will cause malfunction of the control system. • Install the unit in a well-ventilated place avoiding rains and direct sunlight. | |
| Do not operate this unit when your hands are wet. Touching the unit with wet hands will cause an electric shock. | |
| If there is a possibility of children approaching the unit during construction, take preventive measures. Otherwise, injury or electrical shock could result. | |
| Dispose of the packing materials safely. Tear and dispose of the plastic packing bags so that children cannot play with them. There is the danger of suffocation if children play with the original plastic bags. | |

CAUTION







This mark indicates procedures which, if improperly performed, might possibly result in personal harm to the user or damage to property.

Do not touch the switches with sharp objects. It will cause injury, trouble, or electrical shock.

Do not expose this unit directly to water. It will cause trouble, electrical shock, or heating.

2. MAIN UNIT AND ACCESSORIES

The following installation parts are supplied. Use them as required.

| Name and Shape | Q'ty | Name and Shape | Q'ty |
|---|------|--|------|
| Simple remote controller  | 1 | Remote controller cable (*) (10m)  | 1 |
| Installation manual  | 1 | Screw (M4 x 16mm)  | 2 |
| Operating manual  | 1 | Cable tie  | 1 |

(*) UTY-RHKYT does not contain cables.

3. ELECTRICAL REQUIREMENT

When connecting the remote controller use the following wiring.

| Use | Size | Length | Wire type | Remarks |
|-------------------------|------------------------------|------------|--------------|--|
| Remote controller cable | 0.33 mm ² (22AWG) | 500 m max. | Polar 3 core | Use shield cable in accordance with local rules for cable. |

4. SELECTING AN INSTALLATION LOCATION

4.1. Dimensions

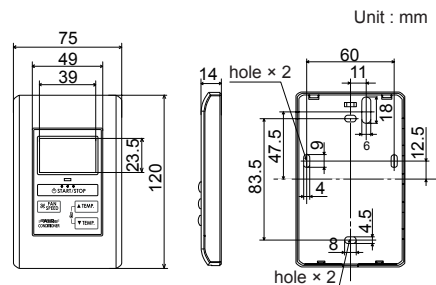

4.2. Name of parts

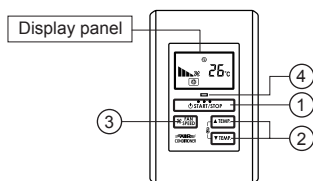

• Display panel

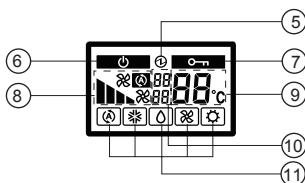

- ① " ⏻ START/STOP " (START/STOP Button)
- ② " 🔥 ▲ TEMP. ", " ❄️ ▼ TEMP. " (Set Temperature Button)
- ③ " 🌀 FAN SPEED " (Fan Control Button)
- ④ Operation Lamp Indicator
- ⑤ Electric energy Indicator
- ⑥ Standby Indicator
- ⑦ Operation Lock Indicator
- ⑧ Fan Speed Indicator
- ⑨ Temperature Indicator
- ⑩ Error Indicator
- ⑪ Operation Mode Indicator

5. INSTALLING THE REMOTE CONTROLLER

⚠️ WARNING

Always use the accessories and specified installation work parts. Not using the specified parts will cause units to fall off, electric shock, fire, etc.

Install at a place that can withstand the weight of the unit and install positively so that the unit will not topple or fall.

During installation work, do not permit children or users to approach. It will cause injury or electric shock.

Before starting installation work, turn off the power of indoor unit power supply. Do not turn on the power again until installation is completed. Otherwise, it will cause electric shock or fire.

Use the attached cable. If extending or branching, implement suitable measures. When connecting the cables to the terminal, make sure to connect securely. Improper installation work may cause electric shock, fire, or heat.

Install the remote controller cables securely to the terminal block. Confirm that external force is not applied to the cable. If insertion fixing are imperfect, it will cause electric shock, or fire, etc.

Perform functional earthing work positively. Do not connect the functional earthing wire to a telephone functional earthing wire, water pipe, or conductor rod.

Always fasten the outside covering of the connection cable with the cable tie. If the insulator is loose, short circuit may occur.

When performing cable wiring work, be sure that it does not touch the user. It will cause injury or electric shock.

⚠️ CAUTION

Do not set the DIP switch of this unit except as specified in this manual or the operating manual supplied with the air conditioner. Setting the switches other than specified will cause an accident or trouble.

Use an insulated screwdriver to set the DIP switches.

Before opening the case of this unit, completely discharge static electricity charged on you body. Not doing so will cause trouble.

Do not touch the PC board and PC board parts directly with your hands. Otherwise, injury or electric shock could result.

Tightening the mounting screws too tight will damage the case of this unit.

Be careful so that the front case does not fall after the front case screws are removed. Otherwise, injury could result.

Install the remote controller cables 1 m away from television and radio to avoid distorted images and noise.

Make sure water and insects do not enter the unit. Use putty, etc., as a countermeasure to gaps that may provide a route of ingress. Water and insects may cause malfunction, electric shock, or fire.

Confirm the name of each terminal block of the unit and connect the wiring in accordance with the directions given in the manual so that there is no incorrect wiring. Improper wiring work will damage the electric parts and cause smoke and fire.

When installing the remote controller cable near a source of electromagnetic waves, use shielded cable. Otherwise, a breakdown or malfunction could result.

5.1. Installation

Insert the end of a flat blade screwdriver at the ↑ of the groove at the side of the rear case and remove the rear case top by turning the screwdriver.

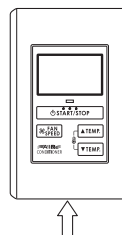

⚠️ CAUTION

Be careful to avoid breaking the cable by over-tightening the cable tie.

When connecting the remote controller cables, do not overtighten the screws.

- (1) Pass the remote controller cable through the hole in the rear case and connect the remote controller cable to the remote controller terminal block specified in Fig. 1.
- (2) Clamp the remote controller cable sheath with the cable tie as shown in Fig. 1.

Fig. 1

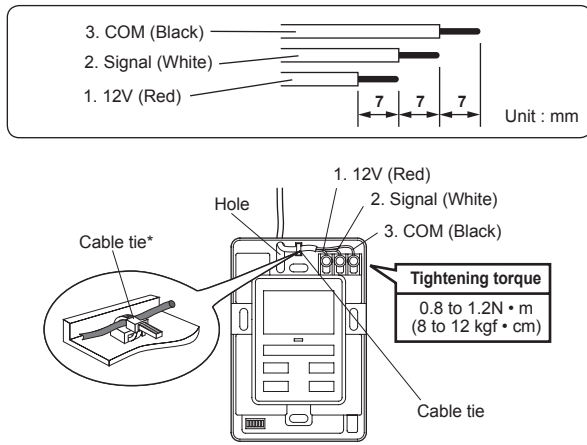

*Tighten the cable tie firmly so that pulling force does not propagate to the terminal connection even if force of 30N is applied to the cable.

- (3) Cut off the excess cable tie.
- (4) Install the rear case to the wall, box, etc., with 2 screws (Fig. 2).

Fig. 2

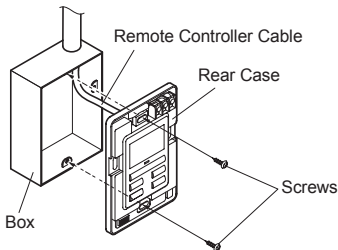

CAUTION

Insert the upper case firmly. If improperly attached, it will cause the upper case to fall off.

When installing remote control cables, cover the remote control cables using an isolation tube or cover at least 1mm thick minimum to prevent direct contact with the cables.

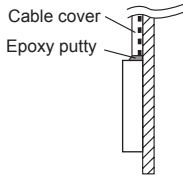

Perform functional earthing the remote controller if it has a functional earthing cable. (UTY-RHKYT)

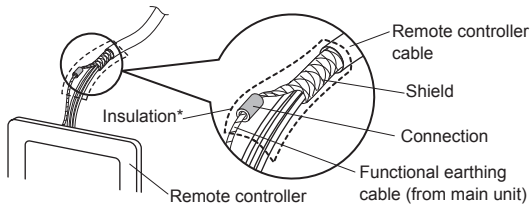

* Wrap the connector and remote controller cables with vinyl tape or some other type of insulation as shown in the figure.

5.2. Setting the DIP switch

Set the remote controller DIP switches. (Fig. 1)

Fig. 1

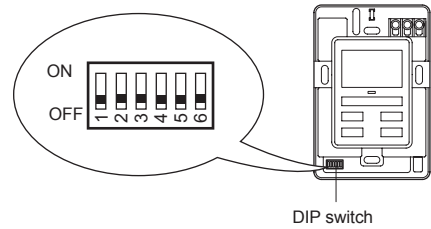

| | NO. | Switch state | | Detail |
|------------|----------|----------------|-------|-----------------------------------|
| | | OFF | ON | |
| DIP switch | 2 | ★ Master | Slave | Refer to 6. INSTALLATION METHODS. |
| | 1,3 to 6 | ★ Fixed at OFF | | Cannot be used |

(★ Factory setting)

5.3. Connection of Remote Controller Cable

CAUTION

When connecting the remote controller cable to the indoor unit, do not connect it to outdoor unit, power supply cable, or transmission cable terminal blocks. It may cause a failure.

When switching the DIP switch (SW1), be sure to turn off the power supply to the indoor unit. Otherwise, the PC board of the indoor unit may be damaged.

- There are 2 methods to connect the remote controller cable to the indoor unit. One is the connection using connecting cable (shipped with the indoor unit), and the other is the connection the remote controller cable is connected to the exclusive terminal block of the indoor unit.
- This is 3WIRE of remote control cables.
- The factory default setting of the DIP switch (SW1) is "2WIRE". (Indoor unit) Using this setting, however, will disable normal operations.

5.3.1. Check whether or not a DIP switch (SW1) is present.

Find the DIP switch (SW1), which switches between 2WIRE and 3WIRE on the indoor unit PC board.

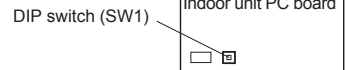

- If there is no DIP switch (SW1), proceed to the next step.

- If the DIP switch (SW1) is present.

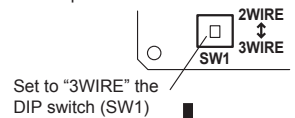

5.3.2. Check whether the indoor unit terminal block or connectors are either type A or type B as described below.

Make sure to implement the connection method suitable for each type according to the explanation below.

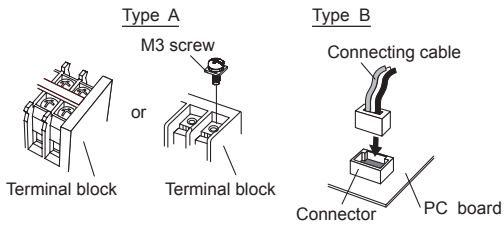

• Type A (Terminal block)

- (1) Cut the Y-type remote control cable terminal, and remove the insulation from the cut end of the cable. (Fig. 1)

Fig. 1

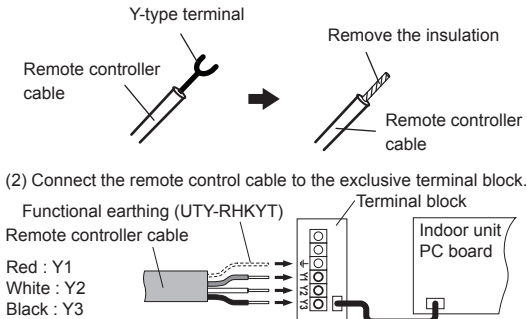

Tightening torque

| | |
|--|-----------------------------------|
| M3 screw (Remote controller / Y1, Y2, Y3) | 0.5 to 0.6 N·m (5 to 6 kgf·cm) |
|--|-----------------------------------|

• Type B (Connector)

- (1) Use a tool to cut off the Y-type terminal on the end of the remote controller cable, and then remove the insulation from the cut end of the cable as shown in Fig. 2. Connect the remote controller cable and connecting cable as shown in Fig. 3. Be sure to insulate the connection between the cables.

Fig. 2

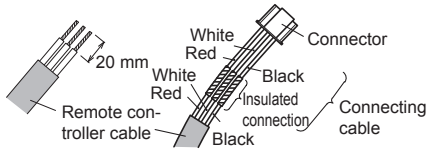
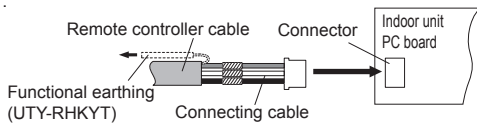

Fig. 3

- (2) Connect the remote controller cable to the connecting cable, and insert it to the connector.

Example 1.



Example 2.

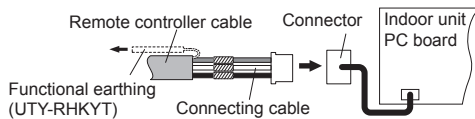

Note: The DIP switch, exclusive terminal block, and connector layouts depends on the type of indoor unit. For details, see the indoor unit installation manuals.

Be careful of the following when connecting 2 cables to 1 terminal.

GOOD

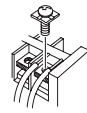

PROHIBITED

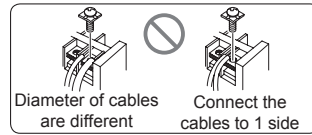

6. INSTALLATION METHODS

6.1. Group control

- (1) Wiring method (indoor unit to remote controller)

• Type A (Terminal block)

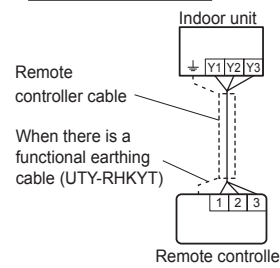

• Type B (Connector)

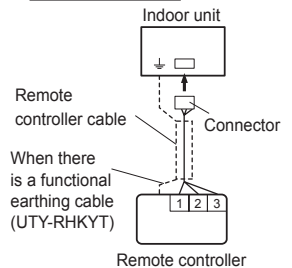

A number of indoor units can be operated at the same time using a single remote controller.

• Type A (Terminal block)

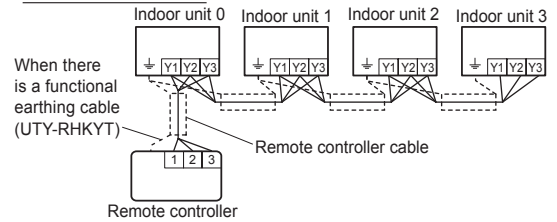

• Type B (Connector)

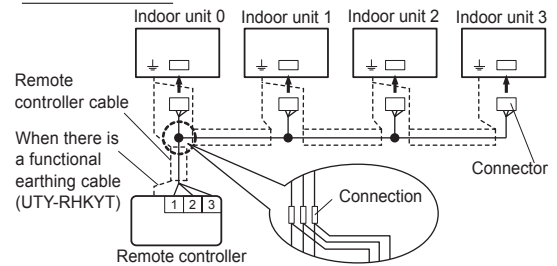

- (2) Remote controller address setting of indoor unit
Set each remote controller address using the switch of each indoor unit in order from 0. (Refer to the installation manual for the indoor unit.)
Up to 16 indoor units can be connected.

6.2. Dual remote control

- 2 remote controllers can be used to operate the indoor units.
- The timer cannot be used on the slave units.
- ADDRESS SETTING and FUNCTION SETTING cannot be used on the slave units.
- The remote controller (UTB- * LA) and remote controller (UTB- * U * , UTB- * P * , UTB- * R *) cannot be connected at the same time.

(1) Wiring method

(Indoor unit to remote controller)

• Type A (Terminal block)

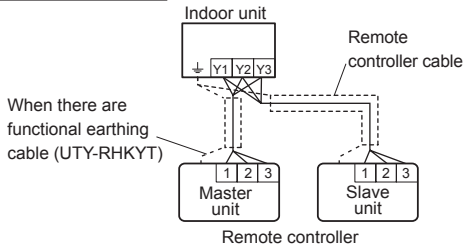

• Type B (Connector)

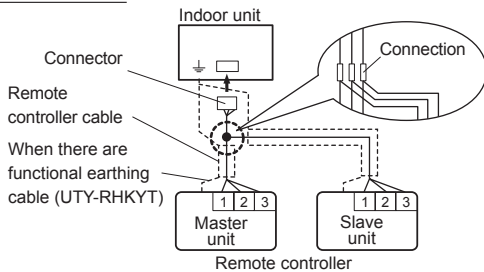

(2) Remote controller DIP Switch 1- No. 2 setting

Set the remote controller DIP switch 1- No. 2 according to the following table.

| Number of remote controllers | Master unit | Slave unit |
|------------------------------|----------------------|----------------------|
| | DIP switch 1 - No. 2 | DIP switch 1 - No. 2 |
| 1 (Single) | OFF | - |
| 2 (Dual) | OFF | ON |

- Group control and dual remote control can be used together.
- When connecting 2 remote controllers, the remote controller can also be connected together with another type of remote controller.

7. TURNING ON THE POWER

CAUTION

Recheck the wiring. Incorrect wiring will cause trouble.

- Check the remote controller wiring and DIP switch settings.
- Install the front case.
 - * When installing the front case, connect the connector to the front case (in 5 INSTALLING THE REMOTE CONTROLLER).
- Check the indoor and outdoor unit wiring and PC board switch settings, and then turn on the indoor and outdoor units.
 - After "SE" has flashed on the set temperature indicator for several second, the ① mark will be displayed in the center of the remote controller display.
 - * For the wiring and PC board switch settings method, refer to the installation manual for the indoor unit and outdoor unit.

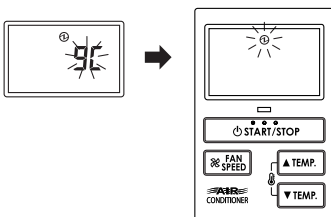

8. ADDRESS SETTING

Address setting method of indoor unit can be selected from 3 options (outdoor unit, indoor unit and remote controller).

Refer to the installation manual of outdoor unit or indoor unit when set up from the outdoor unit or the indoor unit.

- "Indoor unit address" and "Refrigerant circuit address" can be set using the remote controller.
- This function can be set in all indoor units when the remote controller is connected.
- "Remote controller address" cannot be set in this function. Ensure to set with the Rotary switch of PC board of the indoor unit.
- When setting the address of indoor unit, refer to installation manual of indoor unit.
- When setting the address of outdoor unit automatically, refer to installation manual of outdoor unit.
- When setting the address with a remote controller, refer to installation manual of indoor unit for setting details of indoor unit.

Switching selection of address setting mode

- Press the "▲ TEMP." button, "▼ TEMP." button and "FAN SPEED" button for more than 5 seconds simultaneously. Then shift to Address setting mode.



- Press the "▲ TEMP." button or "▼ TEMP." button and select the Remote controller address (Select the relevant indoor unit). Then press "FAN SPEED" button.

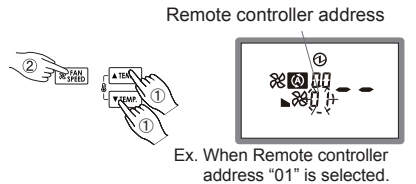

Indoor unit address setting

- "Address code" indicator blinks. Then display Address code "01" by pressing the "▲ TEMP." button or "▼ TEMP." button.

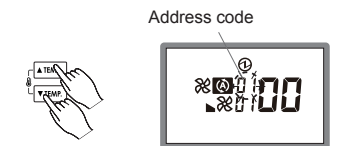

- When the "Address data" blinks by pressing the "FAN SPEED" button set the Indoor unit address data by pressing the "▲ TEMP." button or "▼ TEMP." button. (Range of setting is 00-63.)

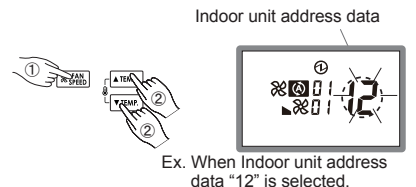

- (5) Fix the Indoor unit address data by pressing the "START/STOP" button. (Data is transferred to the indoor unit).

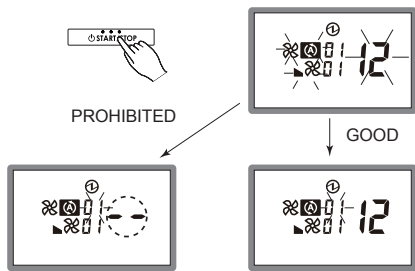

- When Indoor unit address data is not set in the indoor unit. (-- is displayed).
- Set the Indoor unit address data again as per procedures (3)-(5) above.

Refrigerant circuit address setting

- (6) When the "Address code" blinks set the Address code "02" by pressing the "▲ TEMP." button or "▼ TEMP." button.

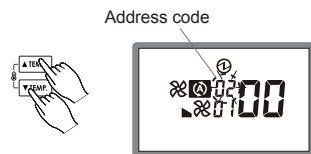

- (7) "Address data" indicator blinks. Then set the Refrigerant circuit address data by pressing the "▲ TEMP." button or "▼ TEMP." button. (Range of setting is 00-99.)

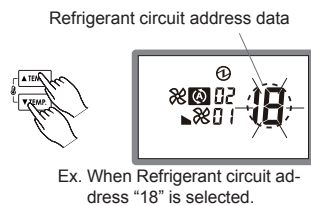

- (8) Fix the Refrigerant circuit address data by pressing the "START/STOP" button. (Data is transferred to the indoor unit).

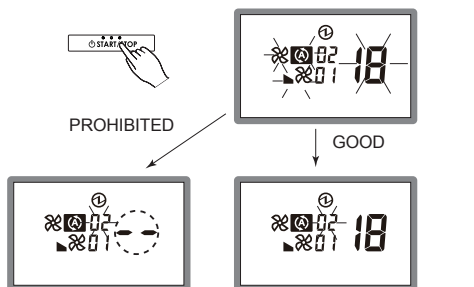

- When Refrigerant circuit address data is not set in the indoor unit. (-- is displayed).
- Set the Refrigerant circuit address data again as per procedure (6)-(8) above.

Completion of address setting mode

- (9) Address setting mode is released and returns to normal display if the "▲ TEMP." button, "▼ TEMP." button and "FAN SPEED" button are pressed for more than 5 seconds simultaneously.

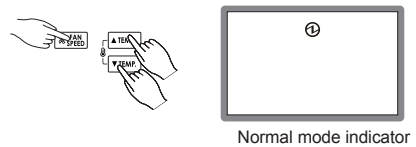

- * Address setting mode is released automatically if no key is pressed for 60 seconds even the above buttons are not pressed. (Switch to Address setting mode as per procedure (1) above.)

- (10) After completing the ADDRESS SETTING, be sure to turn off the power and turn it on again.

9. FUNCTION SETTING

This procedure changes the function settings used to control the indoor unit according to the installation conditions.

Incorrect settings can cause the indoor unit to malfunction.

This procedure should be performed by authorized installation or service personnel only.

Perform the "FUNCTION SETTING" according to the installation conditions using the remote controller.

- Refer to the indoor unit installation manual for details on the function numbers and setting numbers.
- Prepare for setting of indoor unit referring to installation manual of indoor unit before start of functional setting.

Start of Function setting mode

- (1) Press the "▲ TEMP." button, "▼ TEMP." button and "FAN SPEED" for more than 5 seconds simultaneously. Then shift to Function setting mode.

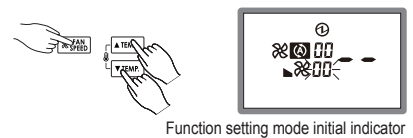

- (2) Press the "▲ TEMP." button or "▼ TEMP." button and select the Remote controller address (Select the relevant indoor unit). Then press "FAN SPEED" button.

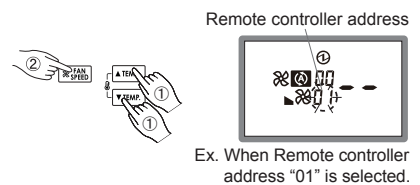

Function number and setting number setting

- (3) "Function number" indicator blinks. Then display Number by pressing the "▲ TEMP." button or "▼ TEMP." button.

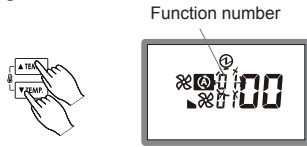

- (4) When the "Setting number" blinks by pressing the "FAN SPEED" button set the Setting number by pressing the "▲ TEMP." button or "▼ TEMP." button.

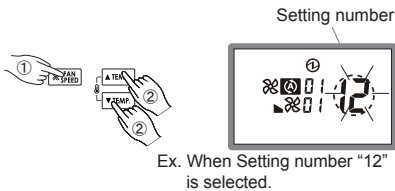

- (5) Fix the setting by pressing the "START/STOP" button.
(Data is transferred to the indoor unit).

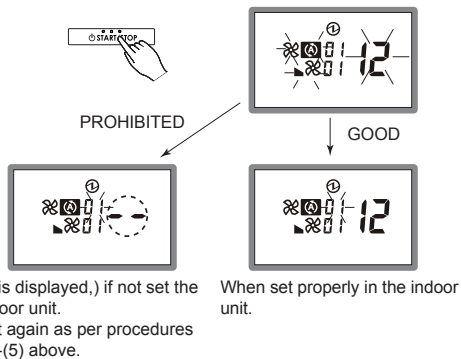

Completion of address setting mode

- (6) Function setting mode is released and returns to normal indicator if the "▲ TEMP." button, "▼ TEMP." button and "FAN SPEED" button are pressed for more than 5 seconds simultaneously.

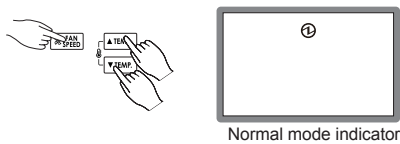

- * Function setting mode is released automatically if no key is pressed for 60 seconds even the above buttons are not pressed.
(Switch to Function setting mode as per procedure (1) above.)

- (7) After completing the FUNCTION SETTING, be sure to turn off the power and turn it on again.

10. TEST RUN

This unit does not activate the test run. Test run can be activated by the other remote controllers.

Note:

- When "01" is indicated on temperature indicator, it means under test run.
- When "02" is indicated on temperature indicator, it means under maintenance.
Indoor unit cannot be operated.

11. FILTER LAMP RESET

Some indoor unit models are equipped with a filter lamp in the indoor unit display to indicate when it is time to clean the air filters.

Press the "FAN SPEED" button for 2 seconds or more.

The indoor unit filter lamp will go off and the filter indicator will disappear.



12. ERROR CODE

If there is a problem with the air conditioner, it will stop running and "Er" will be displayed.

If an error occurs, it appears automatically on the display as shown below.

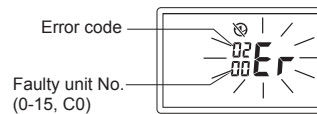

If "Er" is displayed, immediately contact authorized service personnel.
Do not use the operation below if an error has occurred.

- When 0-15 is indicated on the Faulty unit No., error has occurred at the indoor unit. Refer to the indoor unit installation manual.

| Faulty unit No. | Error code | Contents |
|-----------------|------------|---|
| 00 | 12 | Indoor unit ↔ remote controller communication error |
| 00 | 15 | Incompatible indoor unit is connected |