

SPLIT TYPE
AIR CONDITIONER
DUCT TYPE (50Hz)

SERVICE MANUAL

Indoor unit Outdoor unit
ARYG60LHTA AOYG60LATT



CONTENTS

SPECIFICATIONS	1
DIMENSIONS	2
REFRIGERANT SYSTEM DIAGRAM ...	4
CIRCUIT DIAGRAM	5
INDOOR PCB CIRCUIT DIAGRAM	6
OUTDOOR PCB CIRCUIT DIAGRAM ..	10
ERROR DETECTION	17
PARTS (INDOOR UNIT)	21
PARTS (OUTDOOR UNIT)	24
ACCESSORIES	27

SPECIFICATIONS

ELECTRICAL DATA

TYPE	Cooling & Heating	
INDOOR UNIT	ARYG60LHTA	
OUTDOOR UNIT	AOYG60LATT	
COOLING CAPACITY	15.0 kW	
HEATING CAPACITY	18.0 kW	
POWER SOURCE	400 V, 50 Hz, 3 phase, 4 W	
RUNNING CURRENT	Cooling	6.9 A
	Heating	7.6 A
INPUT WATTS	Cooling	4.70 kW
	Heating	5.15 kW
E.E.R.	Cooling	3.19 kW/kW
C.O.P.	Heating	3.50 kW/kW
MOISTURE REMOVAL	2.0 L/hr	
AIRCIRCULATION INDOOR	3,550 m ³ /h	
AIRCIRCULATION OUTDOOR	Cooling	6,900 m ³ /h
	Heating	7,300 m ³ /h
MAXIMUM CURRENT	12.5 A	

FAN MOTOR

INDOOR UNIT, Discrimination	MFG-54AVN	
INDOOR UNIT Fan 1 / Fan 2	High	1,090 r.p.m. / 1,050 r.p.m.
	Medium	900 r.p.m. / 860 r.p.m.
	Low	780 r.p.m. / 740 r.p.m.
OUTDOOR UNIT, Discrimination	MFE-54VVT	
OUTDOOR UNIT Cooling	Upper fan	900 r.p.m.
	Lower fan	800 r.p.m.
OUTDOOR UNIT Heating	Upper fan	900 r.p.m.
	Lower fan	900 r.p.m.

NOISE LEVEL

INDOOR UNIT	High	45 dB
	Medium	40 dB
	Low	36 dB
OUTDOOR UNIT	Cooling	56 dB
	Heating	58 dB

COMPRESSOR AND REFRIGERANT

TYPE	Hermetic type, Inverter, 4 poles, 3 phase, DC motor, Twin Rotary	
DISCRIMINATION	DA422A3F-29ZAD	
WEIGHT (with oil)	23.0 kg	
REFRIGERANT TYPE	R410A	
PRECHARGED REFRIGERANT	3,450 g	
MAX PIPE HEIGHT	30 m	
	Pipe length	30 m
		3,450 g
FULL CHARGE	45 m	
	60 m	
	4,950 g	
ADDITIONAL CHARGE	75 m	
	5,700 g	
	50 g/m	

DIMENSIONS

INDOOR UNIT	H x W x D	425 x 1,250 x 490 mm
OUTDOOR UNIT	H x W x D	1,290 x 900 x 330 mm

WEIGHT

INDOOR UNIT	Shipping / Net	61 kg / 54 kg
OUTDOOR UNIT	Shipping / Net	113 kg / 104 kg

DIMENSIONS

INDOOR UNIT
(Unit : mm)

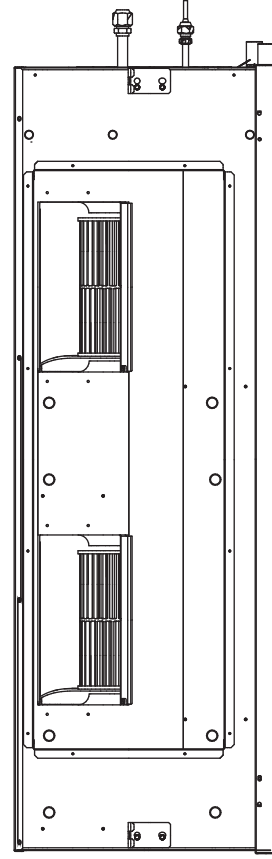
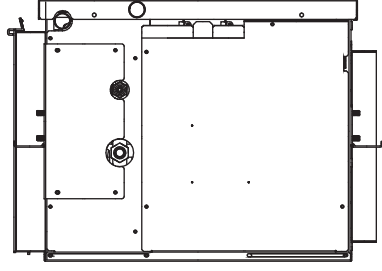
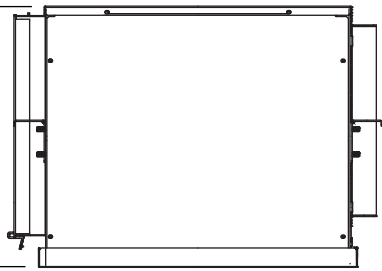
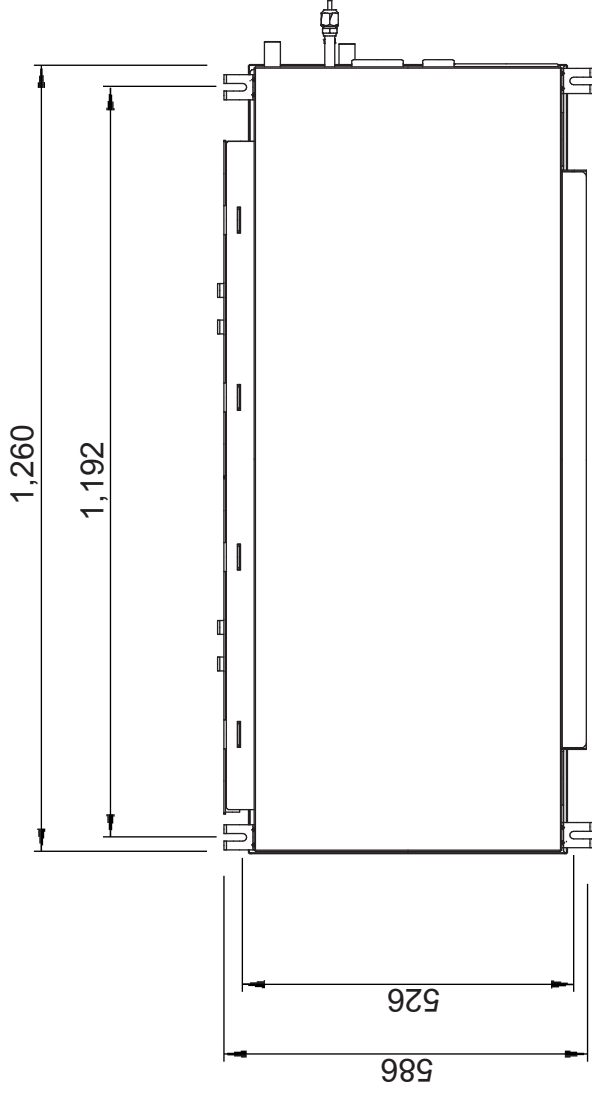
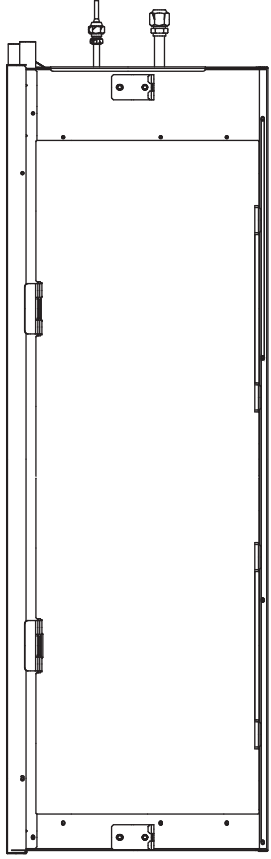

Drain hose diameter
Inside : 23.4 mm
Outside : 25.4 mm

OUTDOOR UNIT
(unit : mm)

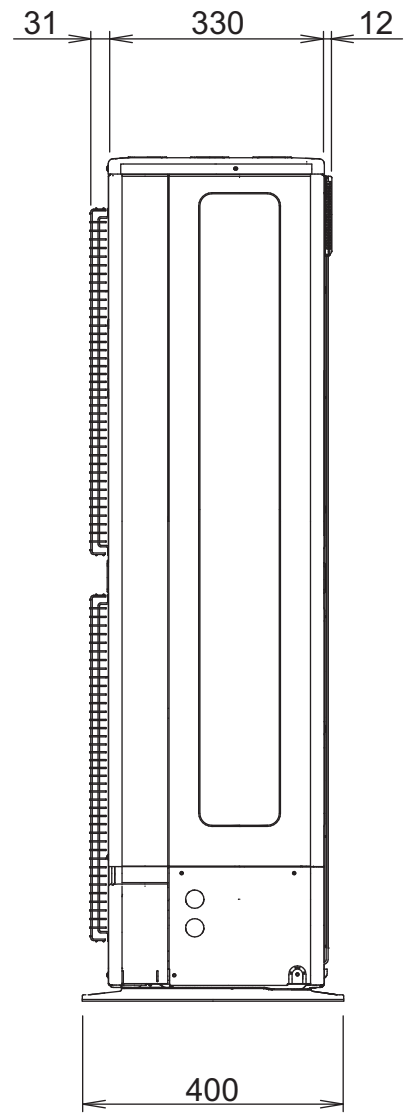
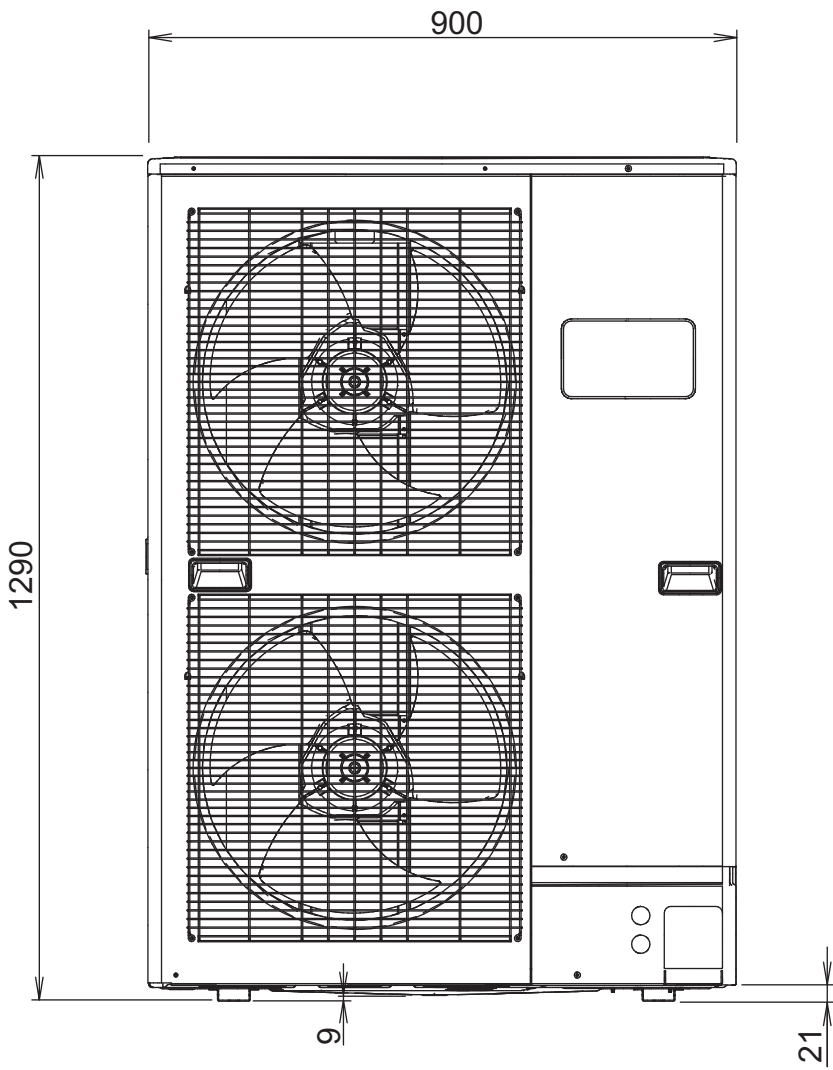
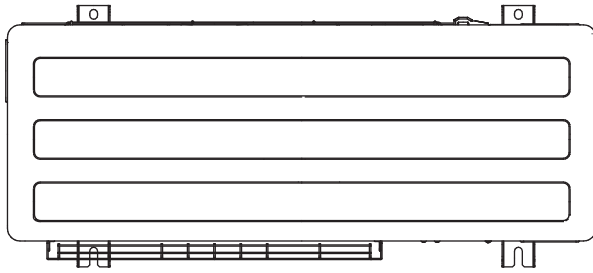

air flow
↑

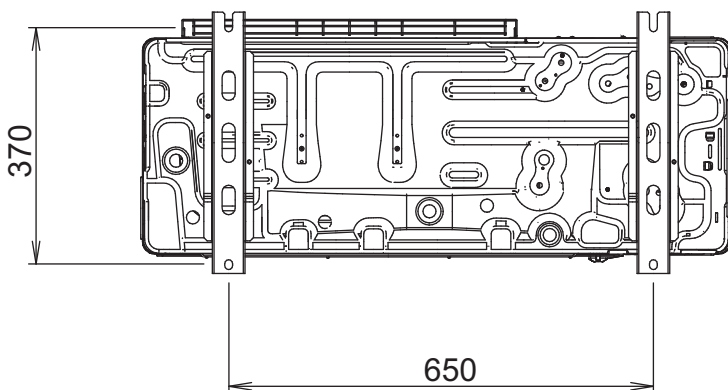

REFRIGERANT SYSTEM DIAGRAM

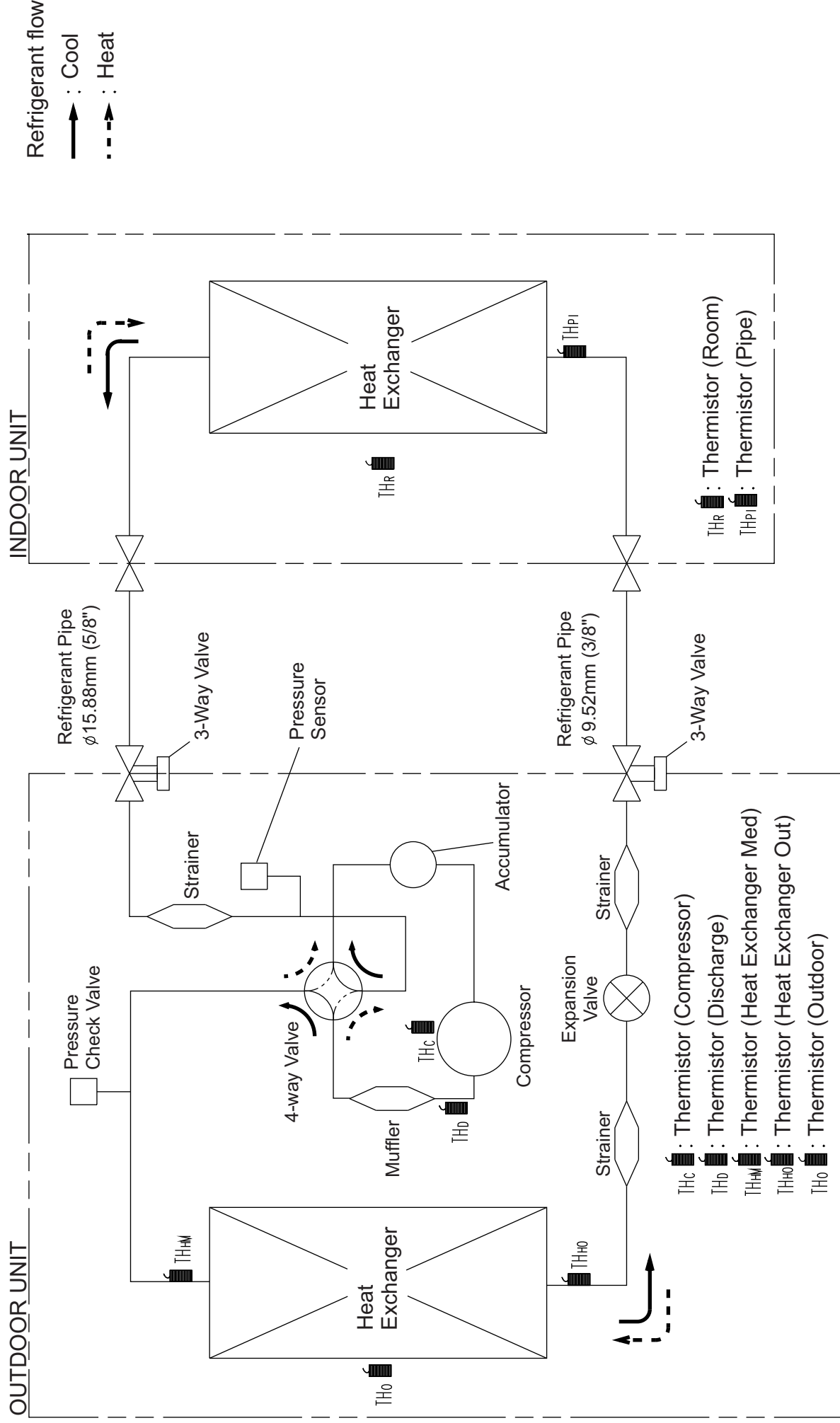

CIRCUIT DIAGRAM

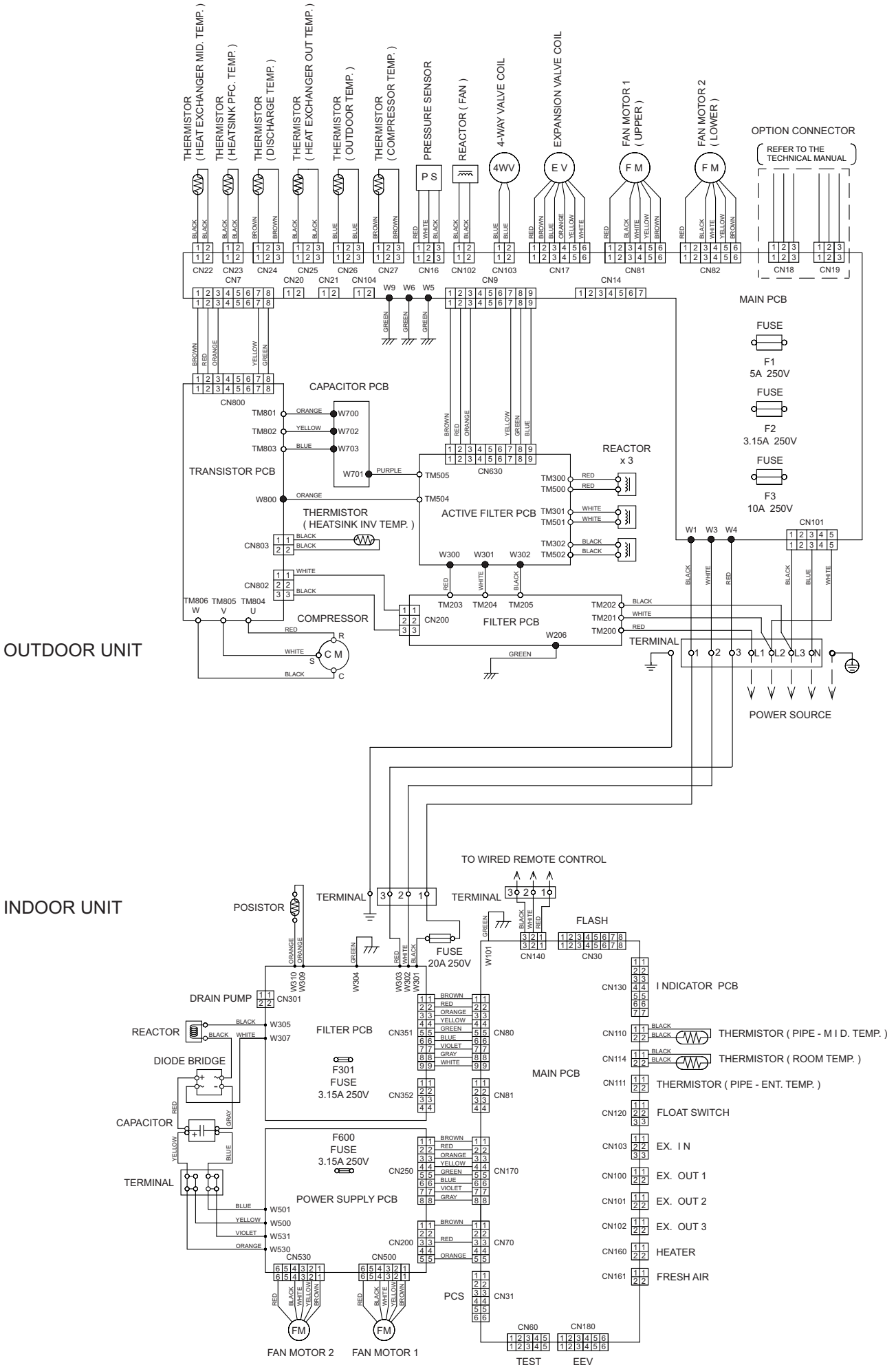

INDOOR PCB CIRCUIT DIAGRAM

CONTROL UNIT
EZ-01220HSE

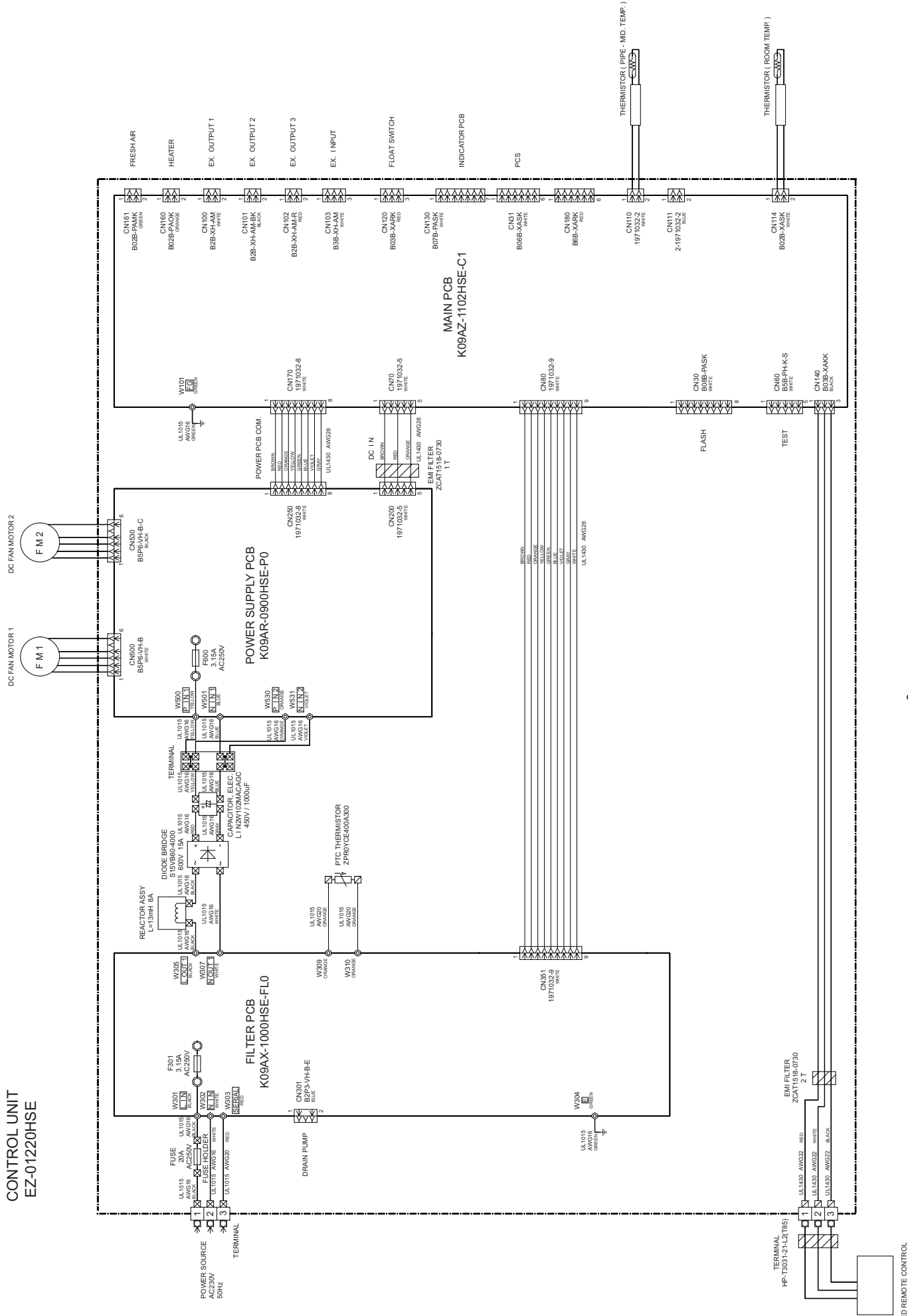

INDOOR UNIT
MAIN PCB
K09AZ-1102HSE-C1

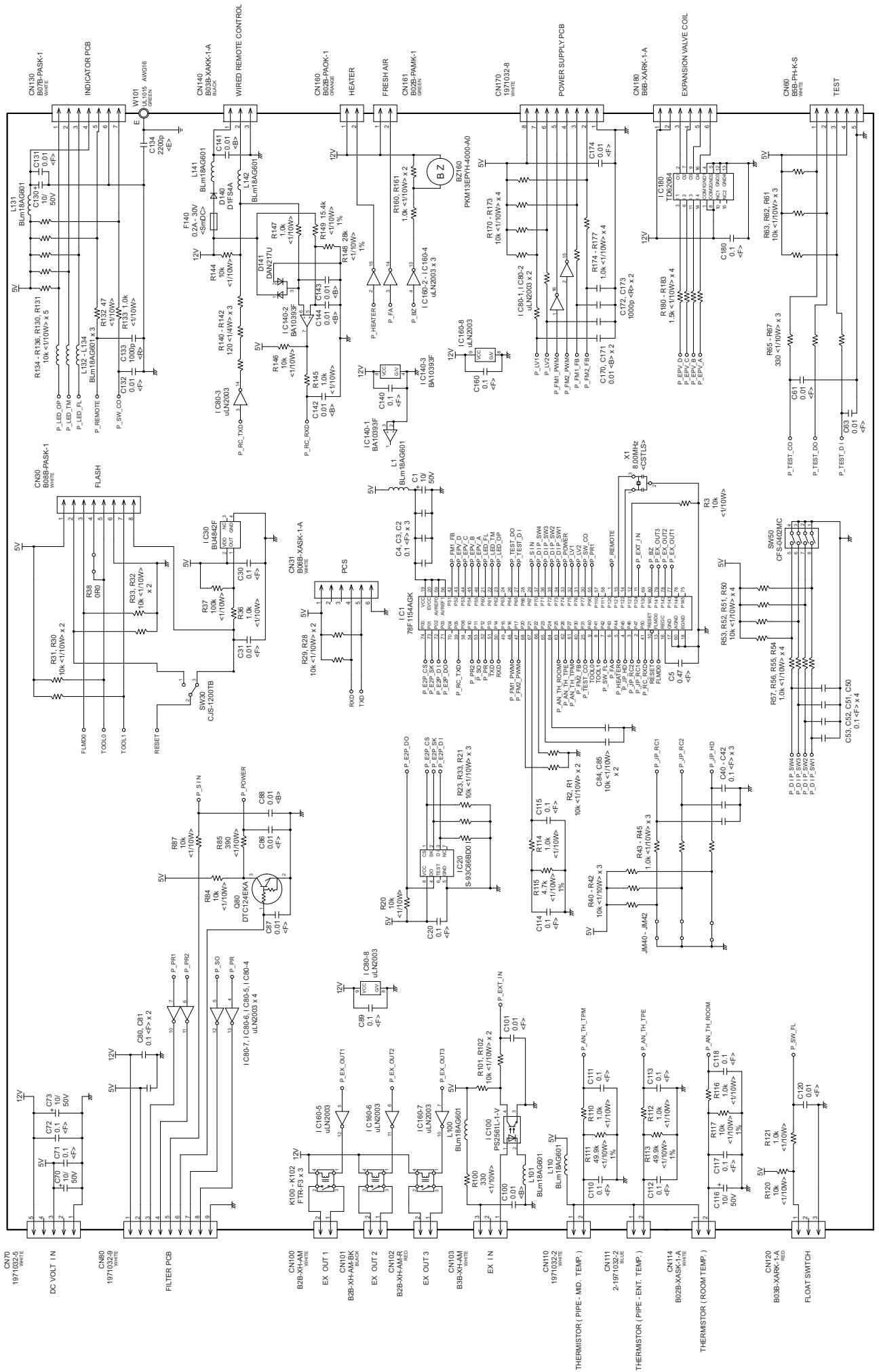

INDOOR UNIT
POWER SUPPLY PCB
K09AR-0900HSE-PO

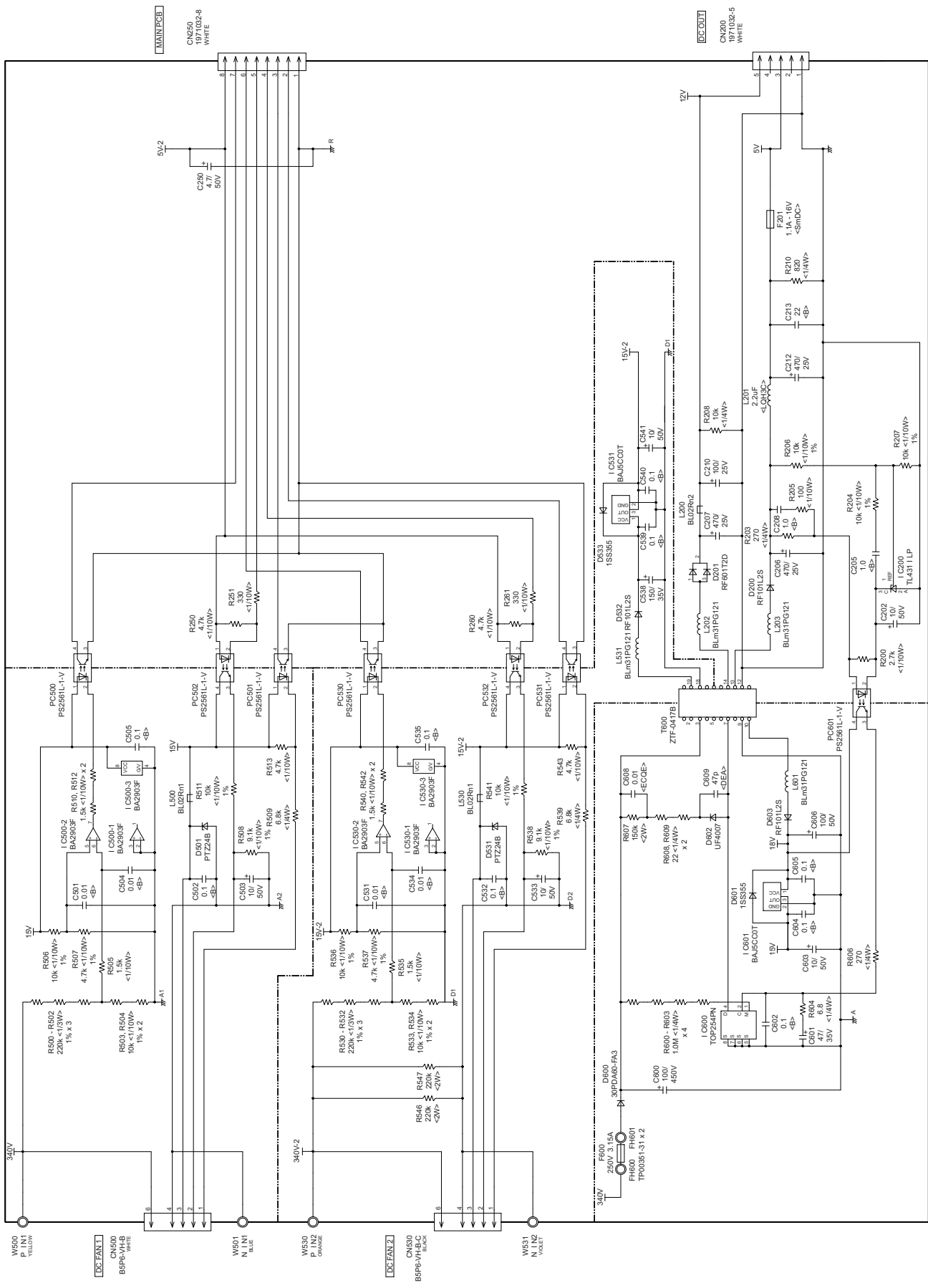

MAIN PCB
CN950
1071032-8
WHITE

DC FAN 1
CN800
1971032-5
WHITE

DC FAN 1
CN800
1971032-5
WHITE

DC FAN 2
CN830
B596-VH2C
BLACK

INDOOR UNIT
FILTER PCB
K09AX-1000HSE-FLO

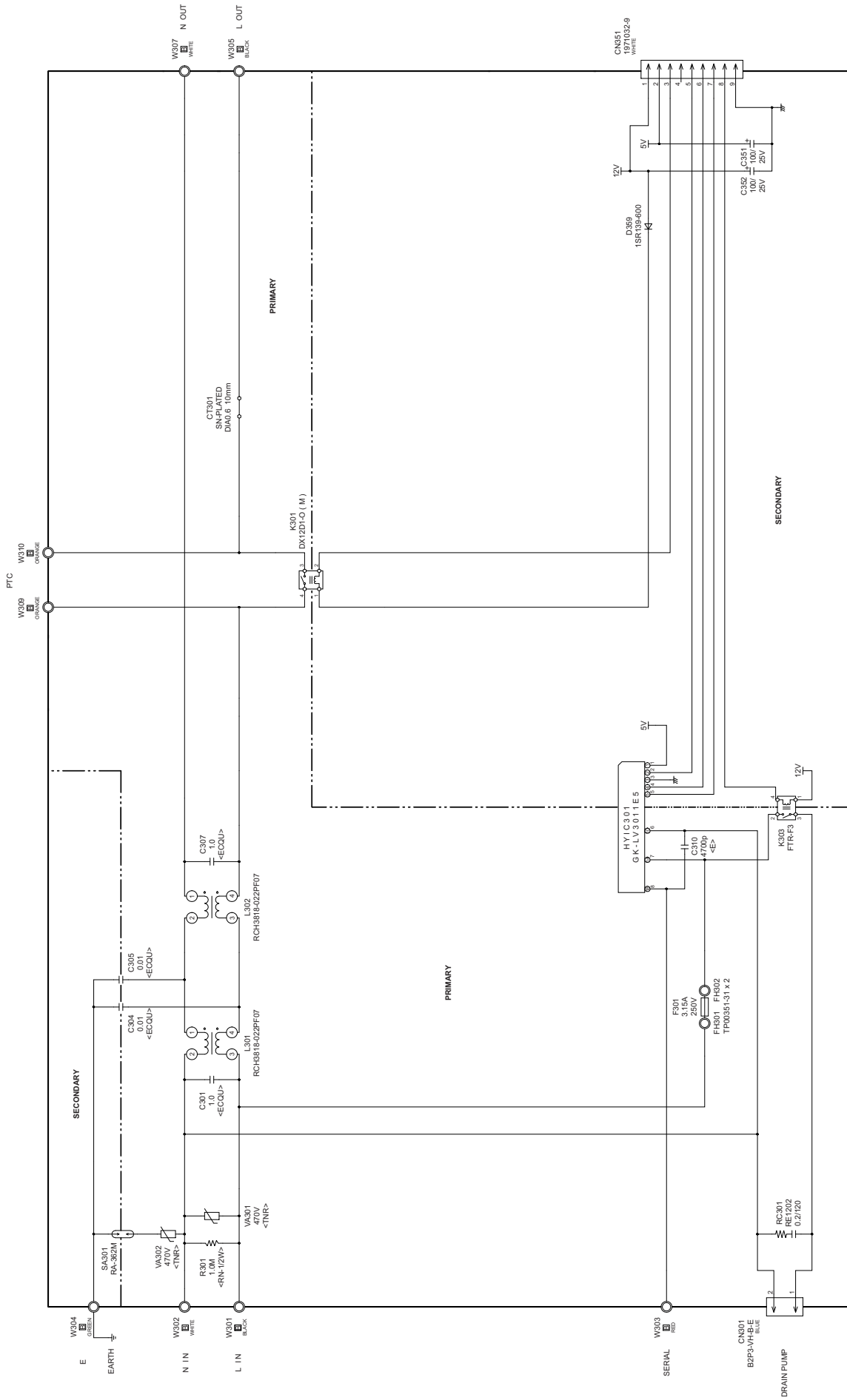

OUTDOOR PCB CIRCUIT DIAGRAM

INVERTER ASSEMBLY EZ-01123HUE

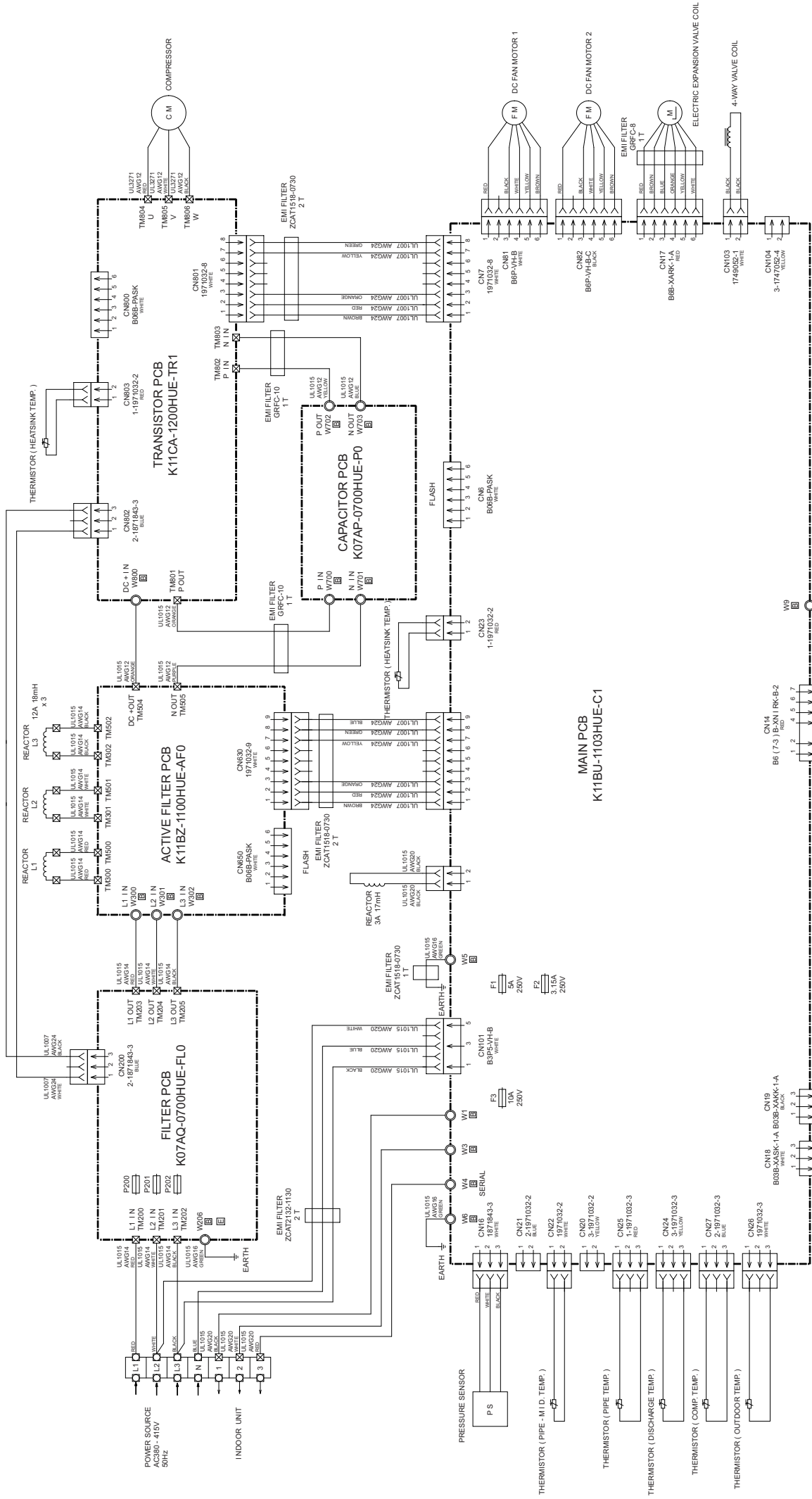

MAIN PCB K11BU-1103HUE-C1

OUTDOOR UNIT MAIN PCB K11BU-1103HUE-C1

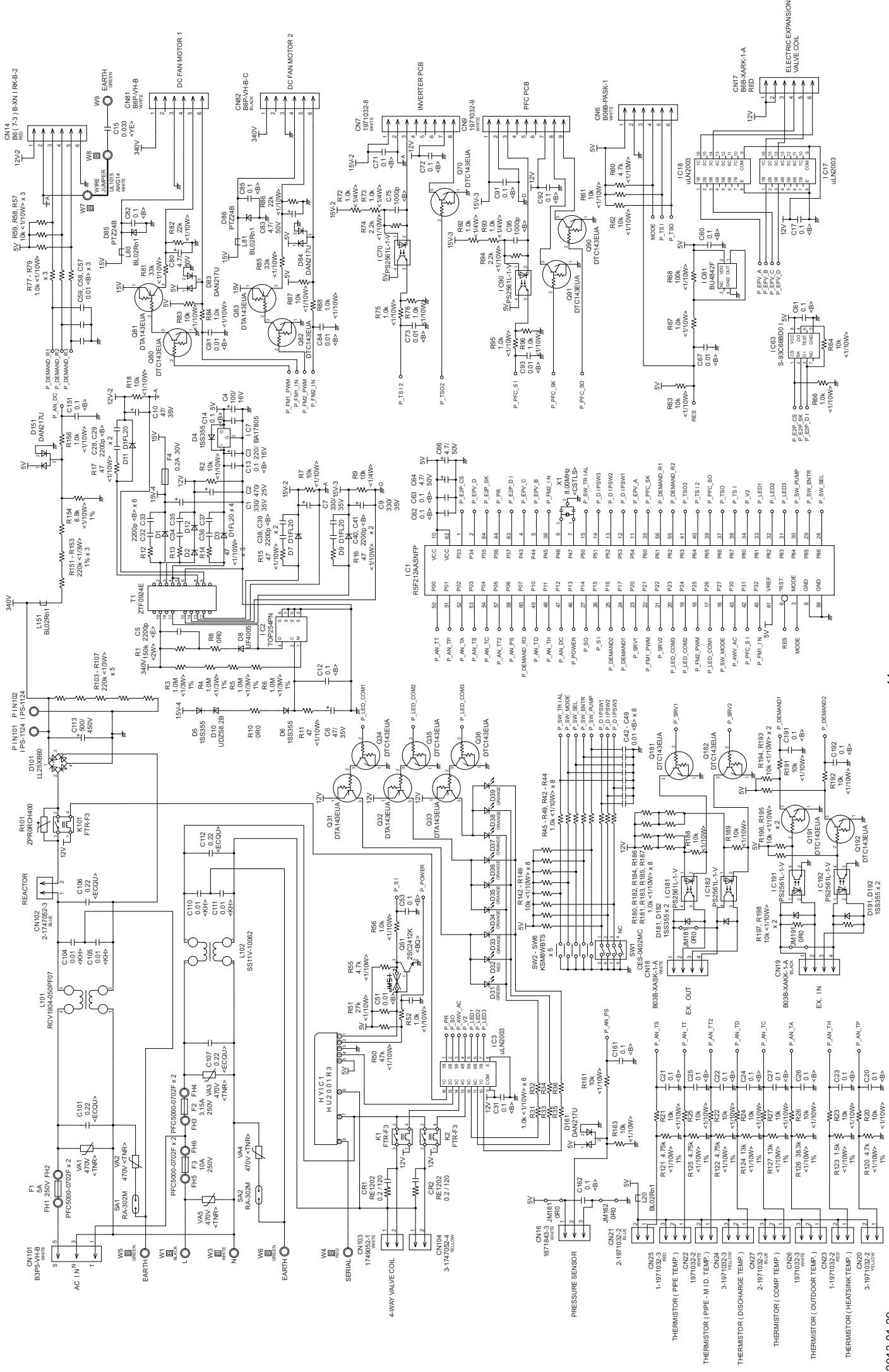

OUTDOOR UNIT
TRANSISTOR PCB
K11CA-1200HUE-TR-1

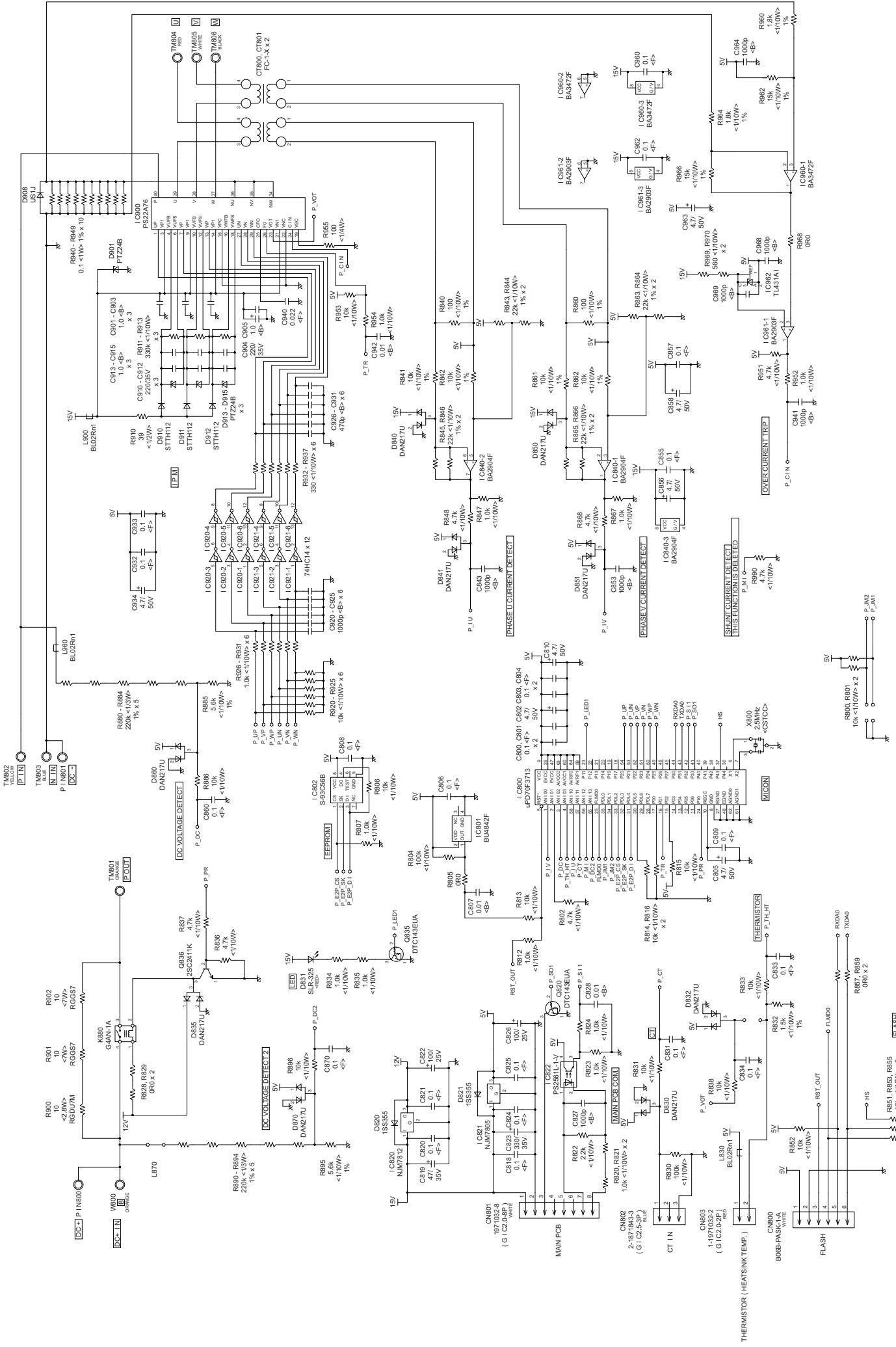

OUTDOOR UNIT
ACTIVE FILTER PCB - 1
K-11BZ-1100HUE-AF0

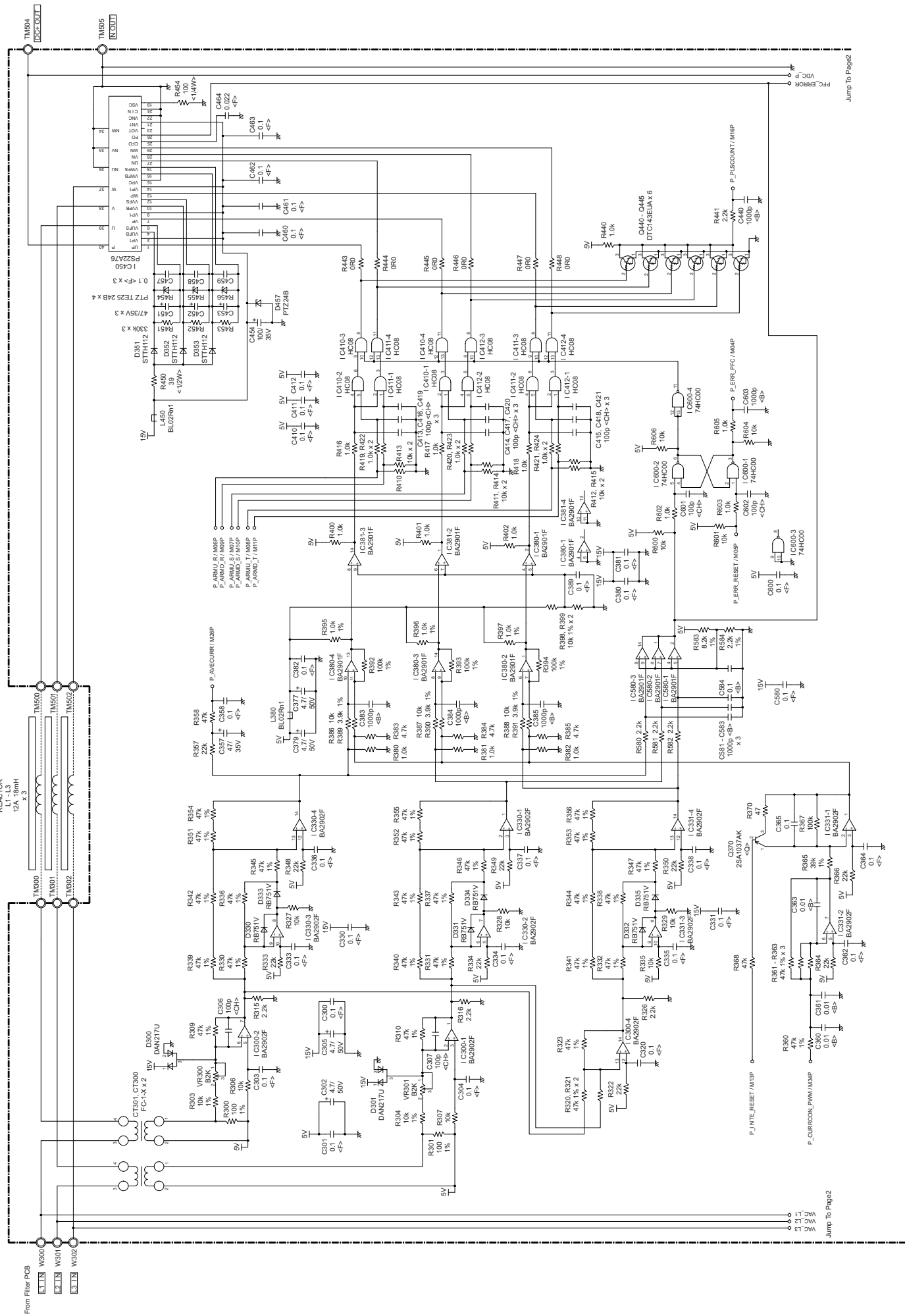

OUTDOOR UNIT
 FILTER PCB
 K07AQ-0700HUE-FL0

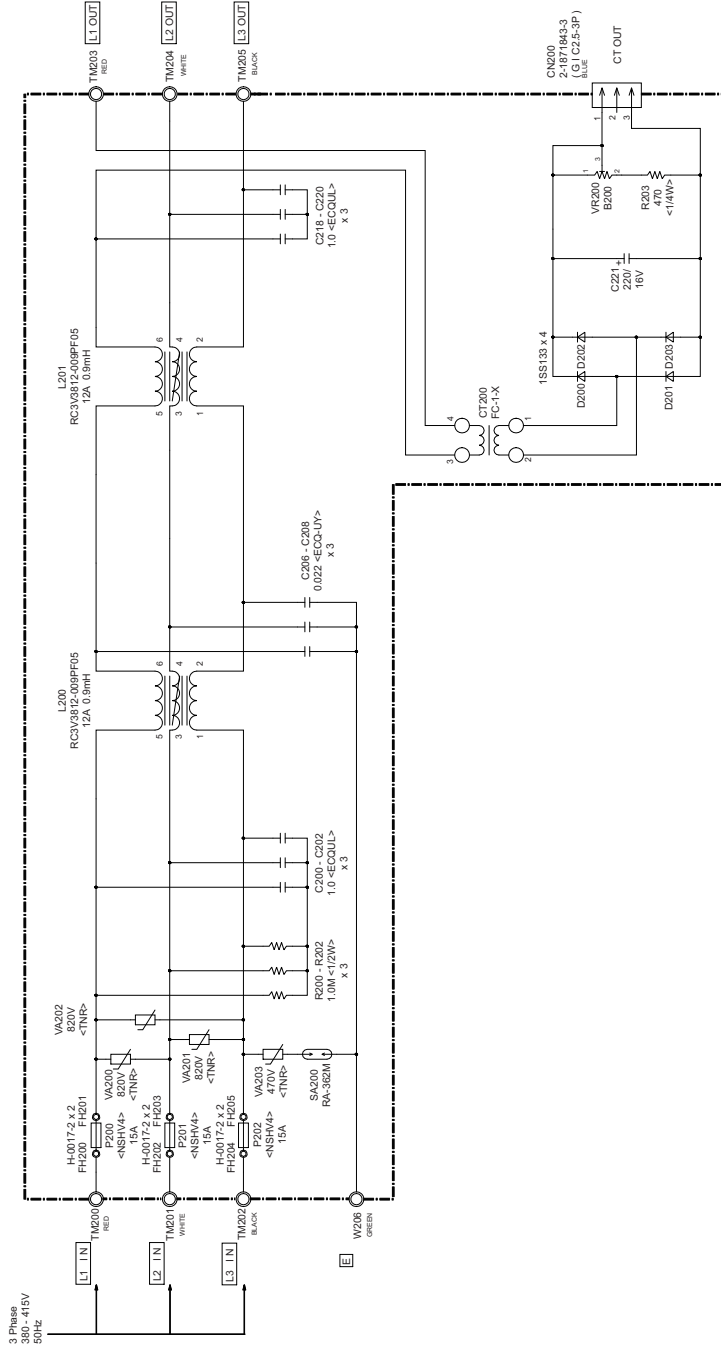

OUTDOOR UNIT
CAPACITOR PCB
K07AP-0700HUE-P0

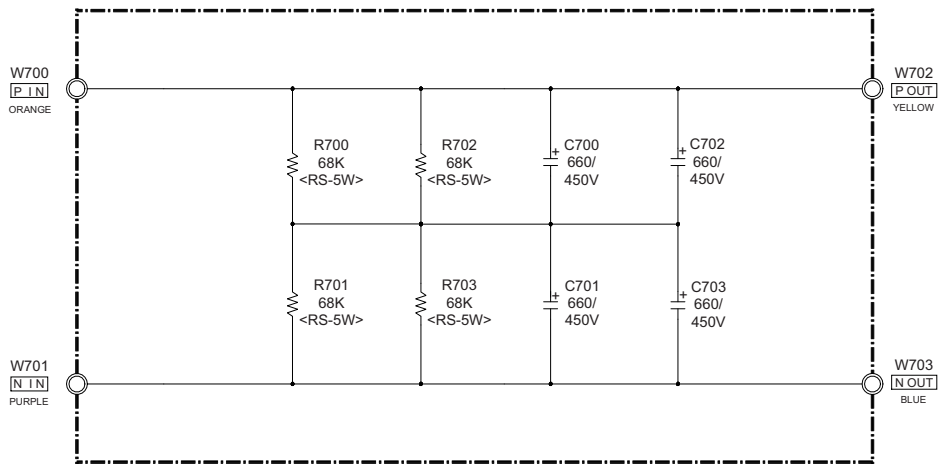

ERROR DETECTION

INDOOR UNIT and WIRED REMOTE CONTROL

If you use a wireless remote control, the lamp on the photo detector unit will output error codes by way of blinking patterns.
If you use a wired type remote control, error codes will appear on the remote control display. See the lamp blinking patterns and error codes in the table. An error display is displayed only during running.

Remote control

This is possible only on a wired remote control. If an error occurs, the following display will be shown. ("Er" will appear in the set room temperature display.)

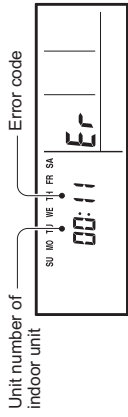

EX. Self-diagnosis

- : 0.5s on / 0.5s off
- ◇ : 0.1s on / 0.1s off
- () : Number of flashing

Indoor unit			Wired remote control	Description
OPERATION lamp (green)	TIMER lamp (orange)	ECONOMY lamp (green)		
● (1)	● (1)	◇	11	Serial communication error
● (1)	● (2)	◇	12	Wired remote control communication error
● (1)	● (5)	◇	15	Check run unfinished
● (2)	● (1)	◇	21	Unit number or Refrigerant circuit address setting error [Simultaneous Multi]
● (2)	● (2)	◇	22	Indoor unit capacity error
● (2)	● (3)	◇	23	Combination error
● (2)	● (4)	◇	24	• Connection unit number error (indoor slave unit) [Simultaneous Multi] • Connection unit number error (indoor unit or branch unit) [Flexible Multi]
● (2)	● (7)	◇	27	Master unit, slave unit set-up error [Simultaneous Multi]
● (3)	● (1)	◇	31	Power supply interruption error
● (3)	● (2)	◇	32	Indoor unit PCB model information error
● (3)	● (5)	◇	35	Manual auto switch error
● (4)	● (1)	◇	41	Inlet air temp. sensor error
● (4)	● (2)	◇	42	Indoor unit Heat Ex. Middle temp. sensor error
● (5)	● (1)	◇	51	Indoor unit fan motor error
● (5)	● (3)	◇	53	Drain pump error
● (5)	● (7)	◇	57	Damper error
● (5)	● (15)	◇	5U	Indoor unit error
● (6)	● (2)	◇	62	Outdoor unit main PCB model information error or communication error
● (6)	● (3)	◇	63	Inverter error
● (6)	● (4)	◇	64	Active filter error, PFC circuit error
● (6)	● (5)	◇	65	Trip terminal Error
● (6)	● (10)	◇	6A	Display PCB microcomputers communication error

Indoor unit			Wired remote control	Description
OPERATION lamp (green)	TIMER lamp (orange)	ECONOMY lamp (green)		
● (7)	● (1)	◇	71	Discharge temp. sensor error
● (7)	● (2)	◇	72	Compressor temp. sensor error
● (7)	● (3)	◇	73	Outdoor unit Heat Ex. liquid temp. sensor error
● (7)	● (4)	◇	74	Outdoor temp. sensor error
● (7)	● (5)	◇	75	Suction Gas temp. sensor error
● (7)	● (6)	◇	76	• 2-way valve temp. sensor error • 3-way valve temp. sensor error
● (7)	● (7)	◇	77	Heat sink temp. sensor error
● (8)	● (2)	◇	82	• Sub-cool Heat Ex. gas inlet temp. sensor error • Sub-cool Heat Ex. gas outlet temp. sensor error
● (8)	● (3)	◇	83	Liquid pipe temp. sensor error
● (8)	● (4)	◇	84	Current sensor error
● (8)	● (6)	◇	86	• Discharge pressure sensor error • Suction pressure sensor error • High pressure switch error
● (9)	● (4)	◇	94	Trip detection
● (9)	● (5)	◇	95	Compressor rotor position detection error (permanent stop)
● (9)	● (7)	◇	97	Outdoor unit fan motor error
● (9)	● (8)	◇	98	Outdoor unit fan motor 2 error
● (9)	● (9)	◇	99	4-way valve error
● (9)	● (10)	◇	9A	Coil (expansion valve) error
● (10)	● (1)	◇	A1	Discharge temp. error
● (10)	● (3)	◇	A3	Compressor temp. error
● (10)	● (4)	◇	A4	High pressure error
● (10)	● (5)	◇	A5	Low pressure error
● (13)	● (2)	◇	J2	Branch boxes error [Flexible Multi]

OUTDOOR UNIT

TEST RUN

⚠ CAUTION

Always turn on the power 6 hours prior to the start of the operation in order to protect the compressor.

1. Check items before performing the test run

Make sure to perform the test run.

Before performing the test run, be sure to check the following points.

- (1) Is gas leaking?
Check connection of each pipe (flare connection part, brazing part).
- (2) Is a breaker installed to the power cable of the outdoor unit ?
- (3) Has each cable been securely connected to the terminal according to the specifications ?
- (4) Are the 3-way valves (gas pipes and liquid pipes) of the outdoor units open?
- (5) Has the power been supplied to the unit for at least 6 hours ?
- (6) Has the necessary local setting been done ?
- (7) Check insulation resistance of 1 MΩ or more using a 500V mega tester.

If no problems are found with the above items, perform the test run according to "Test run method".

If any problems are found, immediately resolve the problem and re-check the items.

2. Test run method

⚠ CAUTION

If the test run is performed for 1 outdoor unit in a group control system installation, the test run will also be performed for the other units. Therefore, make sure that all of the units have been installed before starting a test run.
(Group control system installation described in "SPECIAL INSTALLATION METHODS" in the installation manual of the indoor unit.)

Operate [ENTER] (TEST RUN) switch on the display board by the following procedure.

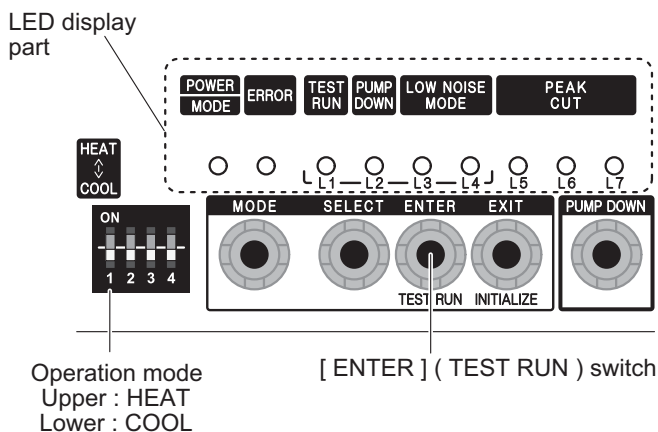

2.1. Operating procedures for the test run

- (1) Check the 3-way valves (both at the liquid side and gas side) are opened.
- (2) Set the operation mode to "COOL" or "HEAT".

POWER MODE	ERROR	TEST RUN (L1)	PUMP DOWN (L2)	LOW NOISE (L3) (L4)		PEAK CUT (L5) (L6) (L7)		
●	○	○	○	○	○	○	○	○

In the first test run, be sure to set the operation mode to "COOL".

The operation mode cannot be switched between "COOL" and "HEAT" during the test run. To switch the operation mode between "COOL" and "HEAT", stop the test run, switch the operation mode, and then start the test run again.

- (3) Press [ENTER] (TEST RUN) switch for more than 3 seconds.

POWER MODE	ERROR	TEST RUN (L1)	PUMP DOWN (L2)	LOW NOISE (L3) (L4)		PEAK CUT (L5) (L6) (L7)		
●	○	●	○	○	○	○	○	○

"TEST RUN" LED will light on.

If the compressor is operating at starting the test run, the compressor will stop and, after a while, the test run will start.

Either of the above "LOW NOISE" or "PEAK CUT" will light on during the test run if local setting function is selected.

- (4) Confirm operating status.
- (5) Press [ENTER] (TEST RUN) switch again.

POWER MODE	ERROR	TEST RUN (L1)	PUMP DOWN (L2)	LOW NOISE (L3) (L4)		PEAK CUT (L5) (L6) (L7)		
●	○	○	○	○	○	○	○	○

"TEST RUN" LED lights off, and TEST RUN stops.

Test run will finish after about 60 minutes automatically. At the same time, "TEST RUN" LED will light off.

Test run may be stopped before operating for 60 minutes if an error occurs after a starting test run.

OUTDOOR UNIT ERROR CODE DISPLAY

Display when an error occurs

POWER MODE	ERROR	TEST RUN (L1)	PUMP DOWN (L2)	LOW NOISE (L3) (L4)		PEAK CUT (L5) (L6) (L7)		
●	Blinks (Hi-speed)	○	○	○	○	○	○	○

Check that the ERROR LED blinks,
and then short-press the [ENTER] switch once.
The number of blinks of the LED indicates the type of error.

Display mode ● : ON
○ : OFF
◆ : Blink (0.5s ON / 0.5s OFF)
() : Number of flashing

Error code check table

POWER MODE	ERROR	TEST RUN (L1)	PUMP DOWN (L2)	LOW NOISE (L3) (L4)		PEAK CUT (L5) (L6) (L7)			Description
◆(2)	●	◆(1)	◆(1)	○	○	○	●	●	Serial forward transmission error immediately after operation
◆(2)	●	◆(1)	◆(1)	○	○	●	○	○	Serial forward transmission error during operation
◆(2)	●	◆(2)	◆(2)	○	○	○	○	●	Indoor unit capacity error
◆(2)	●	◆(5)	◆(15)	○	○	○	○	●	Indoor unit error
◆(2)	●	◆(6)	◆(1)	○	○	○	○	●	Over voltage
◆(2)	●	◆(6)	◆(1)	○	○	○	●	●	Power supply frequency error
◆(2)	●	◆(6)	◆(2)	○	○	○	○	●	Outdoor unit PCB model information error
◆(2)	●	◆(6)	◆(2)	○	○	●	●	●	PFC communication error
◆(2)	●	◆(6)	◆(3)	○	○	○	○	●	Inverter error
◆(2)	●	◆(6)	◆(4)	○	○	●	●	●	PFC AD detection error
◆(2)	●	◆(6)	◆(4)	○	●	○	○	○	PFC hardware error
◆(2)	●	◆(6)	◆(5)	○	○	○	●	●	IPM error (Trip terminal L error)
◆(2)	●	◆(6)	◆(8)	○	○	○	●	○	Rush current limiting resistor temp rise protection
◆(2)	●	◆(7)	◆(1)	○	○	○	○	●	Discharge temp. sensor error
◆(2)	●	◆(7)	◆(2)	○	○	○	○	●	Compressor temp. sensor error
◆(2)	●	◆(7)	◆(3)	○	○	○	●	○	Heat Ex. middle temp. sensor error
◆(2)	●	◆(7)	◆(3)	○	○	○	●	●	Outdoor unit Heat Ex. liquid temp. sensor error
◆(2)	●	◆(7)	◆(4)	○	○	○	○	●	Outdoor temp. sensor error
◆(2)	●	◆(7)	◆(7)	○	○	○	○	●	Heat sink temp. sensor error
◆(2)	●	◆(7)	◆(7)	○	○	○	●	○	PFC heat sink temp. sensor error
◆(2)	●	◆(8)	◆(4)	○	○	○	○	●	Current sensor 1 error (stoppage permanently)
◆(2)	●	◆(8)	◆(6)	○	○	●	○	○	High pressure switch 1 error
◆(2)	●	◆(8)	◆(6)	○	○	●	●	○	Pressure sensor error
◆(2)	●	◆(9)	◆(4)	○	○	○	○	●	Trip detection (stoppage permanently)
◆(2)	●	◆(9)	◆(5)	○	○	○	○	●	Compressor motor control error (stoppage permanently)
◆(2)	●	◆(9)	◆(5)	○	○	●	○	●	Compressor motor loss of synchronization (stoppage permanently)
◆(2)	●	◆(9)	◆(7)	○	○	○	●	●	Outdoor unit fan motor 1 error (Duty error)
◆(2)	●	◆(9)	◆(8)	○	○	○	●	●	Outdoor unit fan motor 2 error (Duty error)
◆(2)	●	◆(9)	◆(9)	○	○	○	○	●	4-way valve error
◆(2)	●	◆(10)	◆(1)	○	○	○	○	●	Discharge temp. 1 error (stoppage permanently)
◆(2)	●	◆(10)	◆(3)	○	○	○	○	●	Compressor 1 temp. error (stoppage permanently)
◆(2)	●	◆(10)	◆(5)	○	○	○	○	●	Low pressure error

OUTDOOR UNIT

PUMP DOWN (Refrigerant collecting operation)

Perform the following procedures to collect the refrigerant when moving the indoor unit or outdoor unit

WARNING
Never touch electrical components such as the terminal blocks or reactor except the switch on the display board. It may cause a serious accident such as electric shock.

CAUTION
Perform the pump down operation before disconnecting any refrigerant pipe or electric cable.

Collect refrigerant from the service port or the 3-way valve if pump down cannot be performed.

In case of a group control system installation, do not turn the power off pump down is completed in all outdoor units.
(Group control system installation described in "SPECIAL INSTALLATION METHODS" in the installation manual of the indoor unit.)

Operate [PUMP DOWN] switch on the display board in the manner described below.

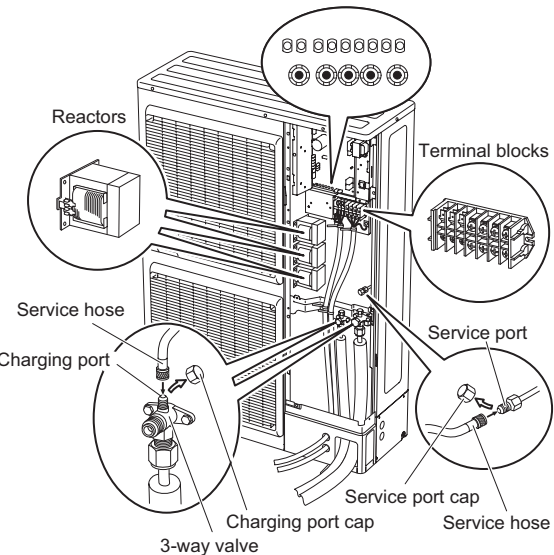
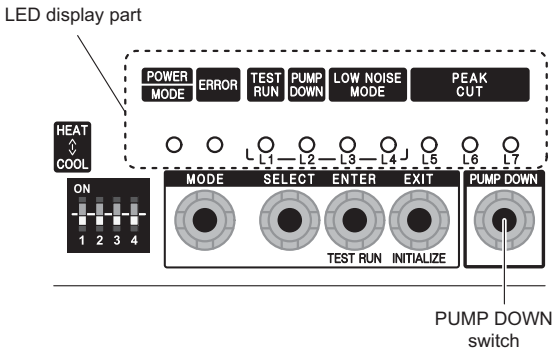

1. Preparation for pump down

Confirm that the power is off, and then open the service panel.

2. Pump down procedure

- (1) Check the 3-way valves (both at the liquid side and gas side) are opened.
- (2) Turn the power on.

POWER MODE	ERROR	TEST RUN (L1)	PUMP DOWN (L2)	LOW NOISE (L3) (L4)	PEAK CUT (L5) (L6) (L7)
●	○	○	○	○ ○	○ ○ ○

- (3) Press [PUMP DOWN] switch for 3 seconds or more after 3 minutes after power on.

POWER MODE	ERROR	TEST RUN (L1)	PUMP DOWN (L2)	LOW NOISE (L3) (L4)	PEAK CUT (L5) (L6) (L7)
●	○	○	●	○ ○	● ● ●

LED display lights on as shown in the above figure, and the fans and the compressor start operating.

If the [PUMP DOWN] switch is pressed while the compressor is operating, the compressor will stop, then start again in about 3 minutes.

- (4) LED display will change as shown below about 3 minutes after the compressor starts. Fully close the 3-way valve on the liquid pipe side at this stage.

POWER MODE	ERROR	TEST RUN (L1)	PUMP DOWN (L2)	LOW NOISE (L3) (L4)	PEAK CUT (L5) (L6) (L7)
●	○	○	●	○ ○	○ ● ●

If the valve on the liquid pipe side is not closed, the pump down cannot be performed.

- (5) When LED display changes as shown in the below figure, close the 3-way valve on the gas pipe side tightly.

POWER MODE	ERROR	TEST RUN (L1)	PUMP DOWN (L2)	LOW NOISE (L3) (L4)	PEAK CUT (L5) (L6) (L7)
●	○	○	●	○ ○	○ ○ ●

If the valve on the gas pipe side is not closed, refrigerant may flow into the piping after the compressor stops

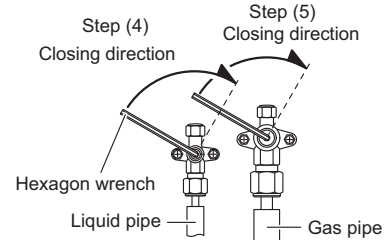

- (6) LED display changes after 1 minute as shown in the figure below

POWER MODE	ERROR	TEST RUN (L1)	PUMP DOWN (L2)	LOW NOISE (L3) (L4)	PEAK CUT (L5) (L6) (L7)
●	○	○	●	○ ○	○ ○ ○

Fans and compressor stop automatically.

If the pump down is successfully completed (the above LED display is shown), the outdoor unit remains stopped until the power is turned off.

- (7) Turn the power off.

POWER MODE	ERROR	TEST RUN (L1)	PUMP DOWN (L2)	LOW NOISE (L3) (L4)	PEAK CUT (L5) (L6) (L7)
○	○	○	○	○ ○	○ ○ ○

PUMP DOWN is completed.

(Note)

To stop pump down, press the [PUMP DOWN] switch again.

To start the pump down again after the compressor is automatically stopped due to an error, turn the power off and open the 3-way valves. Wait 3 minutes, turn the power on and start the pump down again.

When starting the operation after completion of the pump down, turn the power off, and then open the 3-way valves. Wait 3 minutes, turn the power on and perform a test run in the "COOL" operation mode.

PARTS

INDOOR UNIT

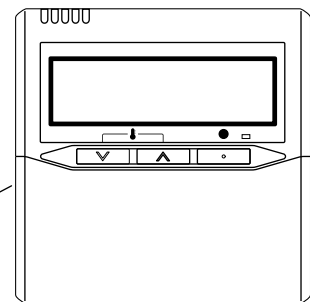
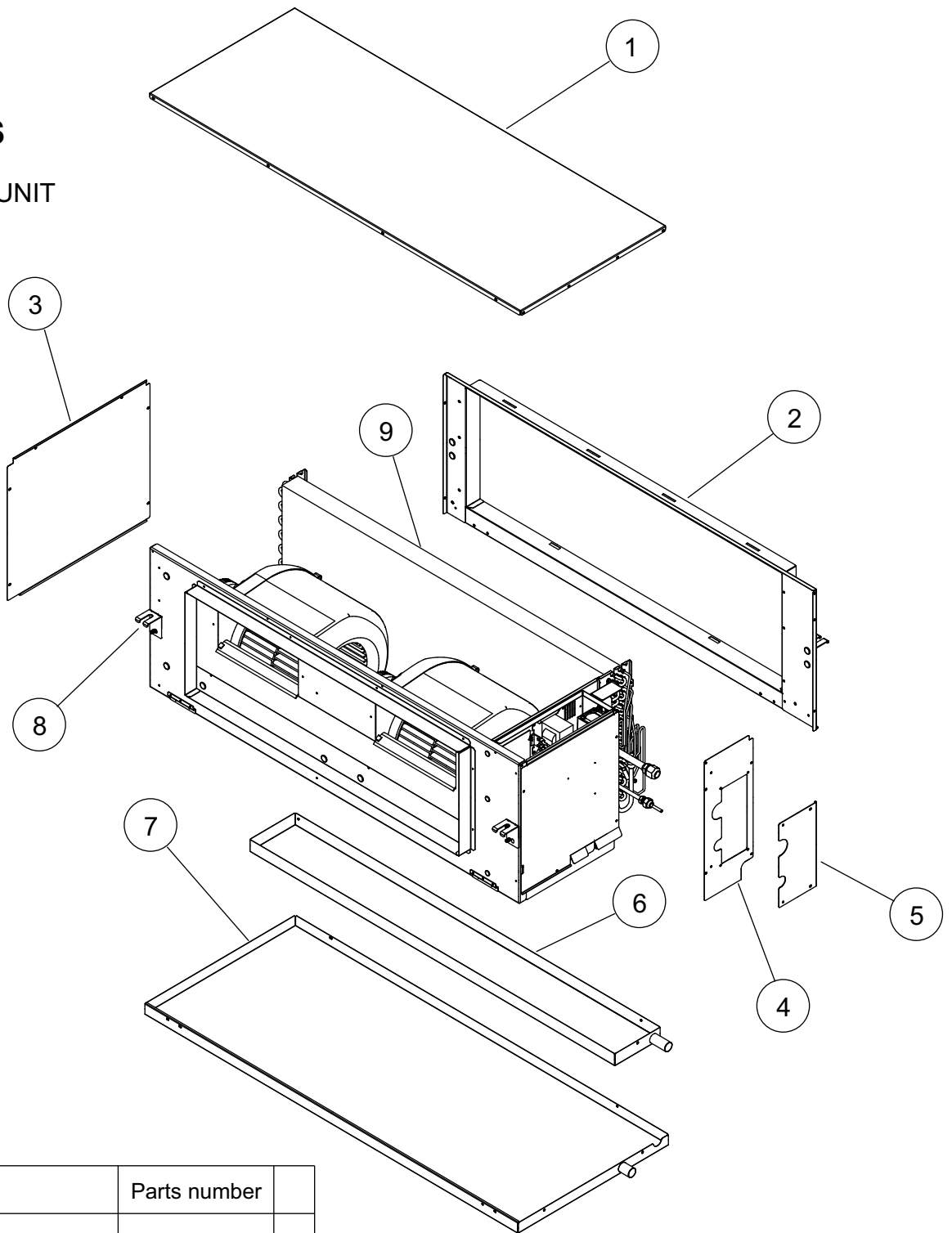

Ref.	Description	Parts number
1	Panel Top Sub Assy	9380191001
2	Panel Rear Sub Assy	9380205005
3	Panel Side R Sub Assy	9380194002
4	Panel Side L Sub Assy	9380203001
5	Pipe Panel	9380262008
6	Drain Pan Sub Assy	9380193005
7	S Drain Pan Sub Assy	9380204008
8	Hook	9372055007
9	Evaporator Total Assy	9380206002
10	Remote Control	9318593013

INDOOR UNIT

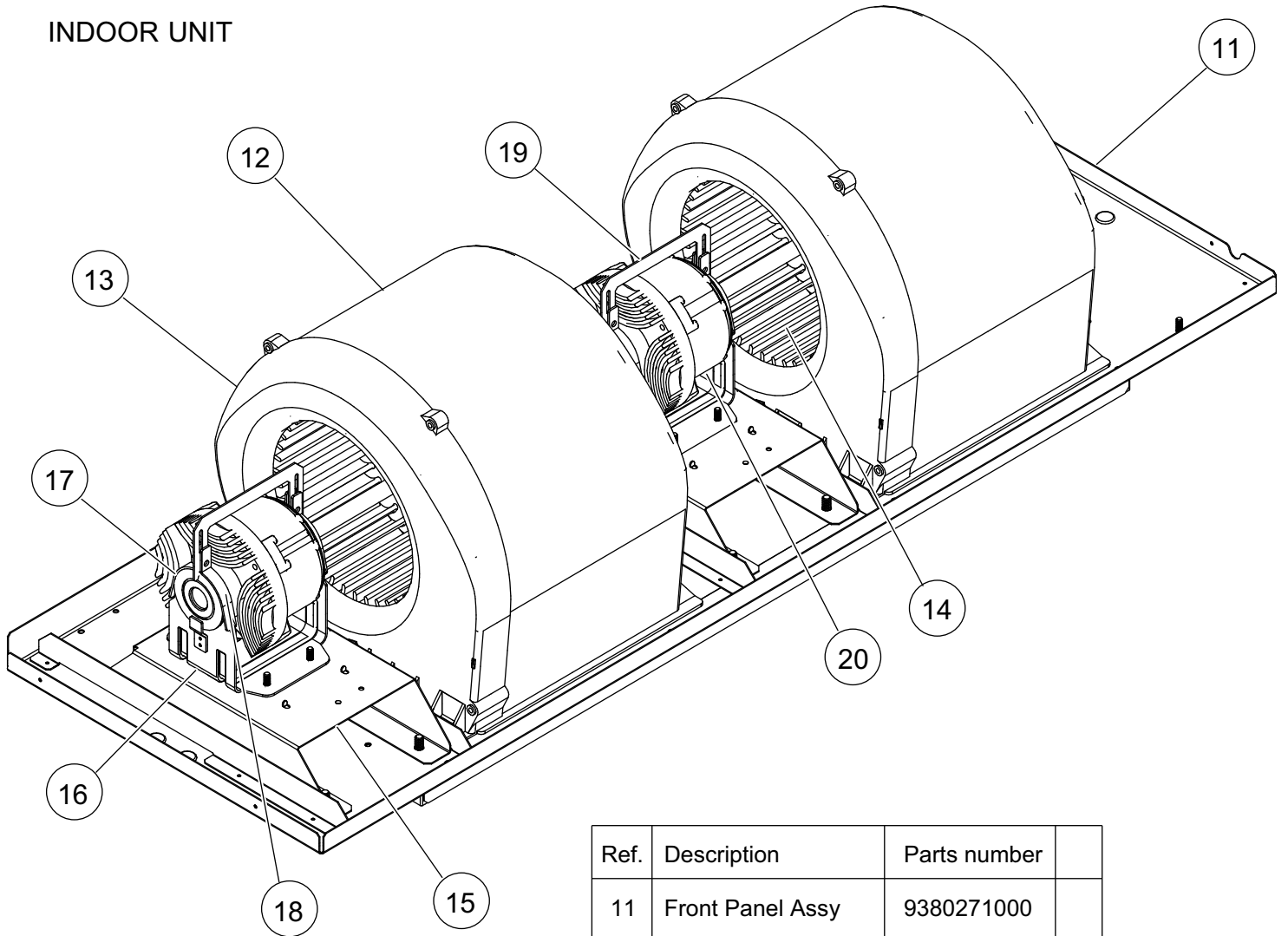

Ref.	Description	Parts number
11	Front Panel Assy	9380271000
12	Casing A	9372057018
13	Casing B	9372058015
14	Sirocco Fan	9372059029
15	Bracket Motor Assy	9372037010
16	Motor Mount Assy	9380216001
17	Motor Band	9378031012
18	Motor Band Assy	9378033016
19	Motor Band RFM	9378003019
20	Fan Motor	9603087012

INDOOR UNIT

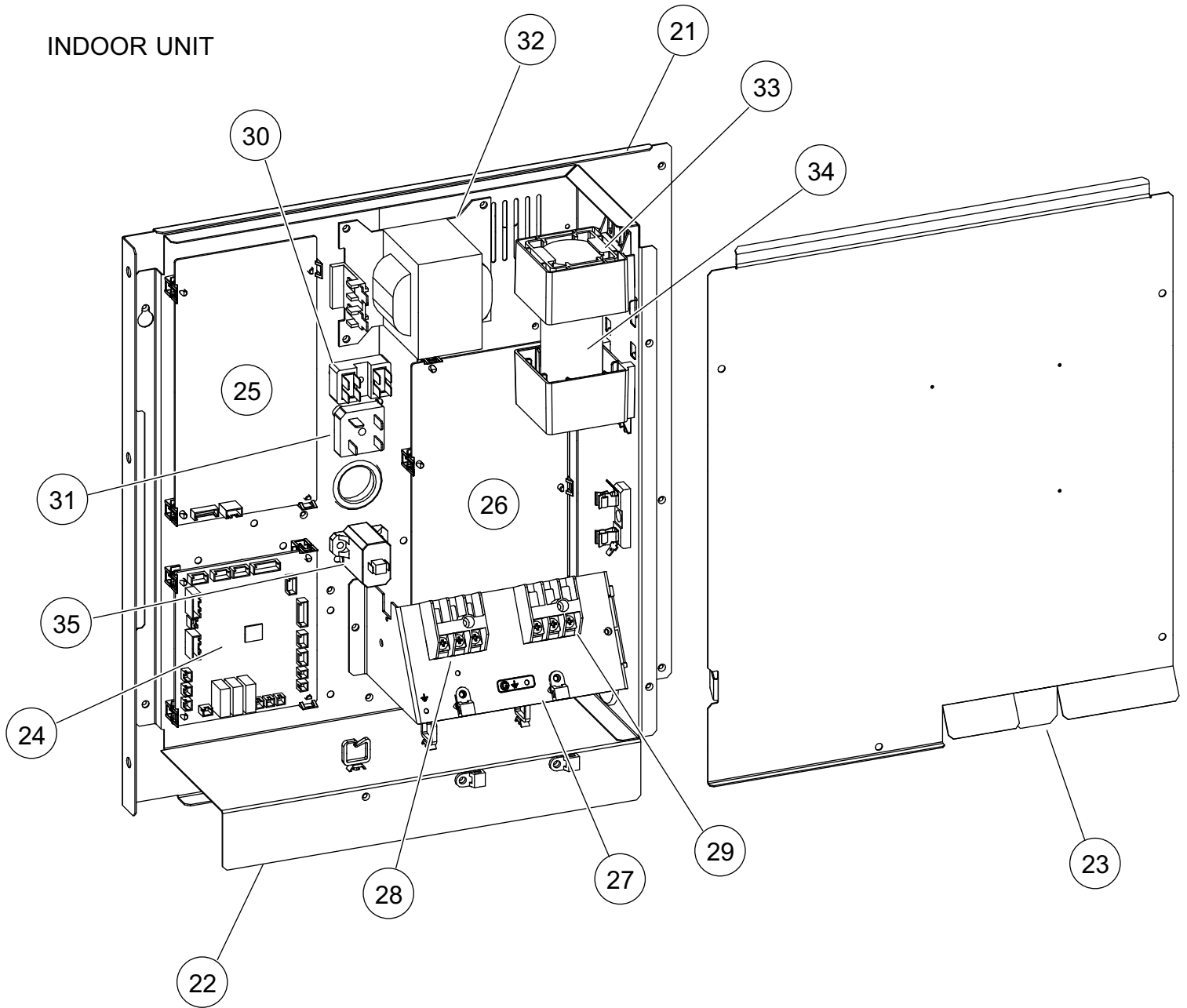

Ref.	Description	Parts number
21	Seal Plate Sub Assy	9380195009
22	Control Box Assy	9380254003
23	Control Box Cover Sub Assy	9380309024
24	Main PCB	9708281070
25	Power Supply PCB	9708279015
26	Filter PCB	9708277028
27	Terminal Bracket	9380251002
28	Terminal (Remote)	9900567002

Ref.	Description	Parts number
29	Terminal (Power)	9900568009
30	Terminal	9900433017
31	Diode (Power)	0000292917
32	Reactor Assy	9900460013
33	Capacitor Bracket	9373155010
34	Capacitor	9704594013
35	Thermistor	9704265012
--	Pipe Thermistor	9900558000
--	Room Thermistor	9703299254

PARTS

OUTDOOR UNIT

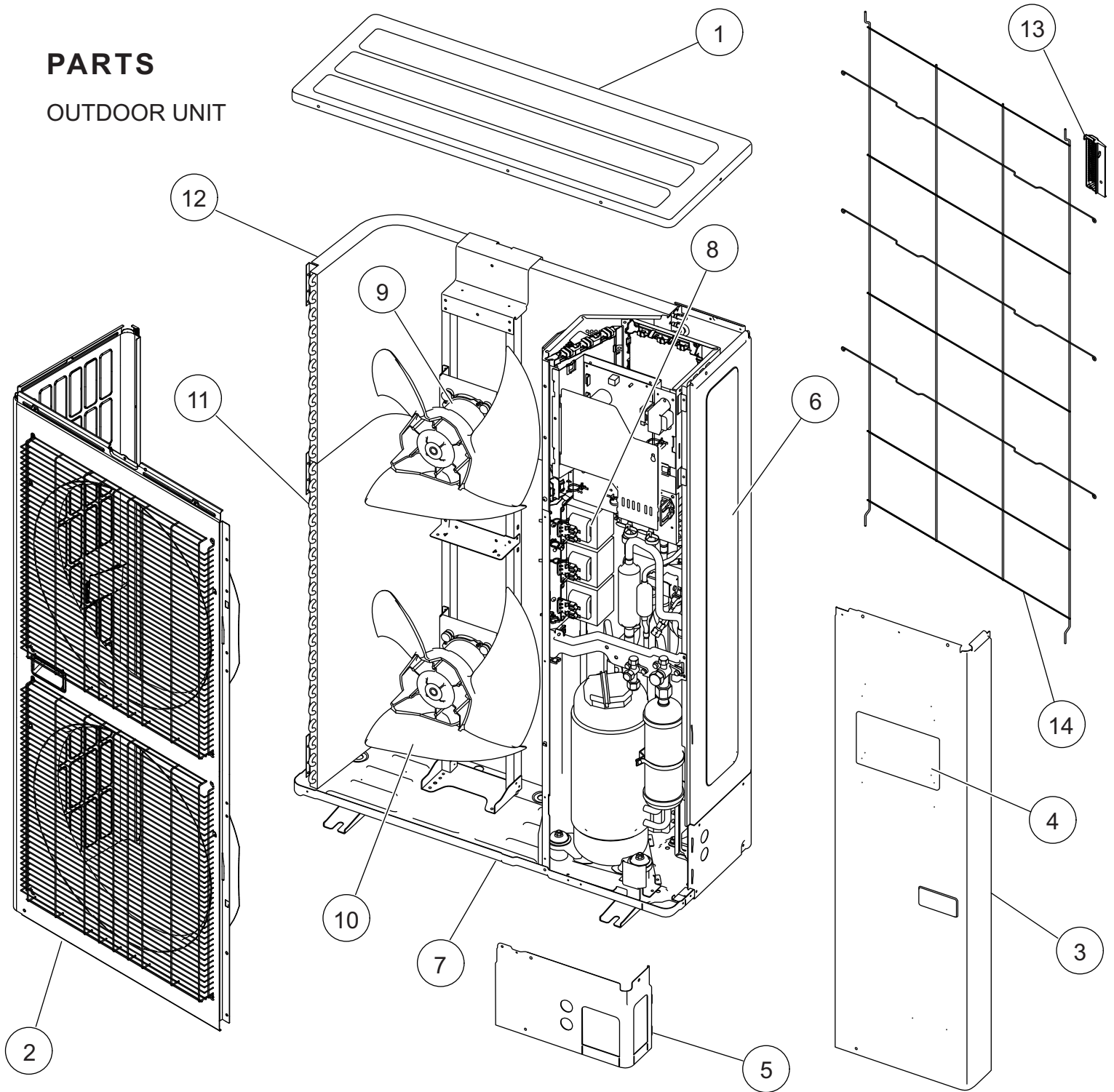

Ref.	Description	Parts number
1	Top Panel Sub Assy	9374417032
2	Front Panel Sub Assy	9374414130
3	Service Panel Sub Assy	9374415076
4	Emblem Rear	9351355005
5	Pipe Cover Front	9378861015
6	Right Panel Sub Assy	9374416219
7	Base Assy	9374166220

Ref.	Description	Parts number
8	Reactor Assy	9900641016
9	Motor, DC Brushless	9602843046
10	Propeller Fan Assy	9366378020
11	Condenser A Sub Assy	9374420261
12	Condenser B Sub Assy	9374422081
13	Thermo Holder	9375211011
14	Protective Net	9375381042

OUTDOOR UNIT

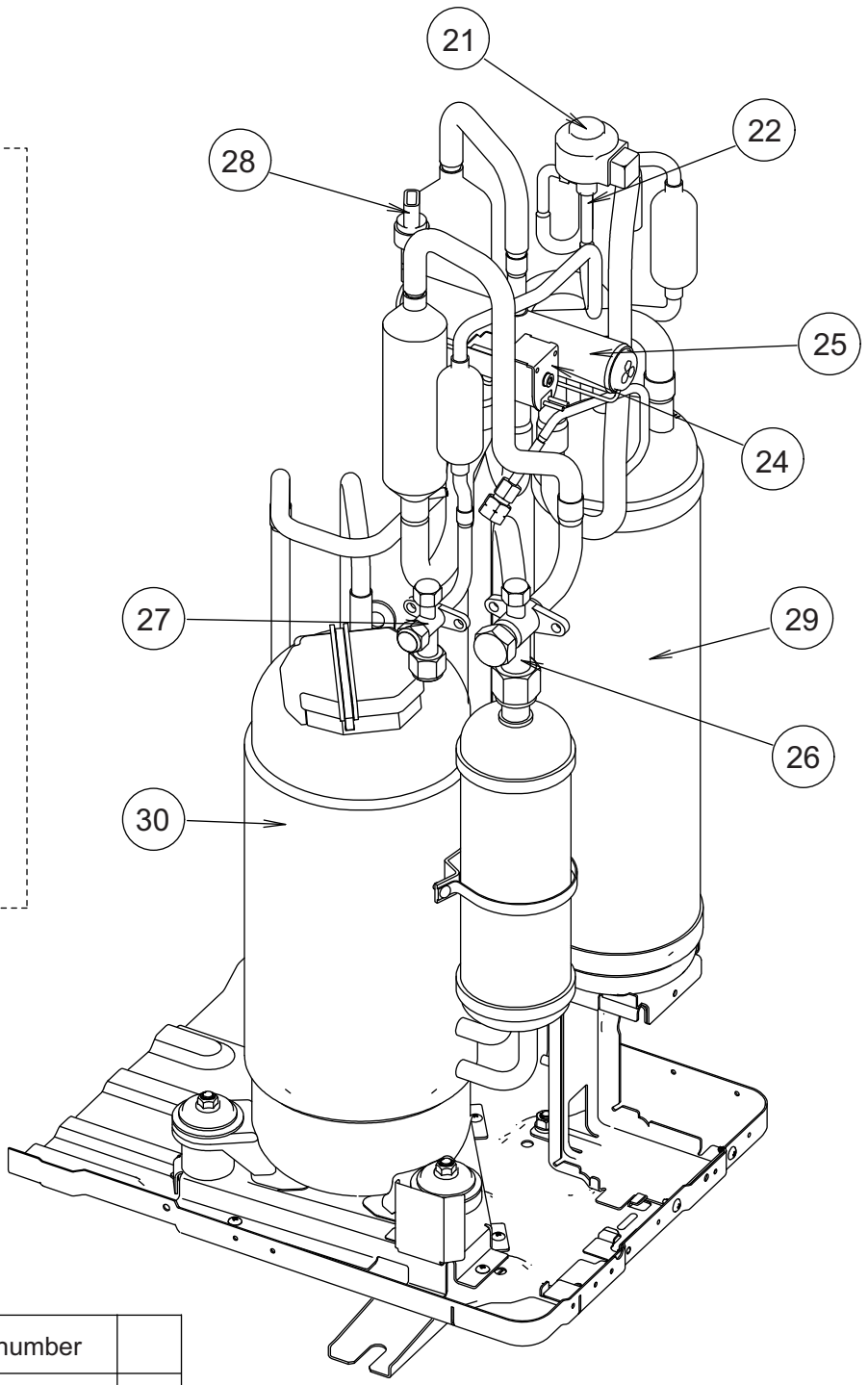
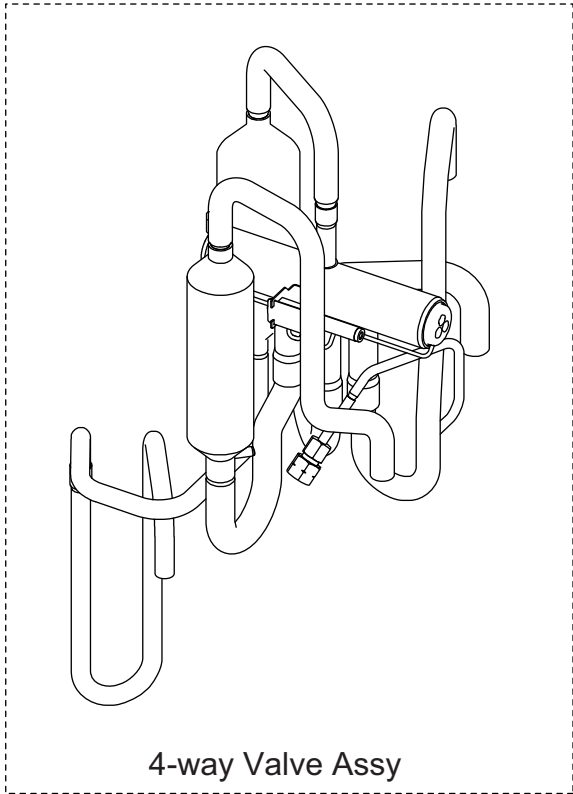

Ref.	Description	Parts number	
21	Expansion Valve Coil	9900190057	
22	Expansion Valve Assy	9370947182	
23	Strainer Assy	9372524039	
24	Solenoid	9970113024	
25	4-way Valve Assy	9374425273	
26	3-way Valve Assy	9379079006	
27	3-way Valve Assy	9379077002	
28	Sensor	9900505011	
29	Accumulator Assy	9375250096	
30	Compressor Sub Assy	9374423286	

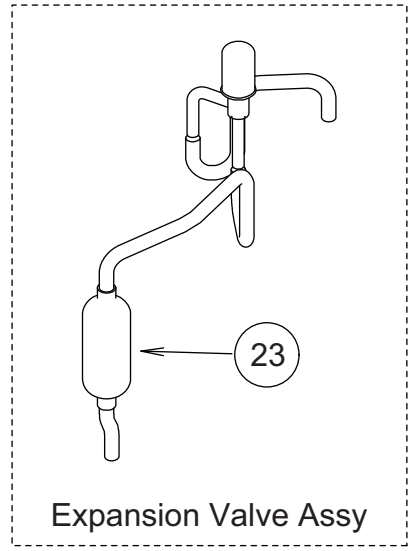

OUTDOOR UNIT

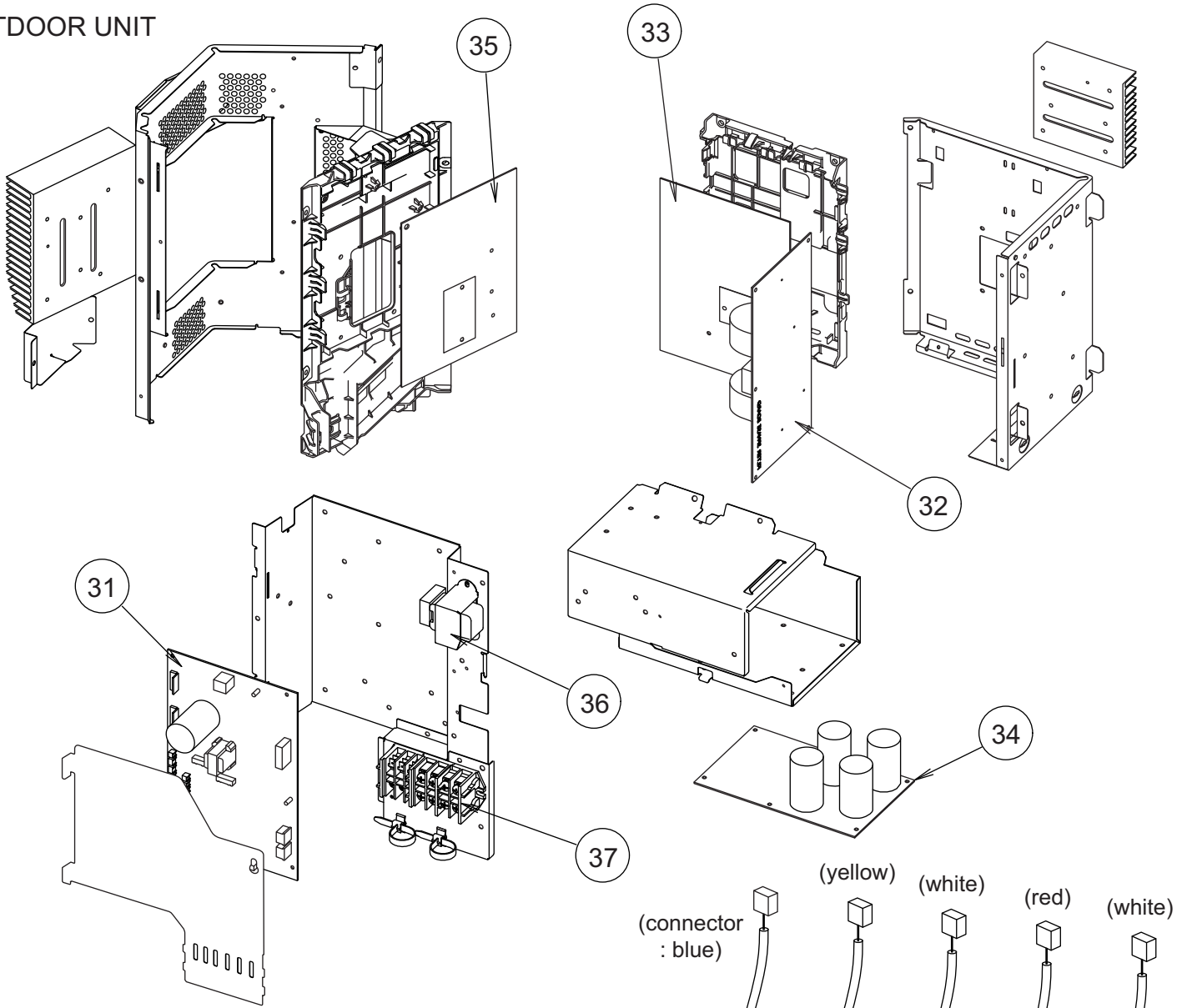

Ref.	Description	Parts number
31	Main PCB	9709249048
32	Filter PCB	9707609011
33	Active Filter PCB	9709008010
34	Capacitor PCB	9707608014
35	Transistor PCB	9709010020
36	Reactor Assy	9900481018
37	Terminal	9900428082
38	Compressor Thermistor	9900516000
39	Discharge Thermistor	9900515003
40	Thermistor (Heat Exchanger Mid)	9900513009
41	Thermistor (Heat Exchanger Out)	9900514006
42	Outdoor Thermistor	9900517007
43	Heatsink Thermistor (Inverter)	9900518011
44	Heatsink Thermistor (PFC)	9900518028

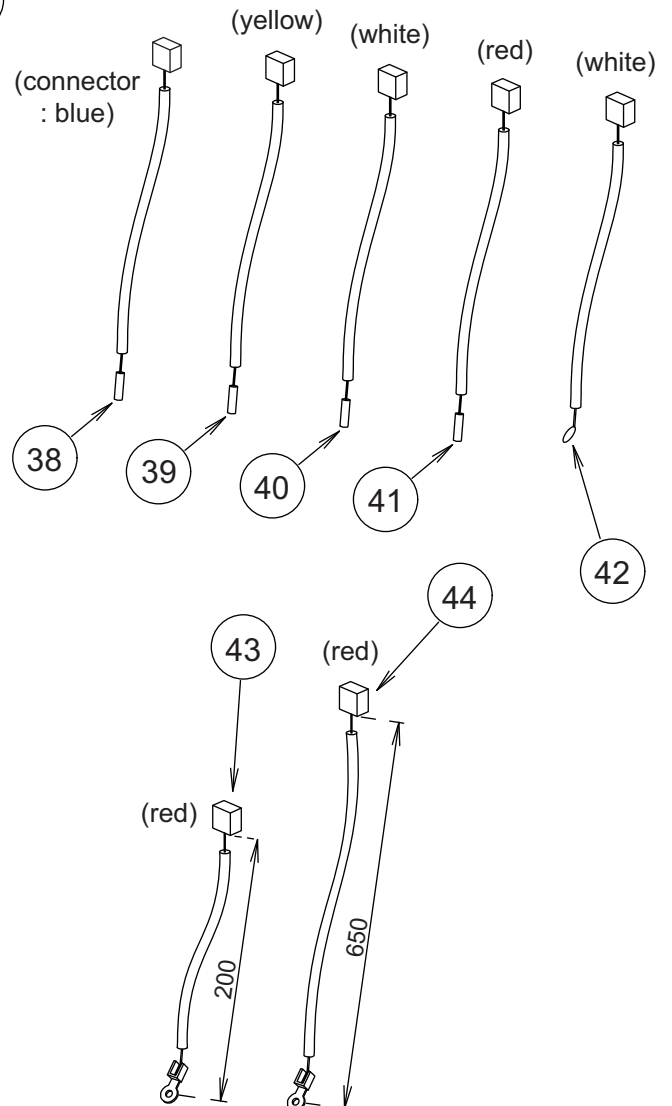

ACCESSORIES

INDOOR UNIT

Exterior	Q'ty	Use
Special nut A (Large flange)	4	313005446653 For suspending the indoor unit from ceiling
Special nut A (small flange)	4	313005446759
Coupler heat insulation (Large)	1	9378173569 For indoor side pipe joint (Gas pipe)
Coupler heat insulation (Small)	1	9378173521 For indoor side pipe joint (Liquid pipe)
Cable tie (Large)	4	312300787605 For fixing the heat insulation
Cable tie (Medium)	4	313035356905 For fixing the remote control cable and connection cable
Cable tie (Small)	1	313361275805 For fixing the remote control cable
Remote control	1	9318593020 For Air conditioner operation
Screw (Flush heads)	2	0700181108 For installing indoor unit remote control

OPTIONAL PARTS

Exterior	Model	Use
Wired remote control	UTY-RNNYN	For Air conditioner operation
Simple remote control	UTY-RSNNY	For Air conditioner operation
Remote sensor	UTY-XSZX	New amenity space can be offered by installing the Remote sensor in the remote control
I.R receiver unit	UTY-LRHYM	For Air conditioner operation and demand response display
External control set	UTD-ECS5A	Use to connect various peripheral devices and air conditioner PC board

OUTDOOR UNIT

Exterior	Q'ty	Use
Drain pipe	1	9303029015 For outdoor unit drain piping work (May not be supplied, depending on the model.)
Drain cap	2	313166024302
One-touch bush	2	9378779013 For power supply cable and connection cable installation

1302G4182