

AIR CONDITIONER

Simultaneous multi

SERVICE MANUAL

INDOOR



AUXG18KVLA × 2
AUXG22KVLA × 2
AUXG24KVLA × 2
AUXG18KVLA × 3



ARXG18KLLAP × 2
ARXG18KLLAP × 3



ARXG22KMLA × 2
ARXG24KMLA × 2

OUTDOOR



AOYG36KRTA



AOYG45KRTA
AOYG54KRTA

Notices:

- Product specifications and design are subject to change without notice for future improvement.
- For further details, please check with our authorized dealer.

Trademarks

FGLair™ is trademark of Fujitsu General Limited in the United States, other countries or both.

Google Play™ is trademark of Google Inc.

App Store® is a service mark of Apple Inc., registered in the U.S. and other countries.

CONTENTS

1. GENERAL INFORMATION

2. TECHNICAL DATA AND PARTS LIST

3. TROUBLESHOOTING

4. CONTROL AND FUNCTIONS

5. FIELD WORKING



1. GENERAL INFORMATION



CONTENTS





1. GENERAL INFORMATION

1. Model lineup	01-1
2. Specifications	01-2
2-1. Compact cassette type	01-2
2-2. Slim duct type	01-3
2-3. Medium static pressure duct type	01-4
2-4. Outdoor unit	01-5
3. Dimensions	01-8
3-1. Compact cassette type	01-8
3-2. Slim duct type	01-10
3-3. Duct type	01-12
3-4. Outdoor unit	01-14

1. Model lineup

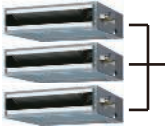
Indoor unit		Outdoor unit
Twin		
18 kBtu/h × 2		
 ARXG18KLLAP		 AOYG36KRTA
 AUXG18KVLA		

Indoor unit		Outdoor unit
Twin		
22 kBtu/h × 2		
 ARXG22KMLA		 AOYG45KRTA
 AUXG22KVLA		

Indoor unit		Outdoor unit
Twin	Triple	
24 kBtu/h × 2	18 kBtu/h × 3	
 ARXG24KMLA	 ARXG18KLLAP	 AOYG54KRTA
 AUXG24KVLA	 AUXG18KVLA	

2. Specifications

2-1. Compact cassette type

Model name				AUXG18KVLA	AUXG22KVLA	AUXG24KVLA
Power supply				3N 400 V ~50 Hz		
Power supply intake				Outdoor unit		
Available voltage range				342—457 V		
Fan	Airflow rate	Cooling	HIGH	680	830	930
			MED	580	740	830
			LOW	490	600	600
			QUIET	410		450
		Heating	HIGH	800	860	930
			MED	680	760	860
			LOW	580		700
			QUIET	450		530
	Type × Q'ty		Turbo fan × 1			
	Motor output		W			
		54				
Sound pressure level*1	Cooling	HIGH	38	44	49	
		MED	34	42	44	
		LOW	30	36	36	
		QUIET	26	30	30	
	Heating	HIGH	43	45	49	
		MED	38	43	45	
		LOW	34		40	
		QUIET	30		33	
Heat exchanger type	Dimensions (H × W × D)		mm	210 × 1,310 × 13.3 210 × 1,250 × 13.3		210 × 1,360 × 13.3 210 × 1,295 × 13.3 210 × 1,235 × 13.3
	Fin pitch		mm	1.20		1.45
	Rows × Stages			2 × 10		3 × 10
	Pipe type			Copper tube		
	Fin type			Aluminum		
Dimensions (H × W × D)	Net		mm	245 × 570 × 570		
	Gross			265 × 730 × 625		
Weight	Net		kg	15		16
	Gross			19		20
Connection pipe	Size	Liquid	mm (in)	Ø 6.35 (1/4)		
		Gas		Ø 12.70 (1/2)		
	Method			Flare		
Operation range	Cooling		°C	18 to 32		
			%RH	80 or less		
	Heating		°C	16 to 30		
Drain hose	Material			PVC		
	Size		mm	Ø 25 (I.D.), Ø 32 (O.D.)		
Cassette grille (Option)	Model name			UTG-UFYF-W		
	Material			PS		
	Color			White Approximate color of Munsell 9PB 9.1/0.2		
	Dimensions (H × W × D)	Net		mm	49 × 620 × 620	
		Gross			120 × 765 × 755	
	Weight	Net		kg	2.3	
Gross			4.5			
Remote controller type (option)				Wired remote controller, Wireless remote controller, Mobile app*2 (FGLair™)		
NOTES:						
<ul style="list-style-type: none"> The protective function might work when using it outside the operation range. *1: Sound pressure level: <ul style="list-style-type: none"> These are the measured values in the manufacturer's anechoic chamber. Because of the surrounding sound environment, the sound levels measured in actual installation conditions might be higher than the specified values here. *2: Available on Google Play™ store or on App Store®. Optional WLAN adapter is also required. For details, refer to the setting manual. 						

2-2. Slim duct type

Model name				ARXG18KLLAP
Power supply				3N 400 V ~50 Hz
Power supply intake				Outdoor unit
Available voltage range				342–457 V
Fan	Airflow rate	Cooling	HIGH	940
			MED	880
			LOW	820
			QUIET	750
		Heating	HIGH	940
			MED	880
			LOW	820
			QUIET	750
	Type × Q'ty			Sirocco fan × 3
	Motor output			W 96
Recommended static pressure			Pa 0 to 90	
Sound pressure level*1	Cooling	HIGH	32	
		MED	30	
		LOW	29	
		QUIET	27	
	Heating	HIGH	32	
		MED	30	
		LOW	29	
		QUIET	27	
Heat exchanger type	Dimensions (H × W × D)		mm 294 × 700 × 39.9	
	Fin pitch		mm 1.30	
	Rows × Stages		3 × 14	
	Pipe type		Copper tube	
	Fin type		Aluminum	
Enclosure	Material			Steel sheet
	Color			—
Dimensions (H × W × D)	Net		mm 198 × 900 × 620	
	Gross		mm 276 × 1,168 × 772	
Weight	Net		kg 20	
	Gross		kg 26	
Connection pipe	Size	Liquid	mm (in) Ø 6.35 (1/4)	
		Gas	Ø 12.70 (1/2)	
	Method		Flare	
Operation range	Cooling	°C	18 to 32	
		%RH	80 or less	
	Heating	°C	16 to 30	
Drain hose	Material			PVC
	Size		mm Ø 25 (I.D.), Ø 32 (O.D.)	
Remote controller type (option)				Wired remote controller, Wireless remote controller, Mobile app*2 (FGLair™)
NOTES:				
<ul style="list-style-type: none"> • Values mentioned in the table are based on the following conditions: <ul style="list-style-type: none"> – Static pressure: 25 Pa • The protective function might work when using it outside the operation range. • *1: Sound pressure level: <ul style="list-style-type: none"> – These are the measured values in the manufacturer's anechoic chamber. – Because of the surrounding sound environment, the sound levels measured in actual installation conditions might be higher than the specified values here. • *2: Available on Google Play™ store or on App Store®. Optional WLAN adapter is also required. For details, refer to the setting manual. 				

2-3. Medium static pressure duct type

Model name				ARXG22KMLA	ARXG24KMLA	
Power supply				3N 400 V ~50 Hz		
Power supply intake				Outdoor unit		
Available voltage range				342—457 V		
Fan	Airflow rate	Cooling	HIGH	m ³ /h	1,100	
			MED		910	
			LOW		750	
			QUIET		580	
		Heating	HIGH		1,100	
			MED		910	
			LOW		750	
			QUIET		580	
	Type × Q'ty				Sirocco fan × 2	
	Motor output				W 106	
Recommended static pressure				Pa 30 to 150		
Sound pressure level*1	Cooling	HIGH	dB (A)	31		
		MED		29		
		LOW		27		
		QUIET		25		
	Heating	HIGH		31		
		MED		29		
		LOW		27		
		QUIET		25		
Heat exchanger type	Dimensions (H × W × D)		mm	294 × 1,000 × 39.9		
	Fin pitch		mm	1.40		
	Rows × Stages			3 × 14		
	Pipe type			Copper		
	Fin type			Aluminum		
Enclosure	Material			Steel sheet		
	Color			—		
Dimensions (H × W × D)	Net		mm	270 × 1,135 × 700		
	Gross			300 × 1,320 × 790		
Weight	Net		kg	35		
	Gross			43		
Connection pipe	Size	Liquid	mm (in)	Ø 6.35 (1/4)		
		Gas		Ø 12.70 (1/2)		
	Method			Flare		
Operation range	Cooling		°C	18 to 32		
			%RH	80 or less		
	Heating		°C	16 to 30		
Drain port	Material			Steel		
	Size		mm	Ø 35.7 (I.D.), Ø 38.1 (O.D.)		
Remote controller type (option)				Wired remote controller, Wireless remote controller, Mobile app*2 (FGLair™)		
<p>NOTES:</p> <ul style="list-style-type: none"> • Values mentioned in the table are based on the following conditions: <ul style="list-style-type: none"> – Static pressure: 35 Pa • The protective function might work when using it outside the operation range. • *1: Sound pressure level: <ul style="list-style-type: none"> – These are the measured values in the manufacturer's anechoic chamber. – Because of the surrounding sound environment, the sound levels measured in actual installation conditions might be higher than the specified values here. • *2: Available on Google Play™ store or on App Store®. Optional WLAN adapter is also required. For details, refer to the setting manual. 						

2-4. Outdoor unit

Type				Inverter heat pump			
Model name				AOYG36KRTA	AOYG45KRTA	AOYG54KRTA	
Power supply				3N 400 V ~ 50 Hz			
Power supply intake				Outdoor unit			
Available voltage range				342—457 V			
Indoor unit combination				AUXG18KVLA × 2 ARXG18KLLAP × 2	AUXG22KVLA × 2 ARXG22KMLA × 2	AUXG24KVLA × 2 ARXG24KMLA × 2 AUXG18KVLA × 3 ARXG18KLLAP × 3	
Capacity	Cooling	Rated	kW	9.5	12.1	13.4	
			Btu/h	32,400	41,300	45,700	
		Min.—Max.	kW	2.8—11.2	4.0—13.0	4.5—14.5	
	Heating	Rated	Btu/h	9,500—38,200	13,700—44,300	15,300—49,400	
			kW	10.8	13.5	15.5	
		Min.—Max.	Btu/h	36,800	46,000	52,900	
Input power	Cooling	Rated	kW	2.97	4.22	4.42	
			Max.	4.29	5.03	5.39	
		Heating	Rated	2.88	3.84	4.16	
	Heating	Rated	kW	4.66	4.79	4.88	
			Max.	5.7	7.7	8.0	
		Current	Cooling	Max.	10.5	14.0	14.0
Heating	Rated	A	5.6	7.1	7.6		
		Max.	10.5	14.0	14.0		
	EER	Cooling		3.20	2.87	3.03	
COP	Heating		3.75	3.52	3.73		
Power factor	Cooling		75.4	79.6	80.4		
	Heating		75.1	78.2	79.4		
Starting current			A	5.7	7.7	8.0	
Maximum operating current*1			A	10.5	14.0	14.0	
Fan	Airflow rate	Cooling	m ³ /h	3,750	4,450	4,450	
		Heating		3,750	4,450	4,450	
	Type × Q'ty				Propeller × 1		
	Motor output		W	100	120	120	
Sound pressure level*2	Cooling	dB (A)		55	57	59	
			Heating	55	71	73	
Sound power level	Cooling	dB (A)		70	71	73	
			Heating	70	71	73	
Heat exchanger type	Dimensions (H × W × D)	mm		Main1: 756 × 905 × 18.19 Main2: 756 × 905 × 18.19	Main1: 966 × 905 × 18.19 Main2: 966 × 905 × 18.19 Sub: 966 × 543 × 18.19		
			Fin pitch		Main1: 1.45 Main2: 1.45	Main1: 1.45 Main2: 1.45 Sub: 1.45	
	Rows × Stages			Main1: 1 × 36 Main2: 1 × 36	Main1: 1 × 46 Main2: 1 × 46 Sub: 1 × 46		
	Pipe type			Copper			
	Fin	Type (Material)		Aluminum			
		Surface treatment		Blue fin			
Compressor	Type × Q'ty			DC Twin rotary × 1			
	Motor output		W	1,500	2,180	2,180	
Refrigerant	Type (Global warming potential)			R32 (675)			
	Factory charge		g	1,900	2,700	2,700	
Refrigerant oil	Type			FW68D	RmM68AF		
	Amount		cm ³	600	800	800	
Enclosure	Material			Steel sheet			
	Color			Beige			
Dimensions (H × W × D)	Net		mm	788 × 940 × 320	998 × 940 × 320		
	Gross			966 × 1,027 × 445	1,176 × 1,027 × 445		
Weight	Net		kg	53	67		
	Gross			62	77		
Connection pipe	Size	Liquid	mm (in)	Ø9.52 (3/8)			
		Gas		Ø15.88 (5/8)			
	Method			Flare			
	Pre-charge length	Total			30		
		Max. length (Total)			50		
	Max. length (From the 1st separation tube)	To the farthest indoor unit		m	20		
		To the farthest indoor unit—To the nearest indoor unit			8		
	Max. height difference between outdoor unit and each indoor units				30		
Max. height difference between indoor units				0.5			
Operation range	Cooling		°C	-15 to 46			
	Heating			-15 to 24			
Drain hose	Material			LDPE			
	Size		mm	Ø13.0 (I. D.), Ø16.0 to Ø16.8 (O. D.)			

Type	Inverter heat pump		
Model name	AOYG36KRTA	AOYG45KRTA	AOYG54KRTA
NOTES: <ul style="list-style-type: none"> • Specifications are based on the following conditions: <ul style="list-style-type: none"> – Cooling: Indoor temperature of 27 °CDB/19 °CWB, and outdoor temperature of 35 °CDB/24 °CWB. – Heating: Indoor temperature of 20 °CDB/15 °CWB, and outdoor temperature of 7 °CDB/6 °CWB. – Pipe length: 5.0 m, Height difference: 0 m. (Between outdoor unit and indoor unit.) • Protective function might work when using it outside the operation range. • *1: Maximum operating current is the total current of the indoor unit and the outdoor unit. • *2: Sound pressure level <ul style="list-style-type: none"> – Measured values in manufacturer's anechoic chamber. – Because of the surrounding sound environment, the sound levels measured in actual installation conditions might be higher than the specified values here. 			

Specifications for ErP Lot10			
Model name		AOYG36KRTA	
Energy efficiency class	Cooling		A++
	Heating (Average)		A+
Pdesign	Cooling	kW	9.5 (35°C)
	Heating (Average)		8.7 (-10°C)
SEER	Cooling	kWh/kWh	6.1
SCOP	Heating (Average)		4.0
Annual energy consumption	QCE	kWh/a	545
	QHE (Average)		3,044
Sound power level	Cooling	HIGH	dB (A)
	Heating		

3. Dimensions

3-1. Compact cassette type

■ Models: AUXG18KVLA, AUXG22KVLA, and AUXG24KVLA

Unit: mm

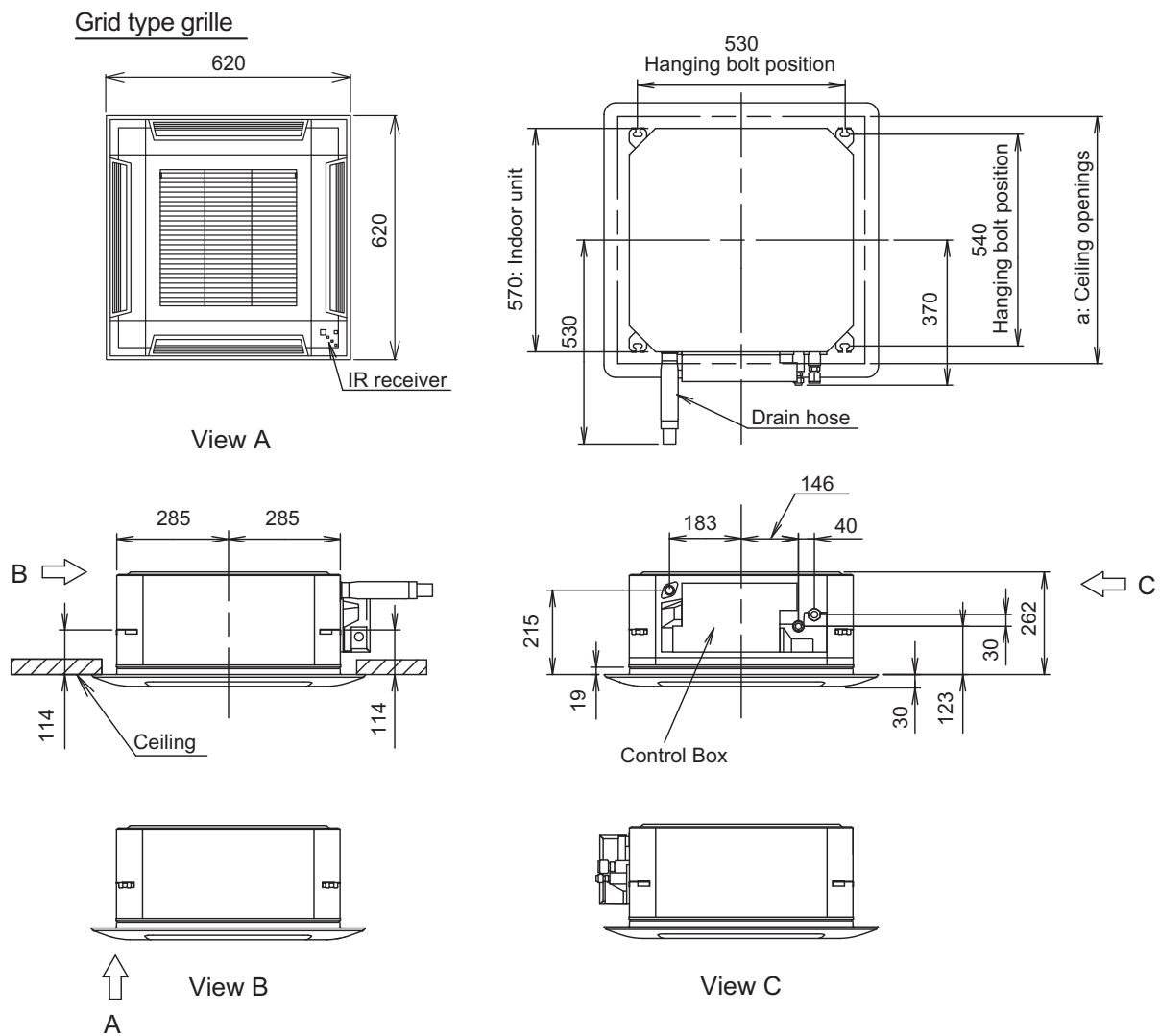

a: Ceiling openings		
Cassette grille (Option [Grid type])	mm	580 to 610

■ Installation space requirement

Unit: mm

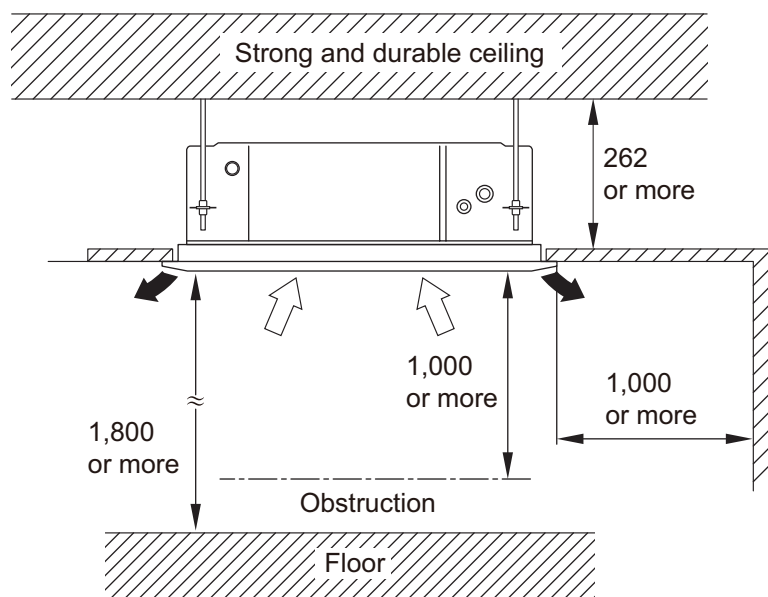

Maximum height from floor to ceiling (Unit: mm)	
Standard	2,700
High ceiling	3,000

3-way direction setting:

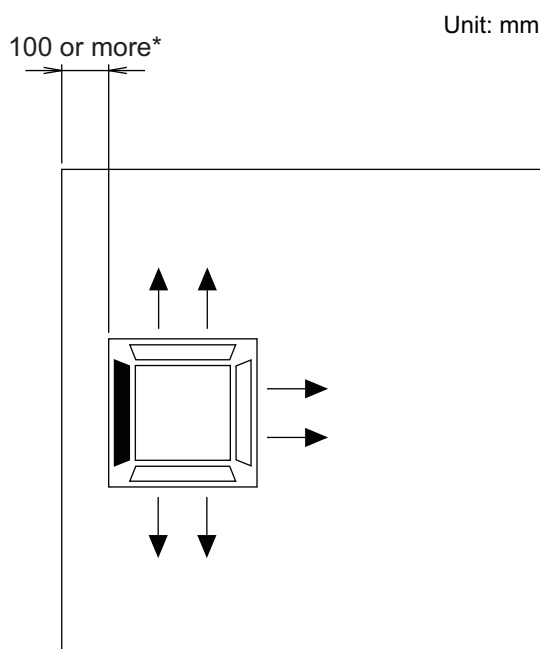

NOTES:

- To set "3-direction", optional Air outlet shutter plate (UTR-YDZB) must be installed, and the "outlet-direction" need to be switched to "3-way" by remote controller.
*When installing the indoor unit, be careful about the maintenance space.
- In 3-way outlet mode, changing of ceiling height setting by function setting 20 is prohibited.
(Ceiling height setting [function setting 20] is allowed to be changed only in 4-way outlet mode.)

3-2. Slim duct type

■ Model: ARXG18KLLAP

Unit: mm

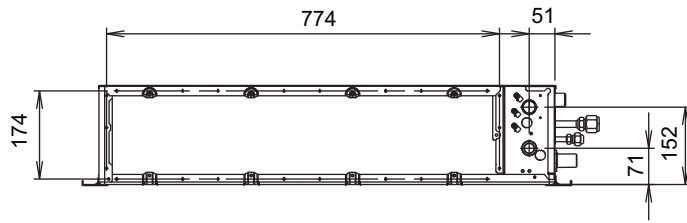

Rear view

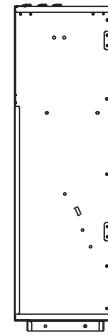

View A

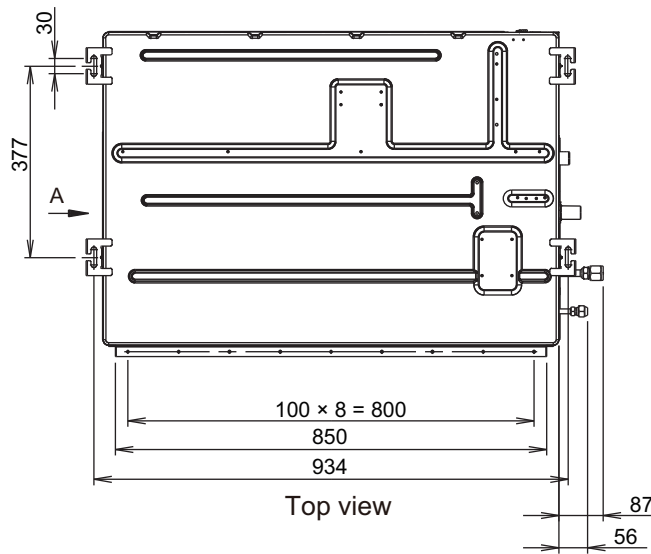

Top view

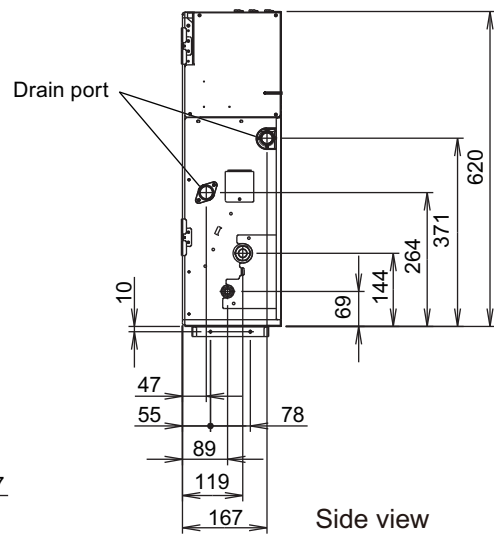

Side view

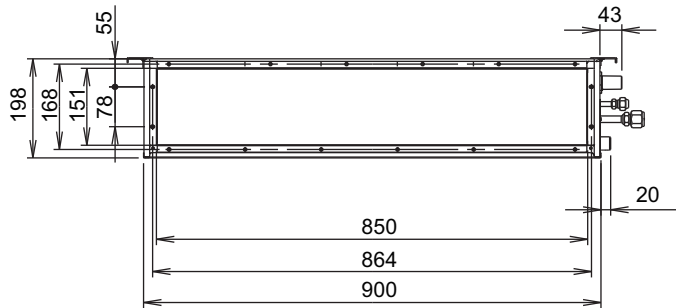

Front view

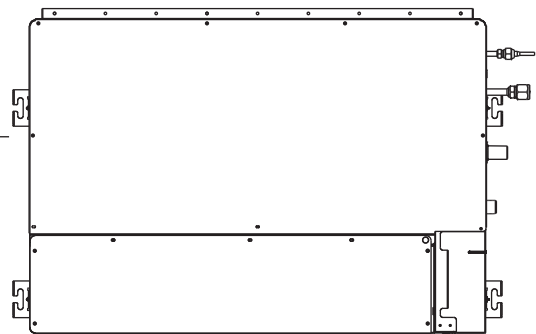

Bottom view

■ Installation space requirement

Provide sufficient installation space for product safety.

In ceiling-concealed installations:

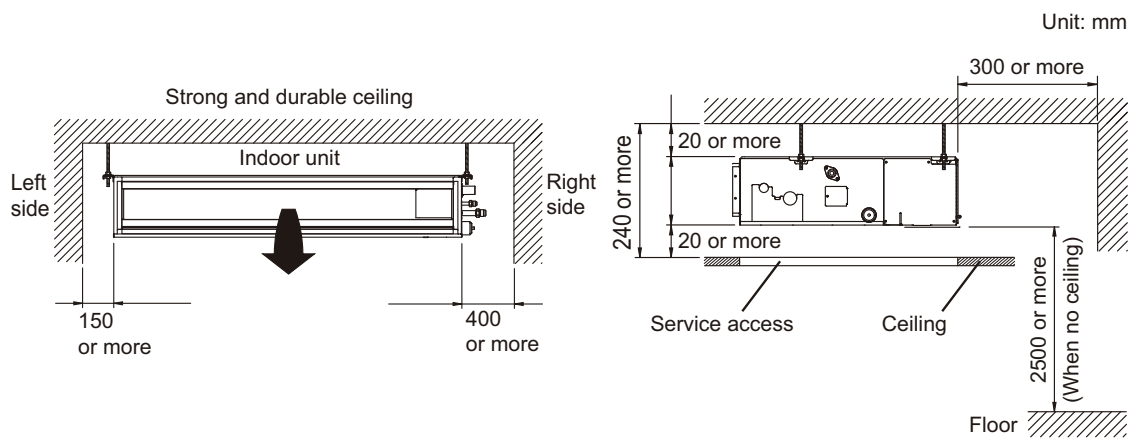

- Bottom air intake hole

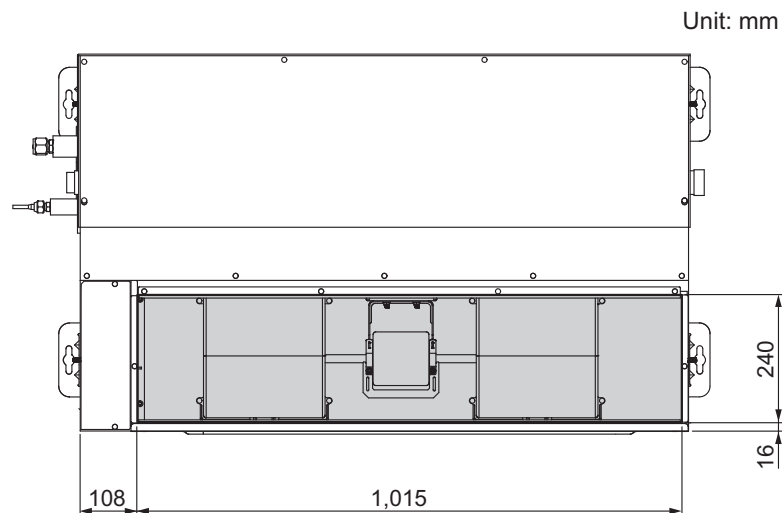

■ Installation space requirement

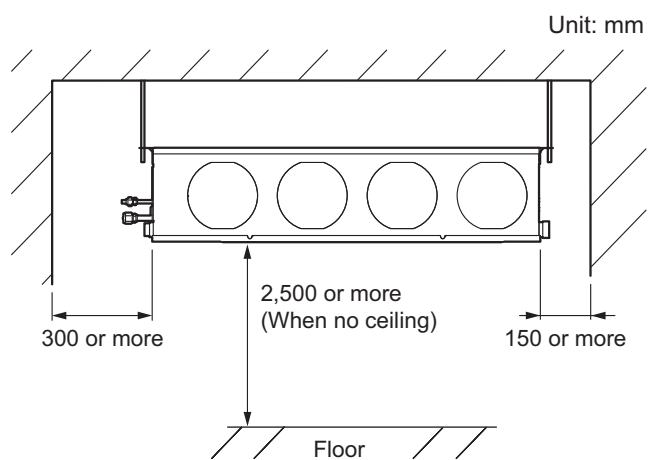

3-4. Outdoor unit

Model: AOYG36KRTA

Unit: mm

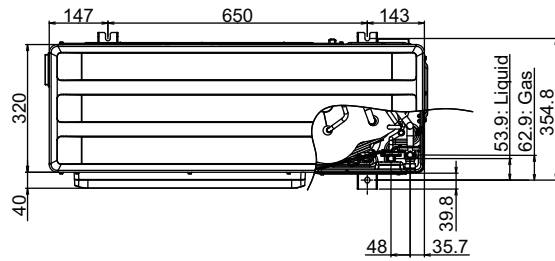

Top view

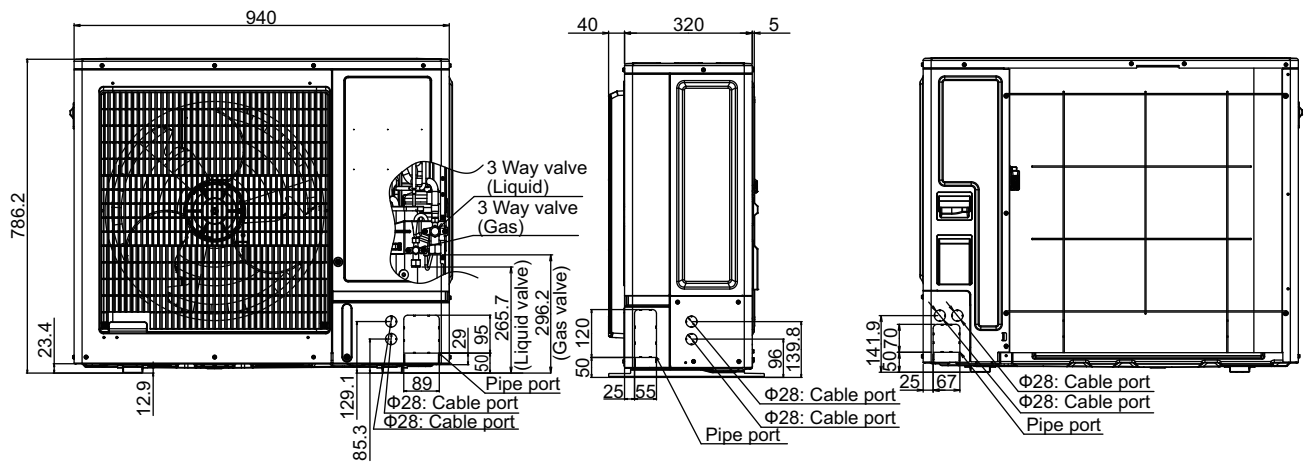

Front view

Side view

Rear view

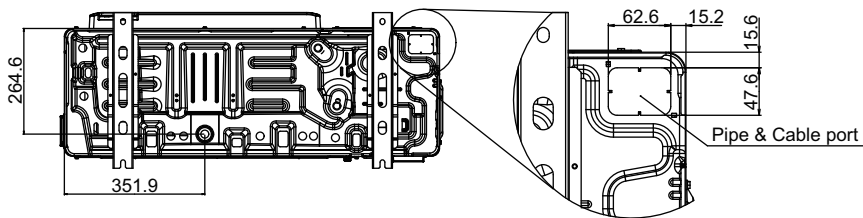

Bottom view

Models: AOYG45KRTA and AOYG54KRTA

Unit: mm

GENERAL INFORMATION

GENERAL INFORMATION

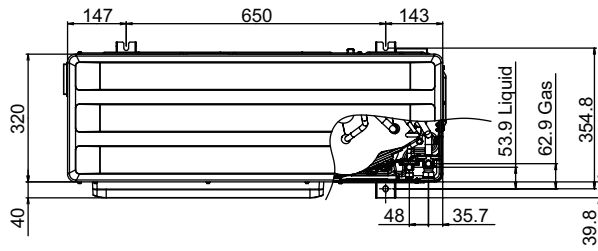

Top view

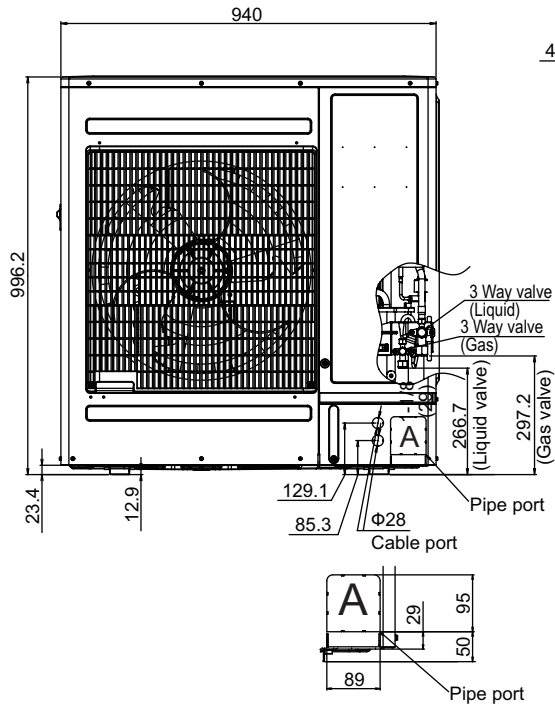

Front view

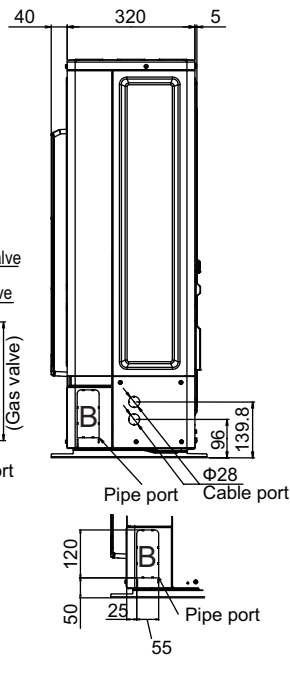

Side view

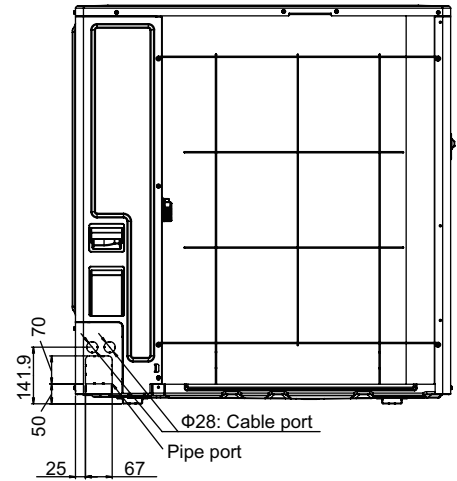

Rear view

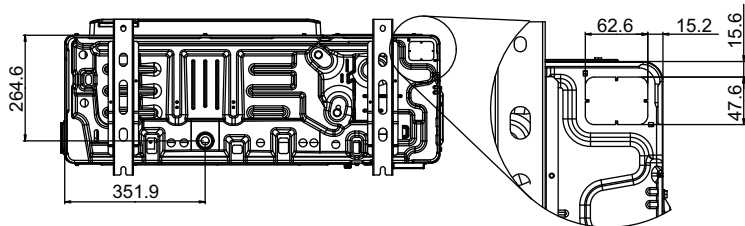

Bottom view

Pipe & Cable port

2. TECHNICAL DATA AND PARTS LIST

CONTENTS

2. TECHNICAL DATA AND PARTS LIST

1. Precautions	02-1
2. Cassette grille (optional part) parts list	02-2
2-1. Model: UTG-UFYF-W	02-2
3. Indoor unit parts list	02-6
3-1. Models: AUXG18KVLA, AUXG22KVLA, and AUXG24KVLA	02-6
3-2. Model: ARXG18KLLAP	02-11
3-3. Models: ARXG22KMLA and ARXG24KMLA	02-14
4. Outdoor unit parts list	02-18
4-1. Model: AOYG36KRTA.....	02-18
4-2. Models: AOYG45KRTA and AOYG54KRTA	02-22
5. Accessories	02-26
5-1. Indoor unit	02-26
5-2. Outdoor unit.....	02-28
6. Optional parts	02-29
6-1. Branch pipes.....	02-29
6-2. Controllers	02-31
6-3. Cassette grille.....	02-32
6-4. Others.....	02-33
7. Refrigerant system diagrams	02-36
7-1. Models: AOYG36KRTA, AOYG45KRTA, and AOYG54KRTA	02-36
8. Wiring diagrams	02-37
8-1. Indoor unit	02-37
8-2. Outdoor unit.....	02-38
9. PC board diagrams	02-40
9-1. Models: AUXG18KVLA, AUXG22KVLA, and AUXG24KVLA	02-40
9-2. Model: ARXG18KLLAP	02-41
9-3. Models: ARXG22KMLA and ARXG24KMLA	02-42
9-4. Models: AOYG36KRTA, AOYG45KRTA, and AOYG54KRTA	02-43

1. Precautions

When you start servicing, pay attention to the following points. For detailed precautions, refer to the installation manual of the products.

⚠ CAUTION

-
- Service personnel
 - Any person who is involved with working on or breaking into a refrigerant circuit should hold a current valid certificate from an industry-accredited assessment authority, which authorizes their competence to handle refrigerants safely in accordance with an industry recognized assessment specification.
 - Servicing shall only be performed as recommended by the equipment manufacturer. Maintenance and repair requiring the assistance of other skilled personnel shall be carried out under the supervision of the person competent in the use of flammable refrigerants.
 - Servicing shall be performed only as recommended by the manufacturer.
 - Work
 - Prior to beginning work on systems containing flammable refrigerants, safety checks are necessary to ensure that the risk of ignition is minimized. When repairing the refrigerant system, refer to the precautions written in the installation manual of the products before you start servicing.
 - Work shall be undertaken under a controlled procedure so as to minimize the risk of a flammable gas or vapor being present while the work is being performed.
 - All maintenance staff and others working in the local area shall be instructed on the nature of work being carried out.
 - Work in confined spaces shall be avoided.
 - The area around the workspace shall be sectioned off.
 - Ensure that the conditions within the area have been made safe by control of flammable material.
 - Electric shock may occur. After turning off the power, always wait 5 minutes before touching electrical components.
 - Do not touch the fins of the heat exchanger. Touching the heat exchanger fins could result in damage to the fins or personal injury such as skin rupture.
 - Do not place any other electrical products or household belongings under the product.
 - Condensation dripping from the product might get them wet, and may cause damage or malfunction to the property.
 - Checking for presence of refrigerant
 - The area shall be checked with an appropriate refrigerant detector prior to and during work, to ensure the technician is aware of potentially flammable atmospheres.
 - Ensure that the leak detection equipment being used is suitable for use with flammable refrigerants, i.e. non-sparking, adequately sealed or intrinsically safe.
-
- Service parts information and design are subject to change without notice for product improvement.
 - For the latest information of the service parts, refer to our Service Portal.
<https://fujitsu-general.force.com/portal/>
 - Precise figure of the service parts listed in this manual may differ from the actual service parts.

2. Cassette grille (optional part) parts list

2-1. Model: UTG-UFYF-W

■ Panels

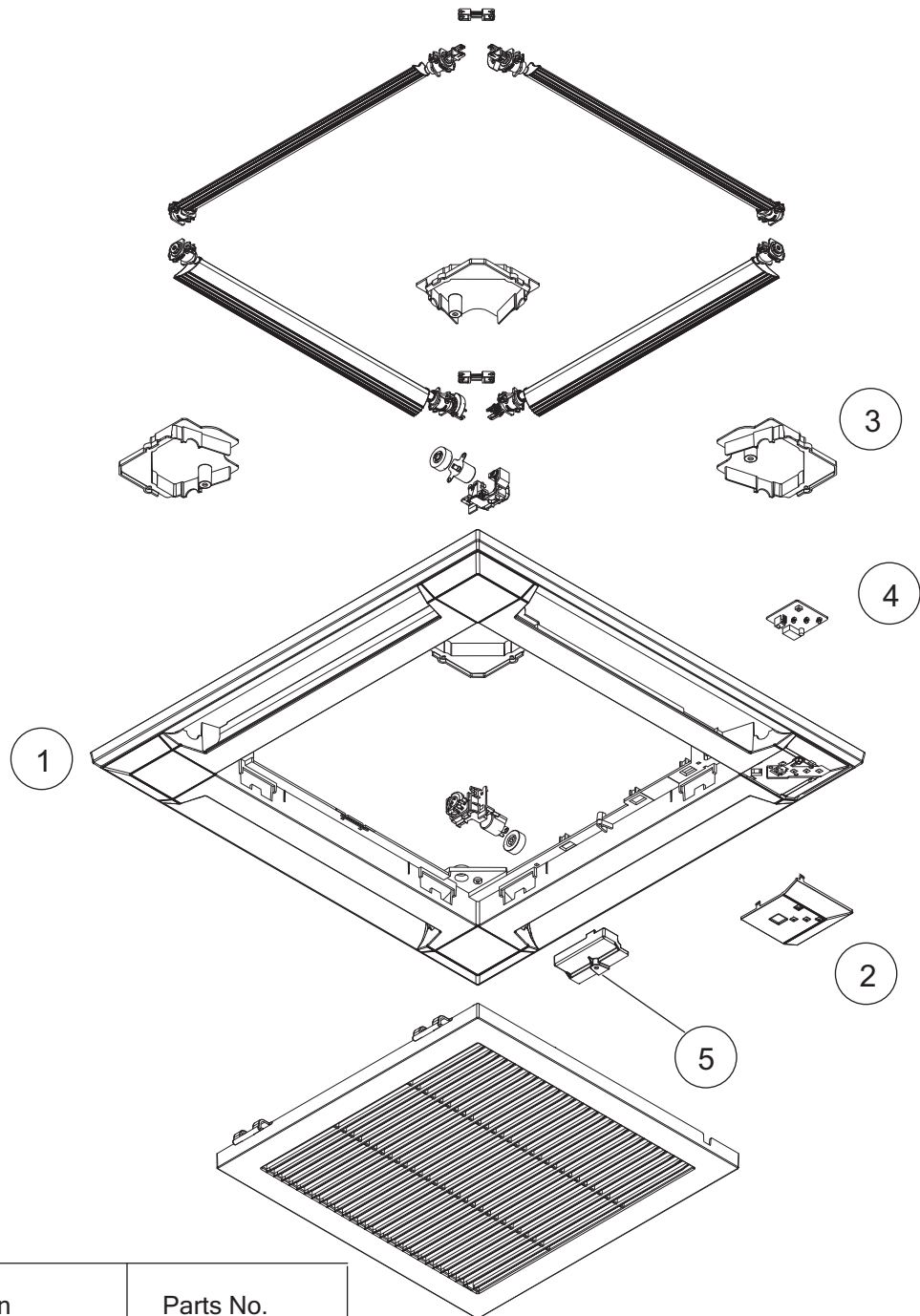

Ref	Description	Parts No.
1	Decoration Panel without Insulations	9382821005
2	Display panel assy	9383100031
3	Panel Cover without Insulations	9375530013
4	Indicator PCB	9711310002
5	Connector Cover	9375549015

Intake grille

TECHNICAL DATA
AND PARTS LIST

TECHNICAL DATA
AND PARTS LIST

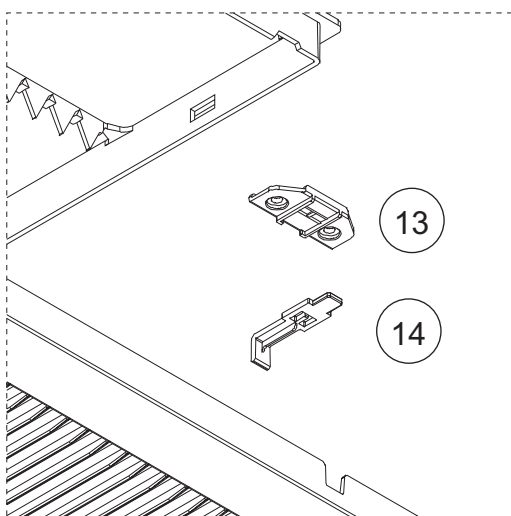
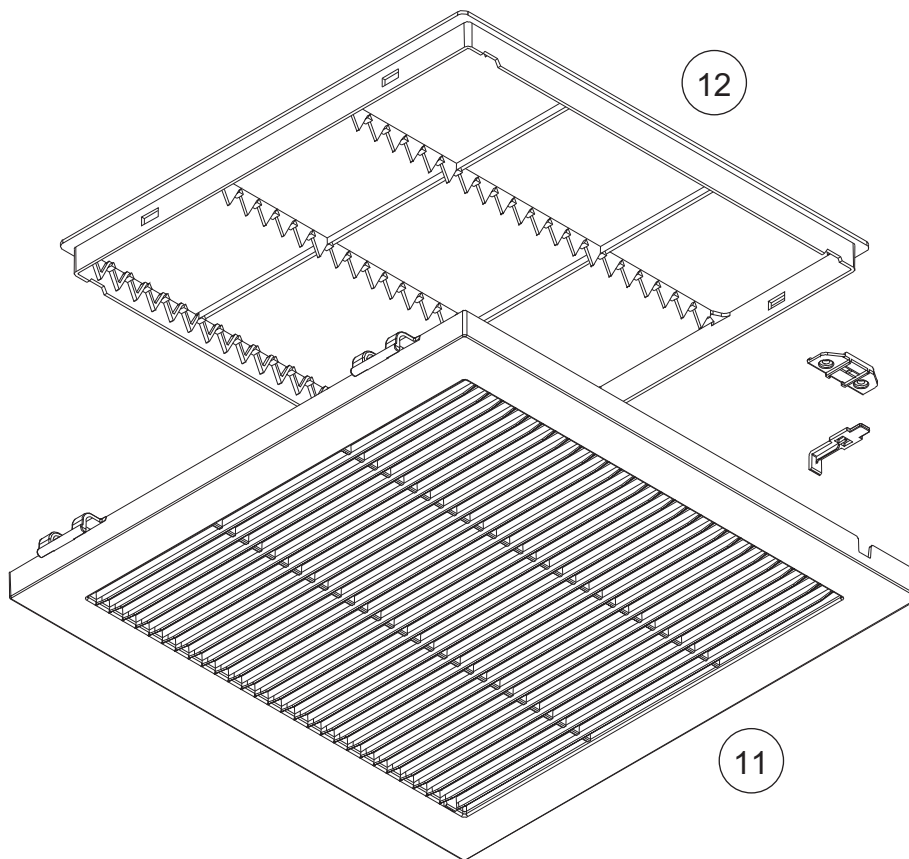

Ref	Description	Parts No.
11	Intake grille	9382863005
12	Long Life Filter	9375533014
13	Hook bracket	9375546014
14	Grille hook	9375532031

■ Louvers and motors

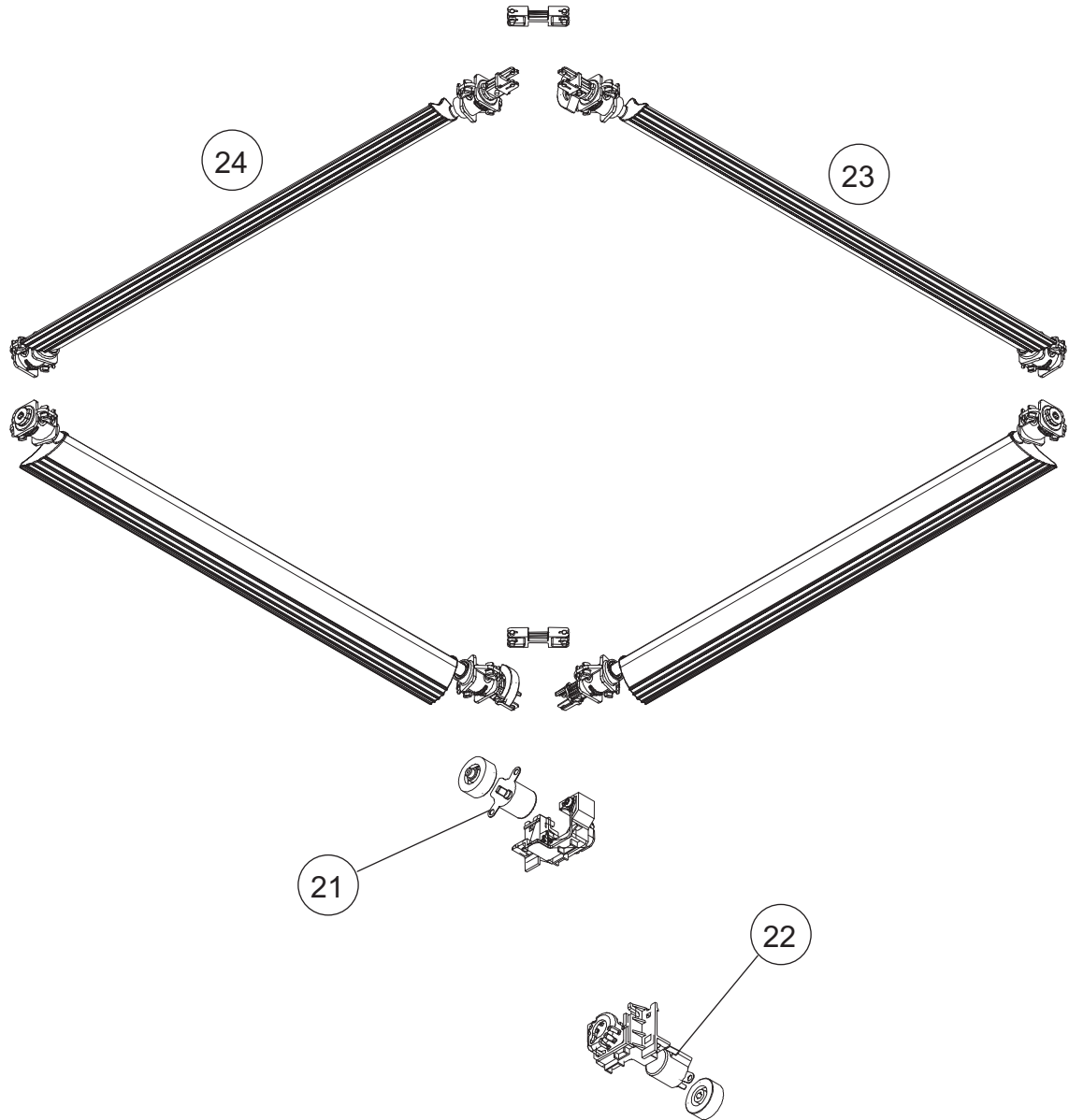

Ref	Description	Parts No.
21	Step Motor (White connector)	9900139070
22	Step Motor (Red connector)	9900139087
23	Flap assy A	9375727048
24	Flap assy B	9377759047

3. Indoor unit parts list

3-1. Models: AUXG18KVLA, AUXG22KVLA, and AUXG24KVLA

TECHNICAL DATA
AND PARTS LIST

TECHNICAL DATA
AND PARTS LIST

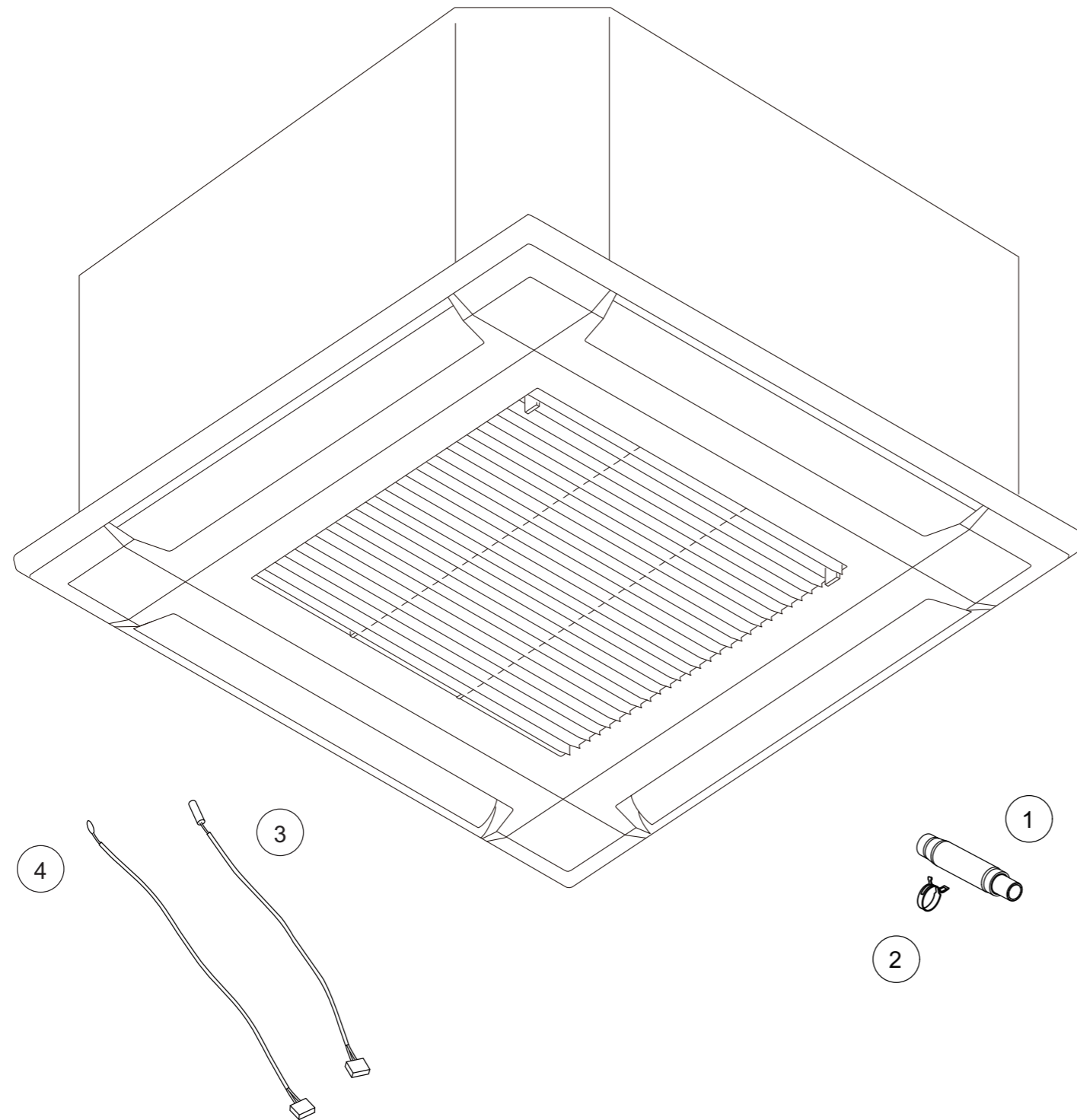

Ref.	Description	Part number
1	Drain hose	9379665001
2	Hose band	9379757010
3	Pipe Thermistor	9900942038
4	Room Thermistor	9900826000

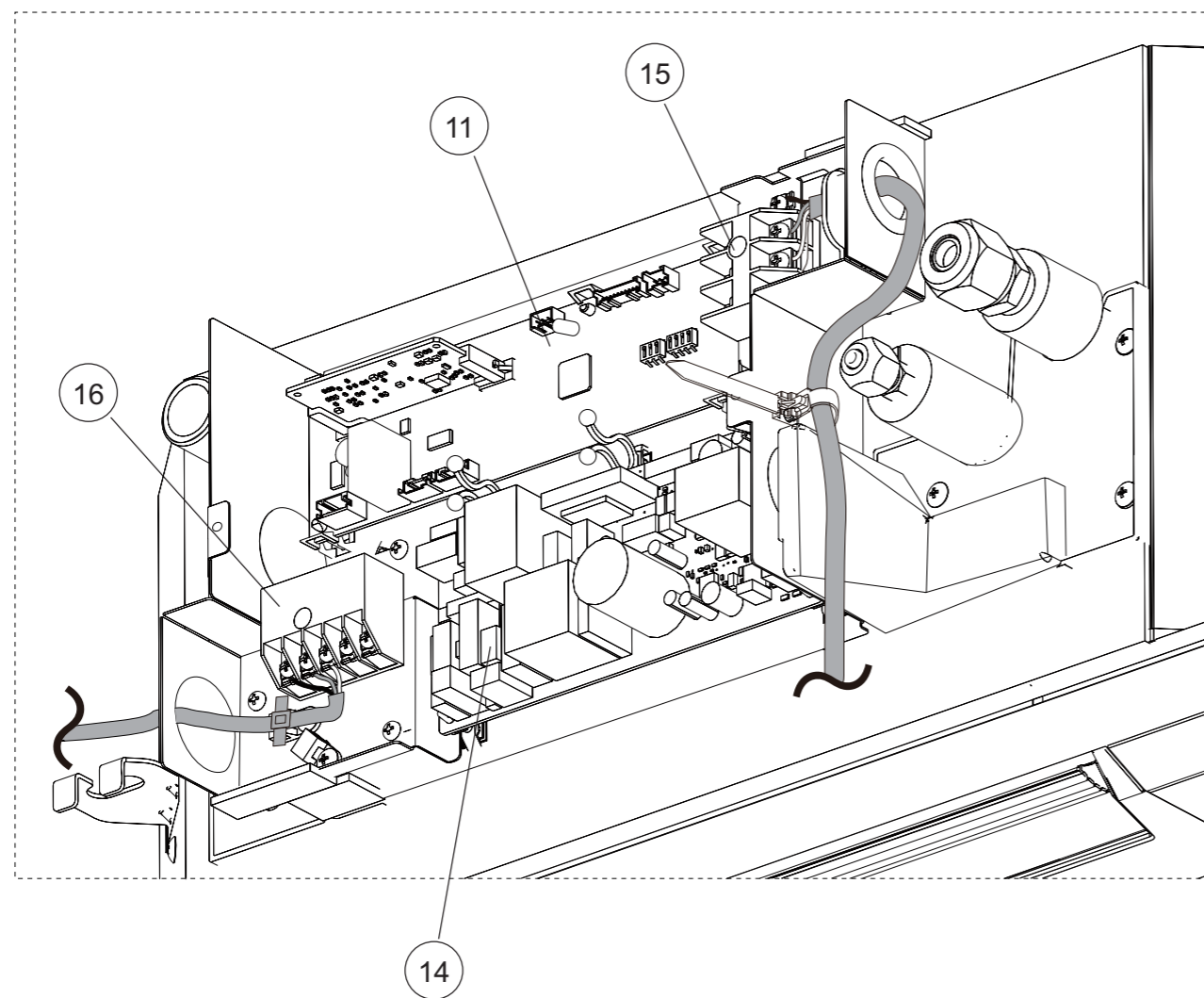
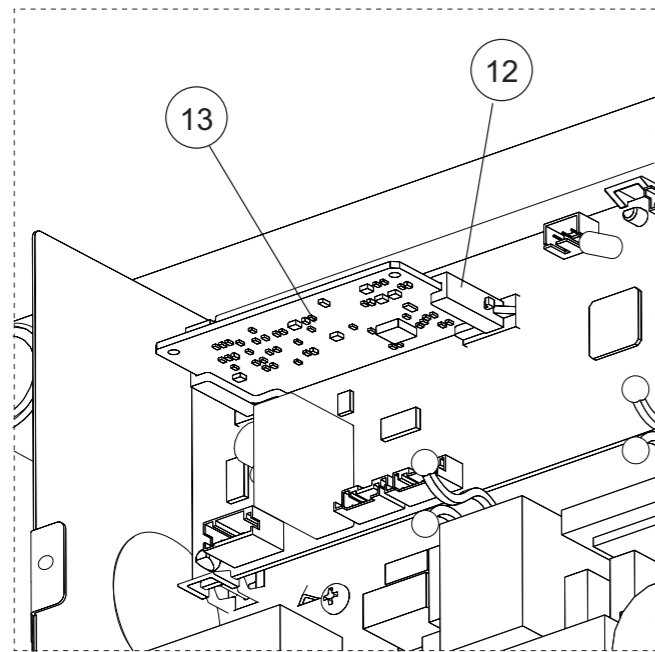

Ref.	Description	Part number
11	Main PCB (07)	9710995965
11	Main PCB (09)	9710995743
11	Main PCB (12)	9710995750
11	Main PCB (14)	9710995705
11	Main PCB (18)	9710995767
11	Main PCB (22)	9710995613
11	Main PCB (24)	9710995866
12	Holder	0600063023
13	Communication PCB	9710019005
14	Power supply PCB	9710661006
15	Terminal	9900568009
16	Terminal	9900896003

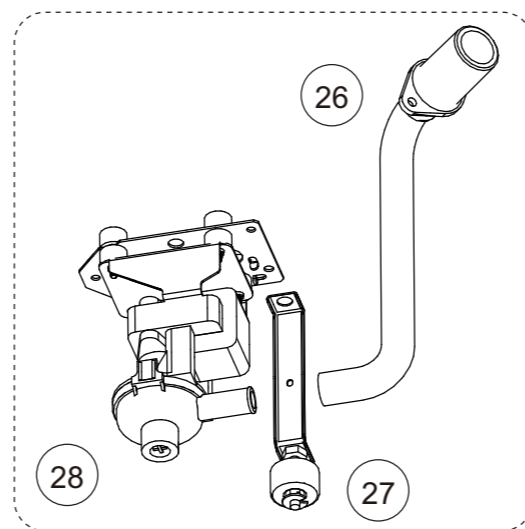
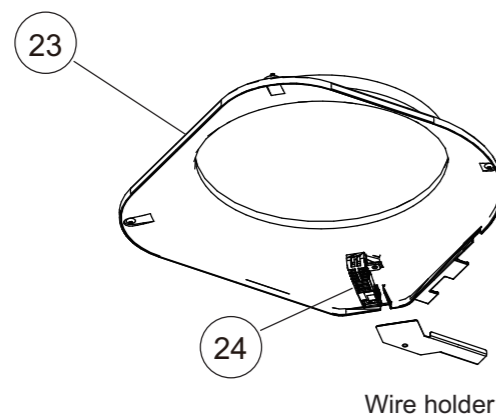
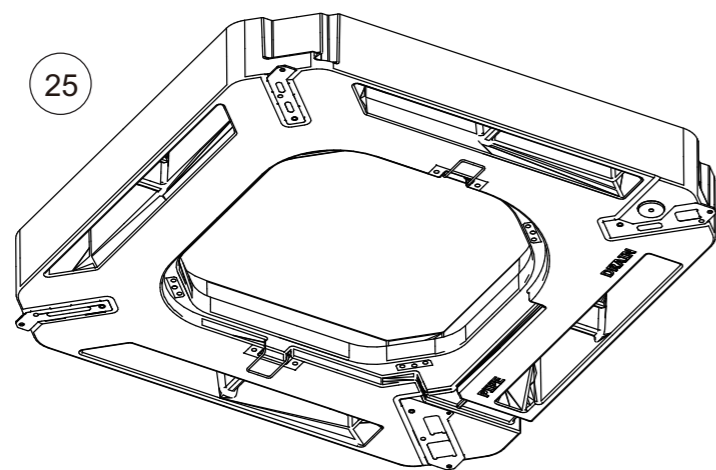
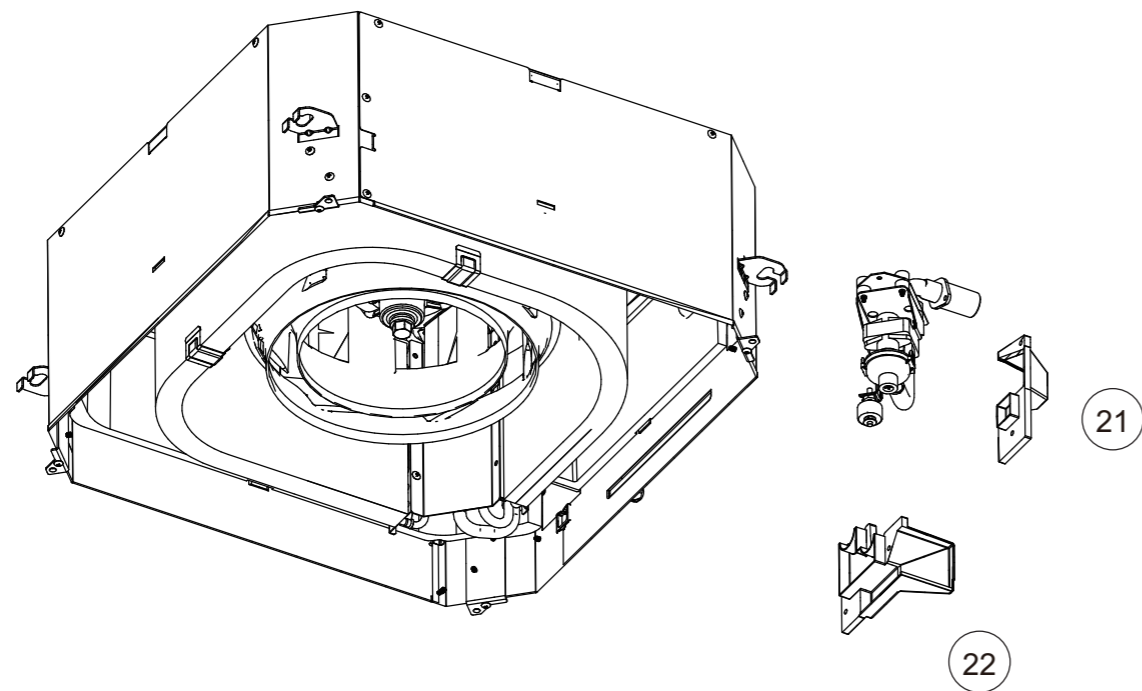

Ref.	Description	Part number
21	Wire cover	9375516017
22	Pipe cover	9375515010
23	Bellmouth	9375503017
24	Thermistor holder	9375477011
25	Drain pan sub assy (18)	9377765024
25	Drain pan sub assy (22, 24)	9377765017
26	Drain port sub assy	9375718015
27	Float Switch sub assy	9375721046
28	Drain pump sub assy	9375717025

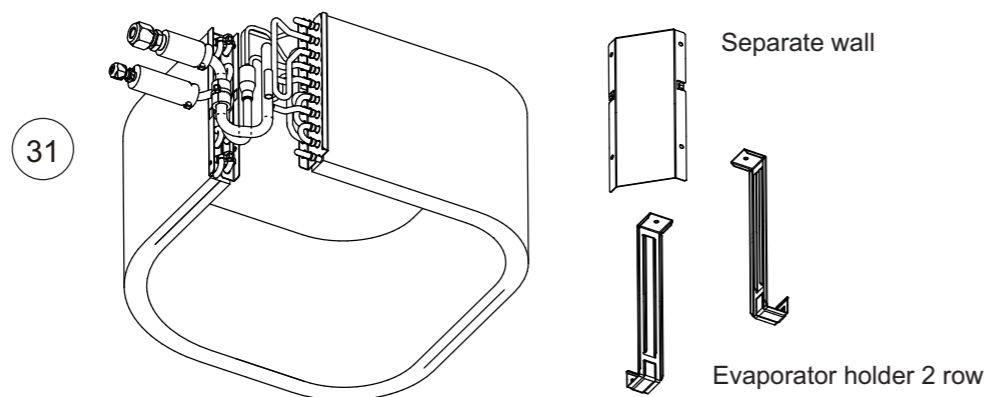
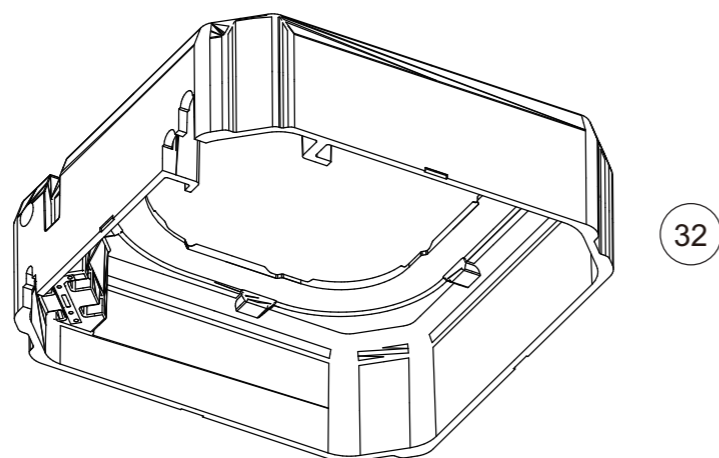
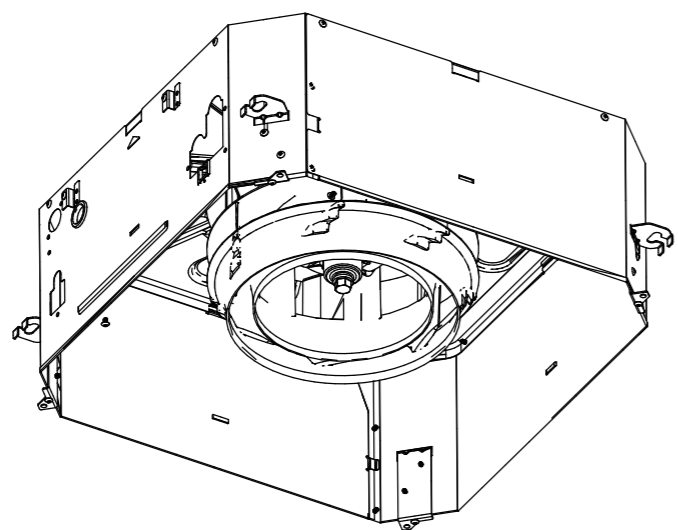

Ref.	Description	Part number
31	Evaporator total assy (07)	9377914156
31	Evaporator total assy (09, 12)	9377914101
31	Evaporator total assy (14)	9377914118
31	Evaporator total assy (18)	9377914125
31	Evaporator total assy (22, 24)	9377914149
32	Insulation box sub assy (07-18)	9377764065
32	Insulation box sub assy (22, 24)	9377764058

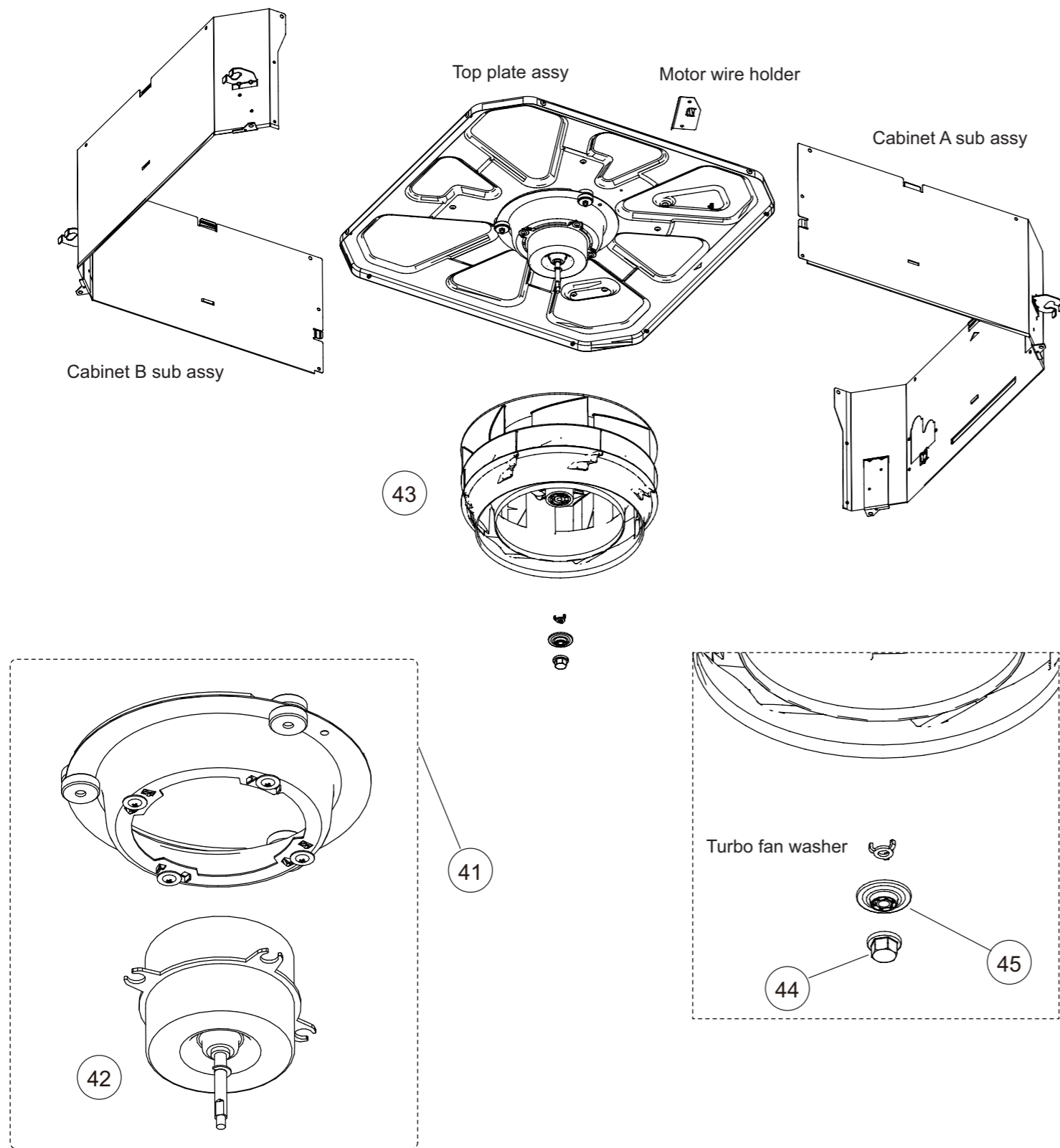

Ref.	Description	Part number
41	Fan motor sub Assy	9375719012
42	Fan motor	9602436019
43	2 stage turbo fan Assy	9375480011
44	Shaft cap	9377807014
45	Washer cover	9377811011

3-2. Model: ARXG18KLLAP

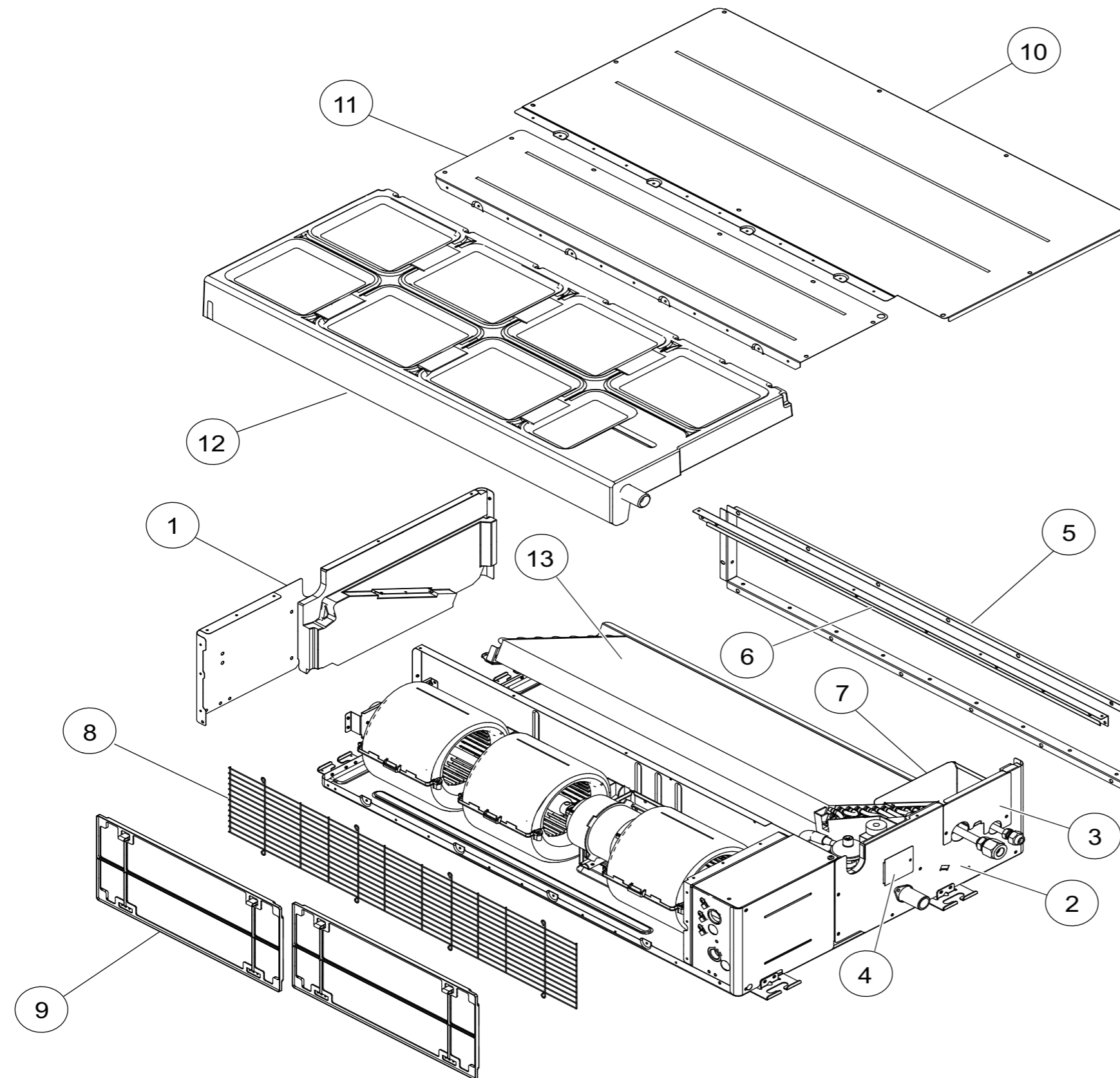

Ref	Description	Parts number
1	Side Panel R Sub Assy	9379906012
2	Side Panel L Sub Assy	9379907019
3	Pipe Panel Sub Assy	9379900003
4	Panel (Window) Sub Assy	9379915007
5	Outlet Frame Assy	9380042013
6	Front Panel (3 Fan)	9380595007
7	Valve Cover Sub Assy	9379576017
8	Fan Guard (3 Fan)	9380590002
9	Air Filter	9379575003
10	Main Panel (3 Fan)	9380603016
11	Cabinet Panel (3 Fan)	9380598008
12	Drain Pan Sub Assy	9379901178
13	Evaporator Total Assy (18)	9380682493

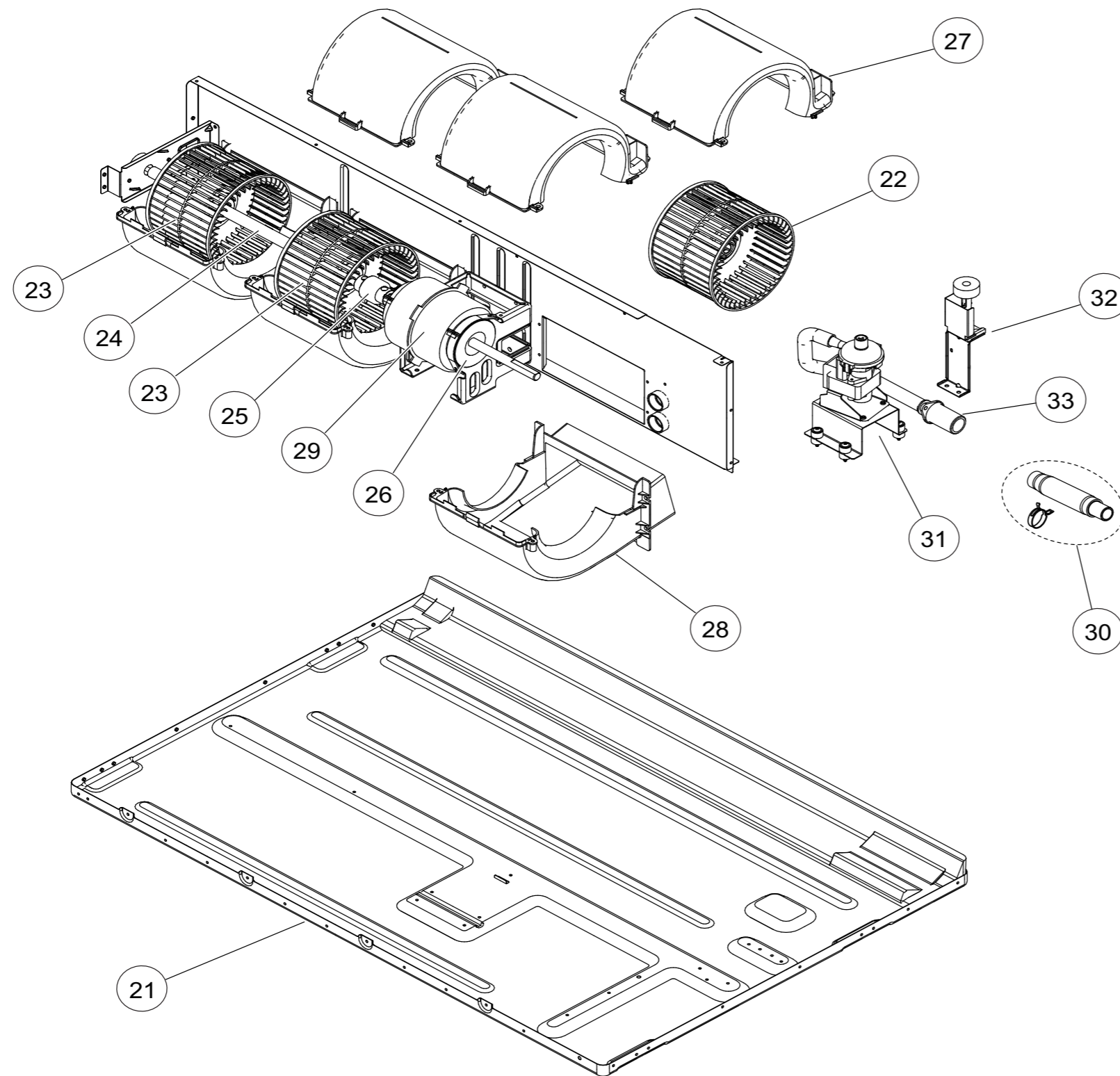

Ref	Description	Parts number
21	Top Panel Sub Assy	9379908047
22	Sirroco Fan Assy	9379570022
23	Sirroco Fan Assy	9379570039
24	Shaft assy	9381052004
25	Joint Assy	9378038011
26	Rubber (Vibration Proof)	9379644006
27	Casing B	9379572019
28	Casing U	9379571012
29	Fan Motor Assy	9379047142
30	Hose Sub Assy	9378450097
31	Drain Pump Sub Assy	9379914062
32	Float Switch Sub Assy	9378593039
33	Drain Hose Assy	9379913003

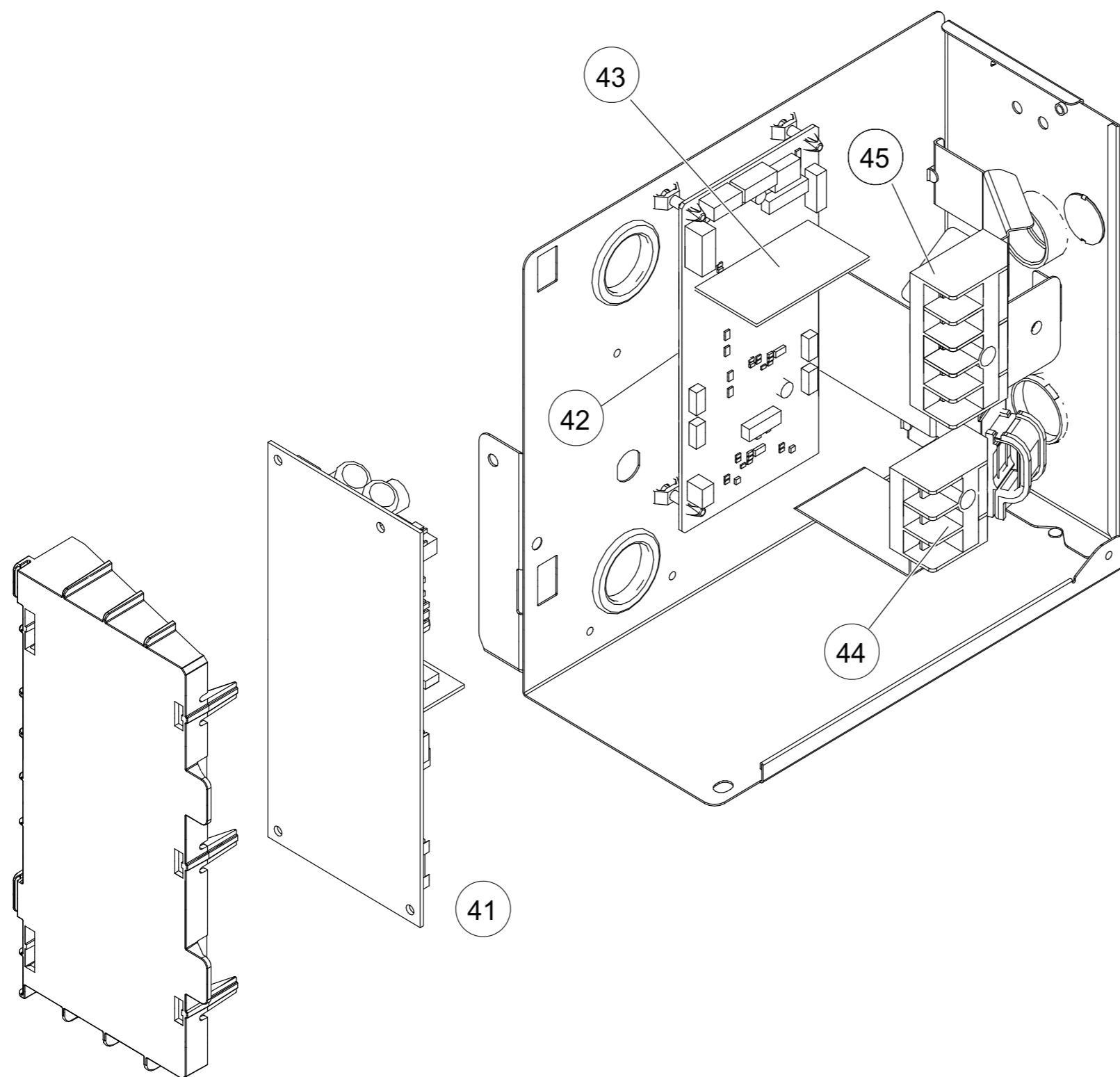

Ref	Description	Parts number
41	Power Supply PCB	9710661006
42	Main PCB	9710624131
43	2 way Remote PCB	9710019005
44	Terminal 3P	9900568009
45	Terminal 3P (Wired Remote)	9900896003
--	Room Thermistor	9900653019
--	Pipe Thermistor	9900942045

3-3. Models: ARXG22KMLA and ARXG24KMLA

Hook metal

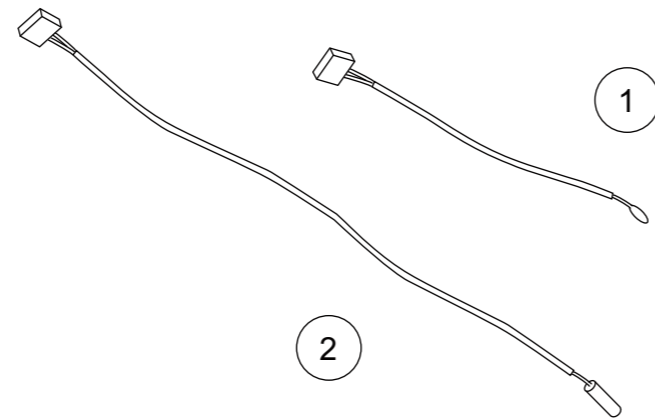
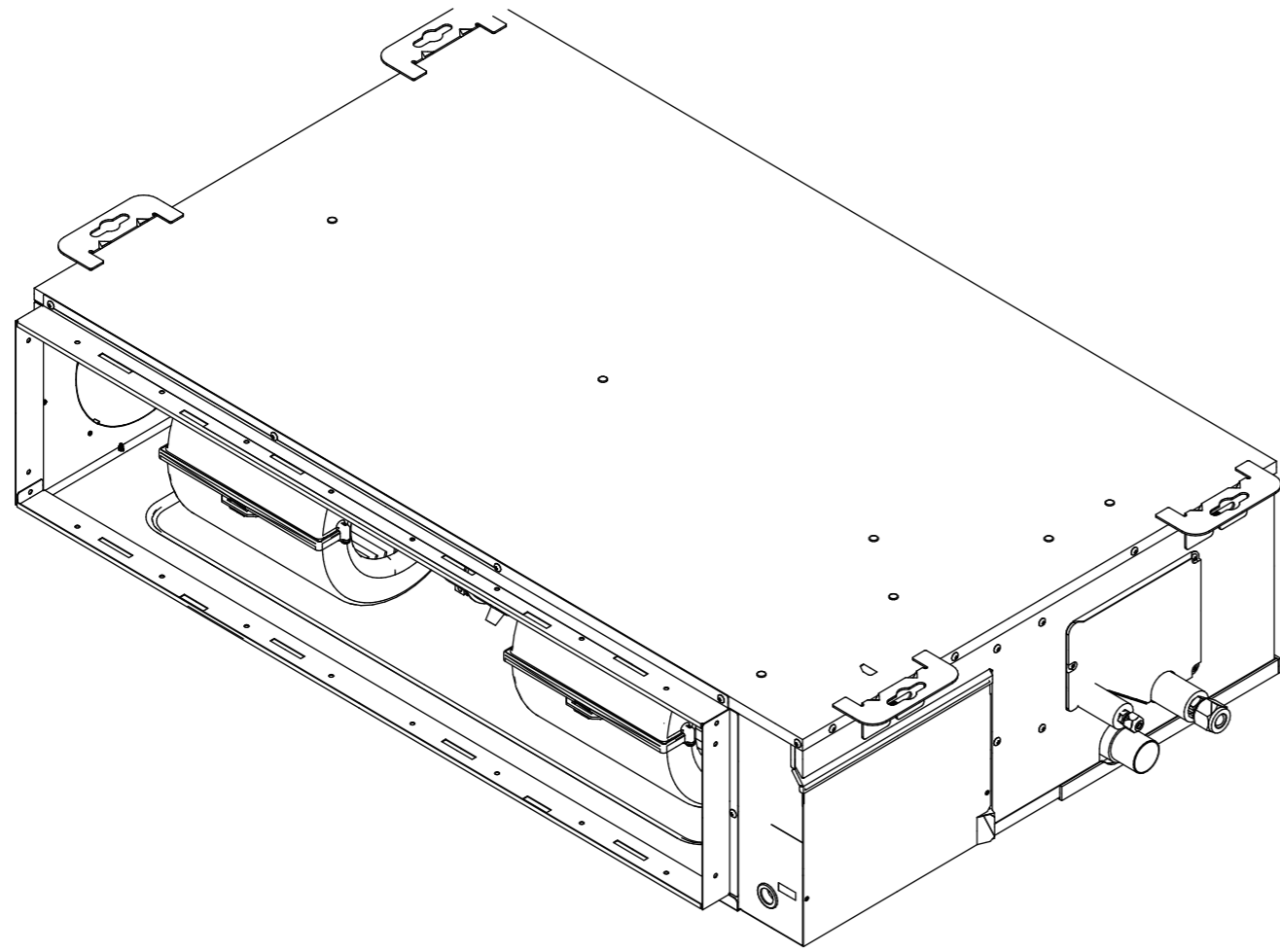

Ref.	Description	Part number
1	Room thermistor	9900826048
2	Pipe thermistor	9900942045

TECHNICAL DATA
AND PARTS LIST

TECHNICAL DATA
AND PARTS LIST

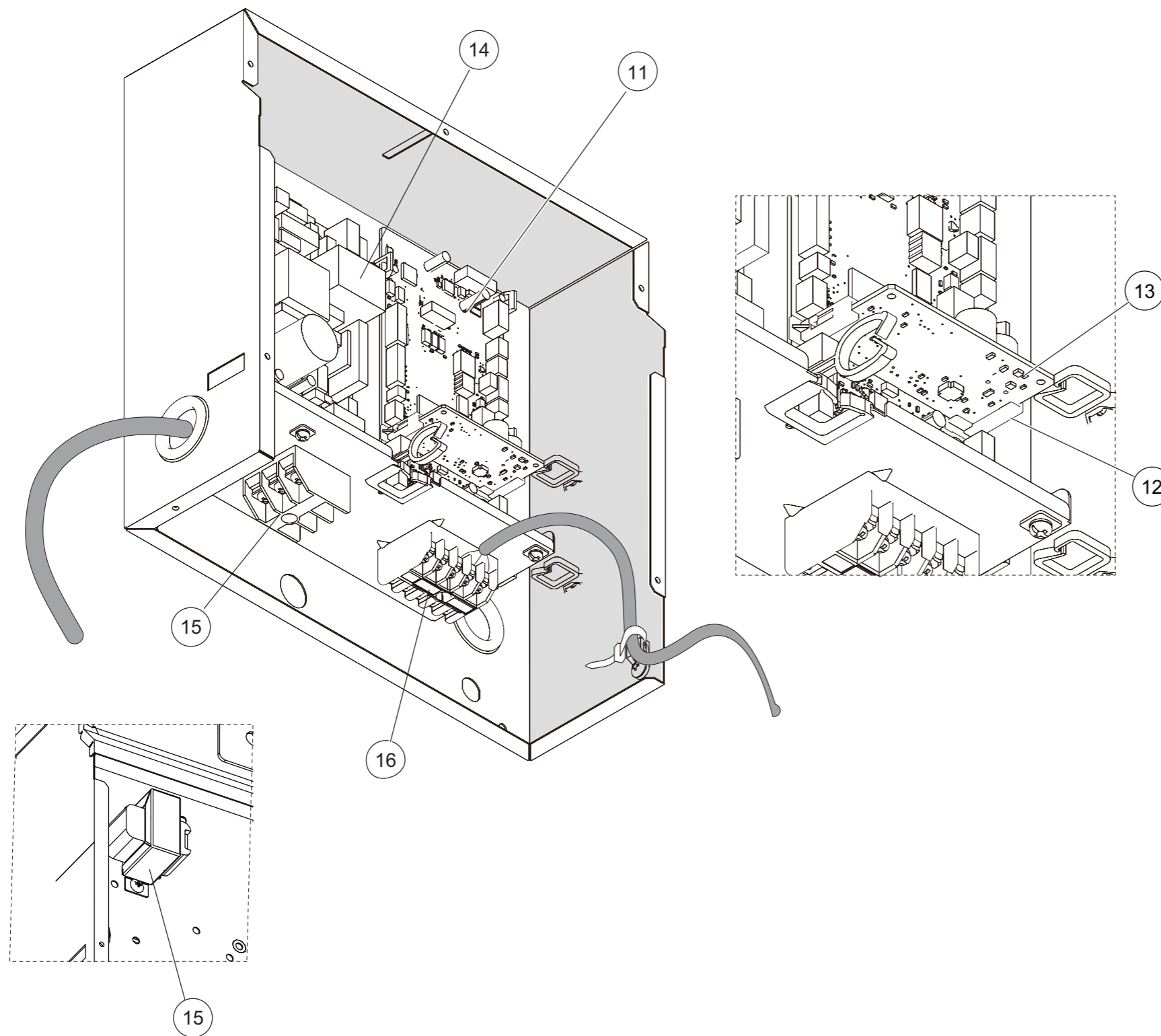

Ref.	Description	Part number
11	Main PCB (22)	9710624124
11	Main PCB (24)	9710624223
12	Holder	0600063023
13	Communication PCB	9710019005
14	Power supply PCB	9710661013
15	Terminal 3P	9306489045
16	Terminal 5P	9900896003
17	Reactor assy	9707457049

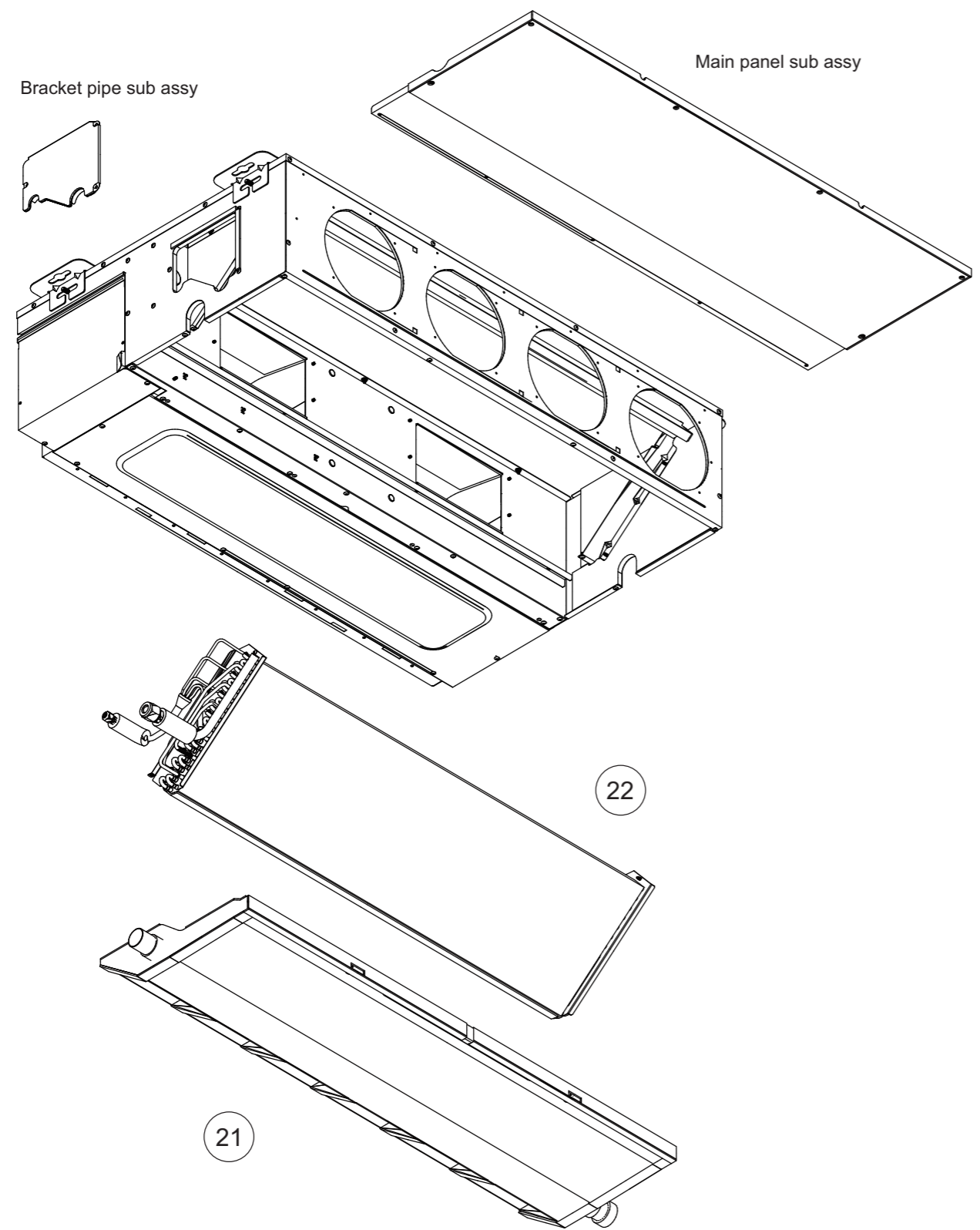

Ref.	Description	Part number
21	Drain pan sub assy	9374513017
22	Evaporator Total Assy	9374517978

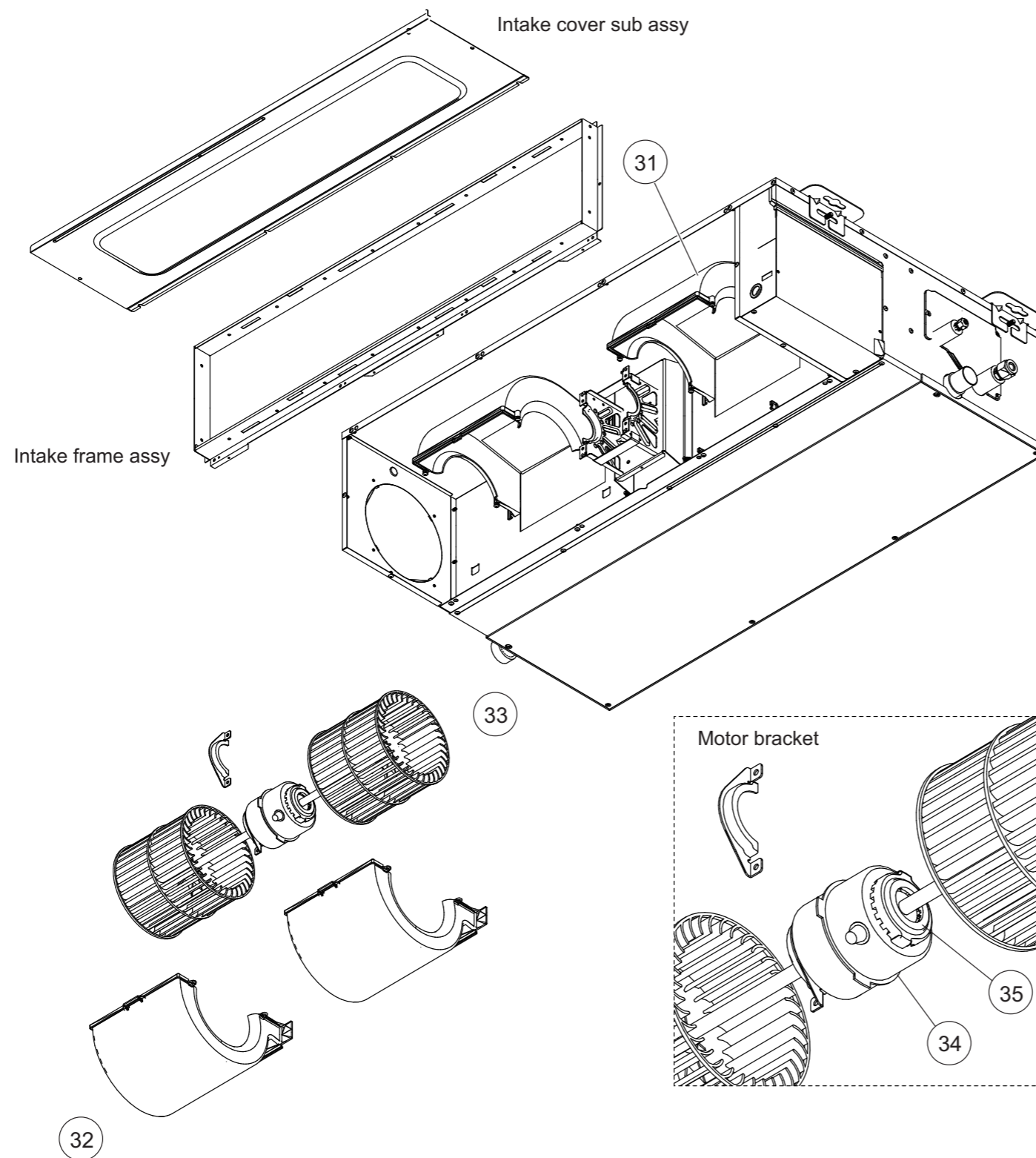

Ref.	Description	Part number
31	Casing A	9374233021
32	Casing B	9374234028
33	Sirocco fan assy	9356531060
34	Fan motor assy	9380718031
35	Rubber	9385102002

4. Outdoor unit parts list

4-1. Model: AOYG36KRTA

■ Exterior parts and chassis

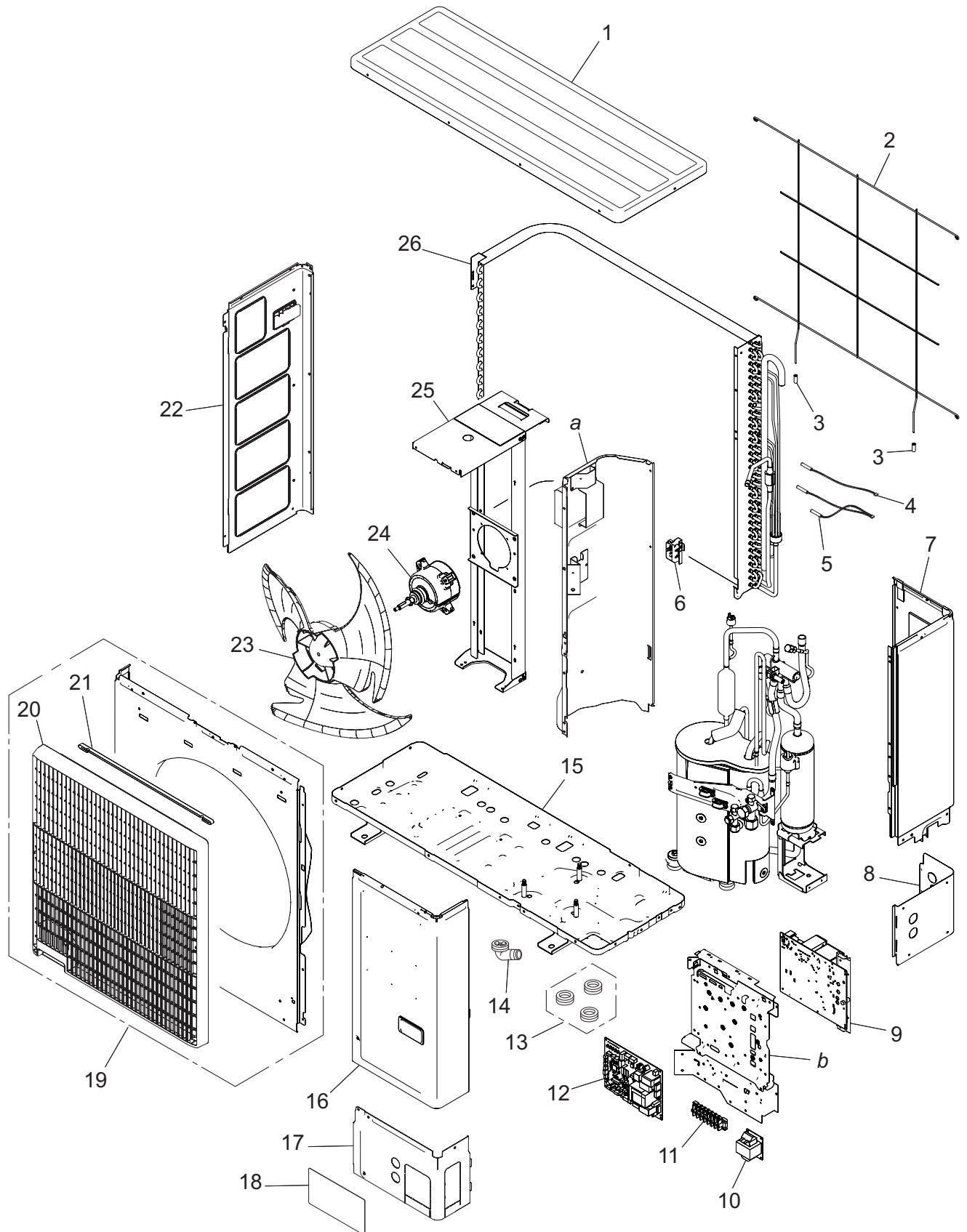

TECHNICAL DATA
AND PARTS LIST

TECHNICAL DATA
AND PARTS LIST

Item no.	Part no.	Part name	Service part
1	9383880001	Top panel assy	◆
2	9383779008	Protective net	◆
3	9375361013	Net rubber	◆
4	9900984038	Thermistor (Heat exchanger)	◆
5	9900727154	Thermistor assy	◆
6	9383607004	Thermo holder	◆
7	9383874000	Right panel sub assy	◆
8	9383879005	Rear pipe cover	◆
9	9711424006	Inverter PCB	◆
10	9900634025	Reactor assy	◆
11	9901053016	Terminal	◆
12	9711431080	Main PCB (Service)	◆
13	313166024302	Drain cap	◆
14	9303029015	Drain assy	◆
15	9383871009	Base assy	◆
16	9383876004	Service panel sub assy	◆
17	9383878008	Front pipe cover	◆
18	9351355005	Emblem rear	◆
19	9383863004	Front panel assy	◆
20	9383604003	Blow grille	◆
21	9383689000	Blow grille insulation	◆
22	9383882005	Left panel sub assy	◆
23	9383336003	Propeller fan	◆
24	9603732011	Brushless motor	◆
25	9383862007	Motor bracket assy	◆
26	9374420612	Condenser sub assy	◆
<i>a</i>	—	Separate wall assy	—
<i>b</i>	—	Control box unit	—

Compressor

TECHNICAL DATA
AND PARTS LIST

TECHNICAL DATA
AND PARTS LIST

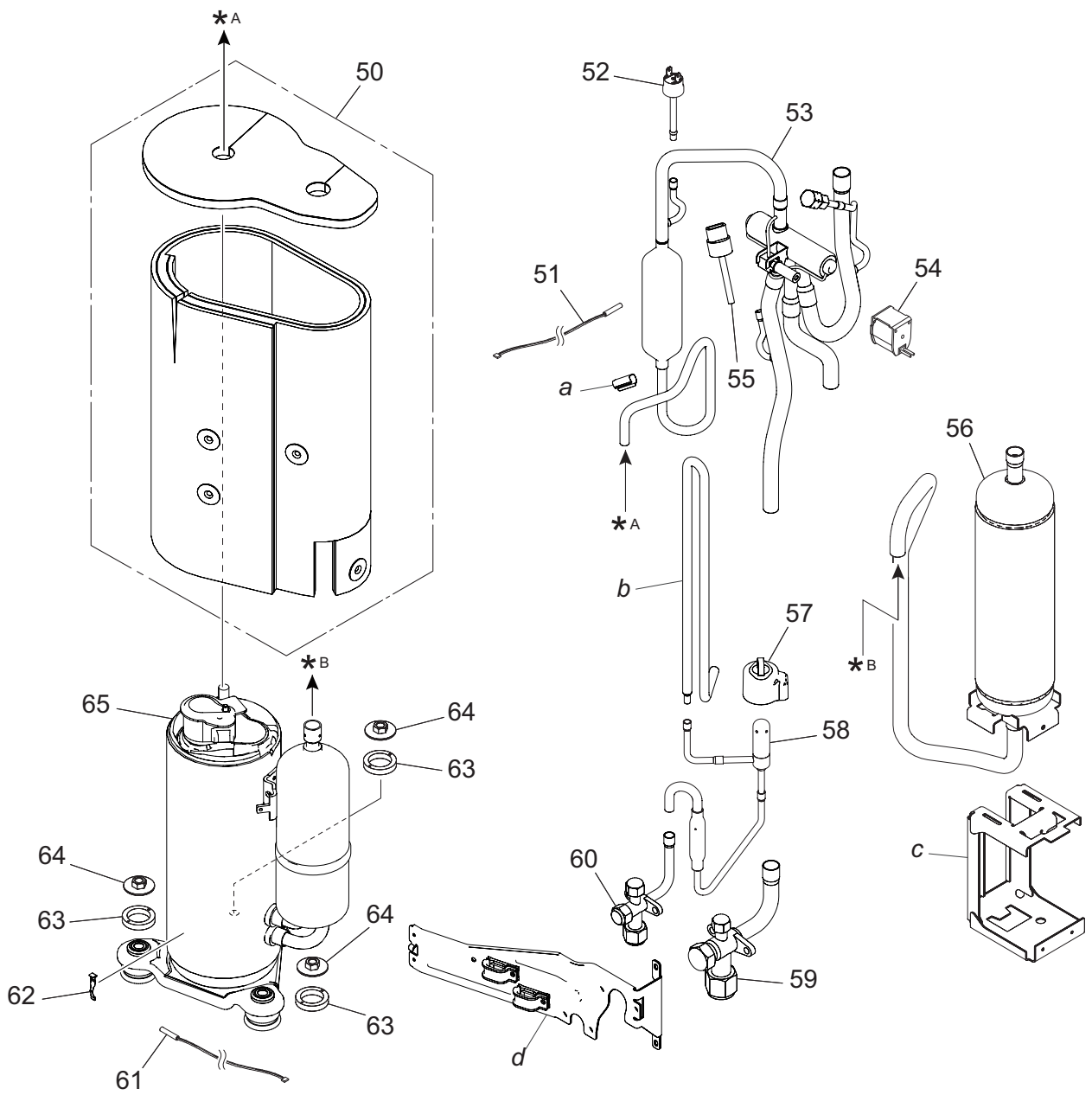

Item no.	Part no.	Part name	Service part
50	9383858000	Sound insulation unit	◆
51	9900565091	Thermistor (Outdoor temp.)	◆
52	9900186029	Pressure switch	◆
53	9374425631	4-way valve assy	◆
54	9970194016	Solenoid	◆
55	9970158018	Sensor	◆
56	9375250140	Accumulator assy	◆
57	9970209000	Expansion valve coil	◆
58	9370947328	Expansion valve assy	◆
59	9379079013	3-way valve assy	◆
60	9377958037	3-way valve assy	◆
61	9900985035	Thermistor (Compressor)	◆
62	9810028006	Thermistor stopper	◆
63	9379179065	Rubber washer C	◆
64	9377973016	Special nut	◆
65	9383821011	Compressor assy	◆
<i>a</i>	—	Thermostat holder	—
<i>b</i>	—	Joint pipe D	—
<i>c</i>	—	Accumulator holder A	—
<i>d</i>	—	Wiring fixation unit	—

4-2. Models: AOYG45KRTA and AOYG54KRTA

■ Exterior parts and chassis

TECHNICAL DATA
AND PARTS LIST

TECHNICAL DATA
AND PARTS LIST

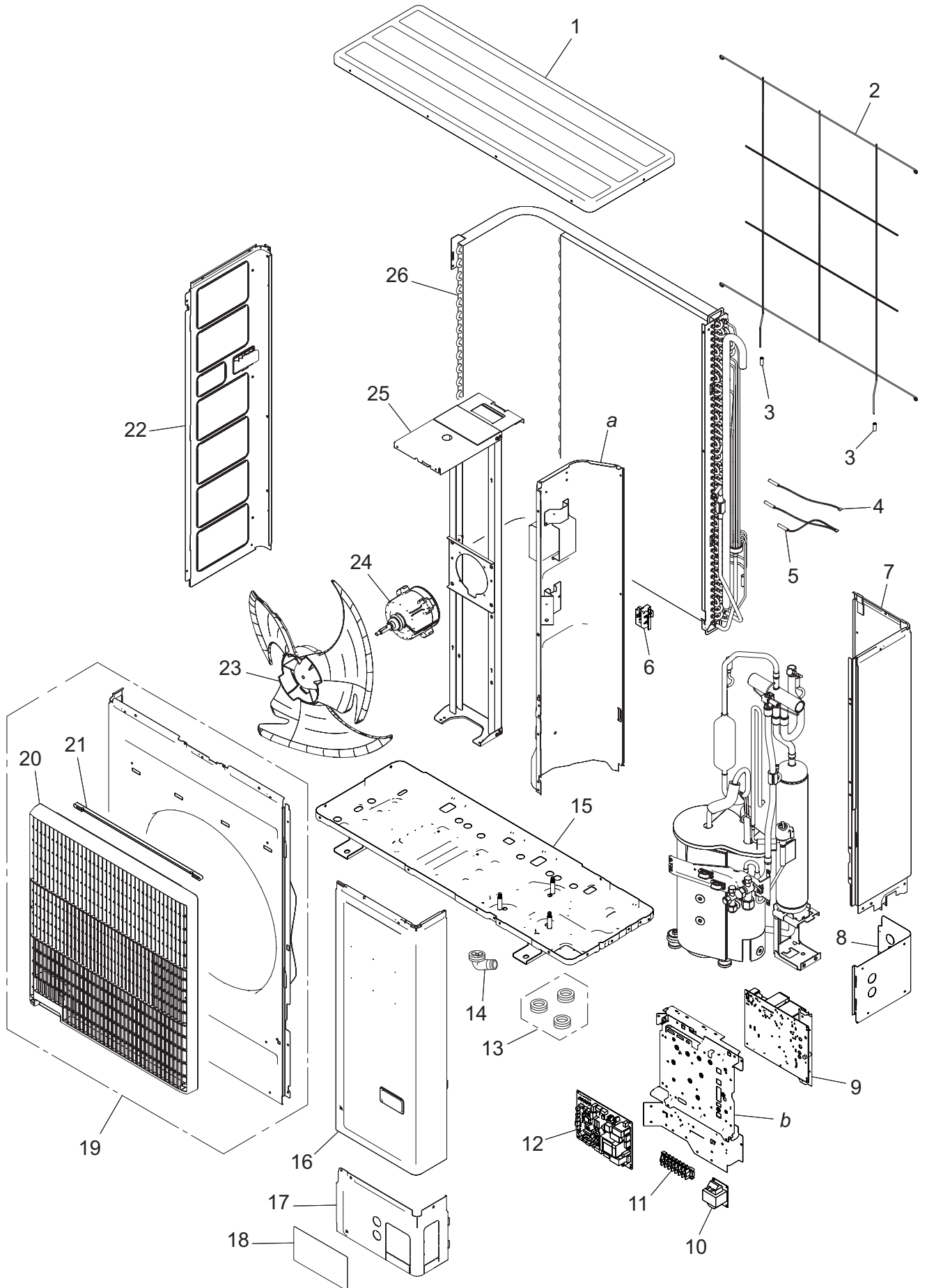

Item no.	Part no.	Part name	Service part
1	9383880001	Top panel assy	◆
2	9381013005	Protective net	◆
3	9375361013	Net rubber	◆
4	9900984038	Thermistor (Heat exchanger)	◆
5	9900727154	Thermistor assy	◆
6	9383607004	Thermo holder	◆
7	9383874017	Right panel sub assy	◆
8	9383879005	Rear pipe cover	◆
9	9711424013	Inverter PCB	◆
10	9900634025	Reactor assy	◆
11	9901053016	Terminal	◆
12	9711431097	Main PCB (Service) (for 45 model)	◆
	9711431103	Main PCB (Service) (for 54 model)	◆
13	313166024302	Drain cap	◆
14	9303029015	Drain assy	◆
15	9383871009	Base assy	◆
16	9383876011	Service panel sub assy	◆
17	9383878008	Front pipe cover	◆
18	9351355005	Emblem rear	◆
19	9383863011	Front panel assy	◆
20	9383604003	Blow grille	◆
21	9383689000	Blow grille insulation	◆
22	9383882012	Left panel sub assy	◆
23	9383336003	Propeller fan	◆
24	9603733018	Brushless motor	◆
25	9383862014	Motor bracket assy	◆
26	9374420605	Condenser sub assy	◆
<i>a</i>	—	Separate wall assy	—
<i>b</i>	—	Control box unit	—

Compressor

TECHNICAL DATA
AND PARTS LIST

TECHNICAL DATA
AND PARTS LIST

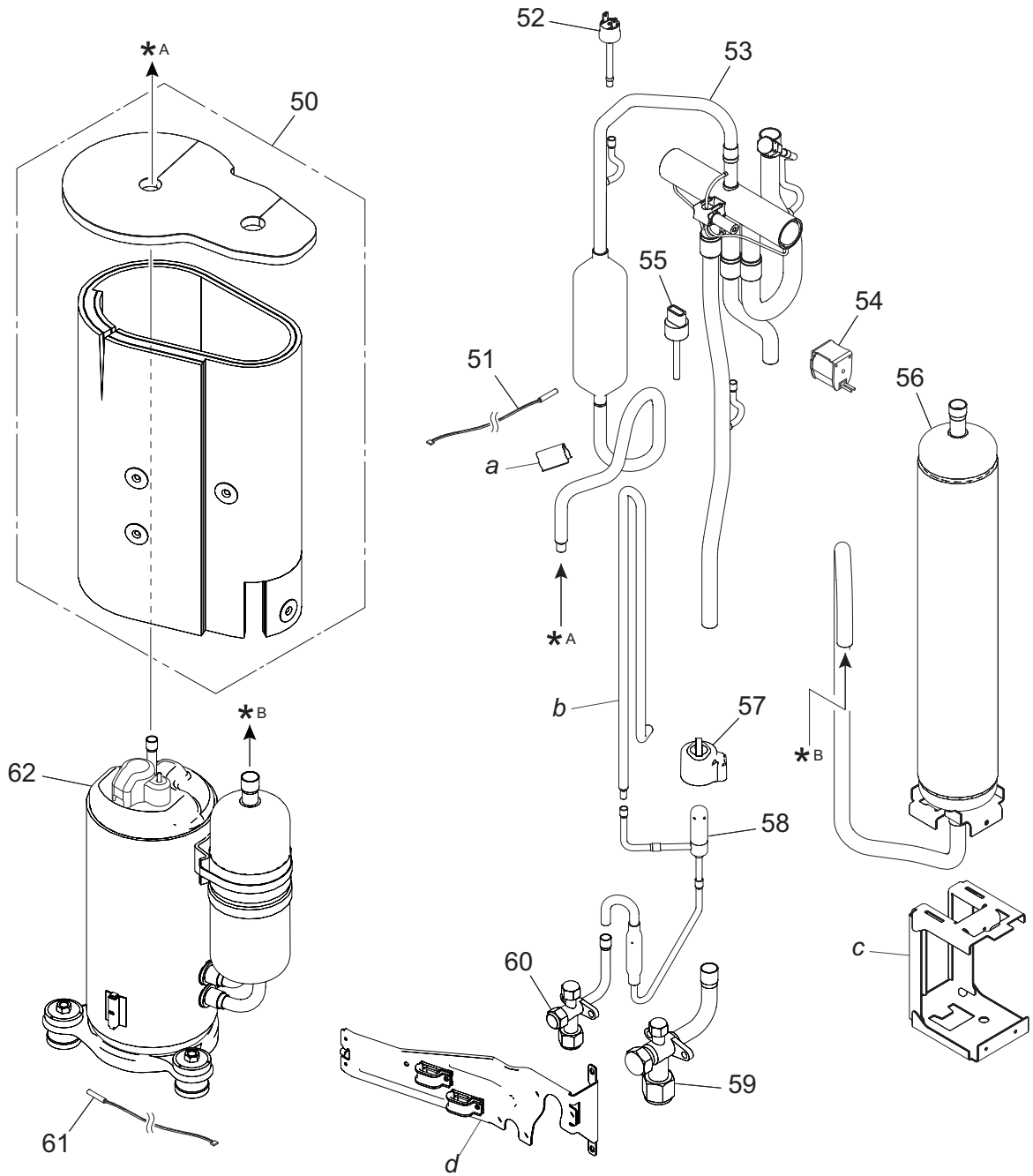







Item no.	Part no.	Part name	Service part
50	9383858017	Sound insulation unit	◆
51	9900565091	Thermistor (Outdoor temp.)	◆
52	9900186029	Pressure switch	◆
53	9374425624	4-way valve assy	◆
54	9970194016	Solenoid	◆
55	9970158018	Sensor	◆
56	9375250133	Accumulator assy	◆
57	9970209000	Expansion valve coil	◆
58	9370947311	Expansion valve assy	◆
59	9379079013	3-way valve assy	◆
60	9377958037	3-way valve assy	◆
61	9900985028	Thermistor (Compressor)	◆
62	9383851025	Compressor unit	◆
<i>a</i>	—	Thermistor spring	—
<i>b</i>	—	Joint pipe D	—
<i>c</i>	—	Accumulator holder A	—
<i>d</i>	—	Wiring fixation unit	—

5. Accessories

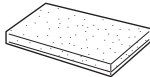
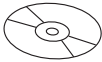
5-1. Indoor unit

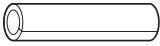
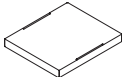
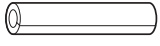



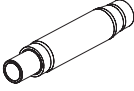

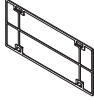
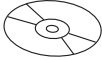
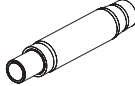

■ Compact cassette type

● Models: AUXG18KVLA, AUXG22KVLA, and AUXG24KVLA

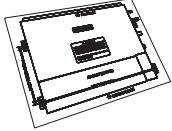
Part name	Exterior	Q'ty	Part name	Exterior	Q'ty
Operating manual		1	Drain hose insulation		1
Operating manual (CD-ROM)		1	Hose band		1
Installation manual		1	Coupler heat insulation (large)		1
Template (Carton top)		1	Coupler heat insulation (small)		1
M10 nut A (with flange)		4	Cable tie		2
M10 nut B (with spring lock washer)		4	Wire crammer		1
Drain hose		1			



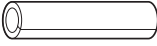

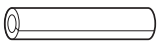





■ Slim duct type

● Model: ARXG18KLLAP

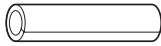
Part name	Exterior	Q'ty	Part name	Exterior	Q'ty
Operating manual		1	Filter (large)		2
Operating manual (CD-ROM)		1	Drain hose		1
Installation manual		1	Hose band		1
Installation template		1	Drain hose insulation B		1
Washer		8	Insulation (for electrical wiring)		2
Cable tie (large)		4	Coupler heat insulation (large)		1
Cable tie (medium)		3	Coupler heat insulation (small)		1

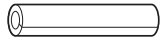
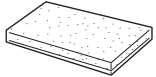



■ Duct type

● Models: ARXG22KMLA and ARXG24KMLA

Part name	Exterior	Q'ty	Part name	Exterior	Q'ty
Operating manual		1	Cable tie (Small)		1
Installation manual		1	Cable tie		1
CD-ROM		1	Coupler heat insulation (Large)		1
Hanger		4	Coupler heat insulation (Small)		1
Drain hose insulation		1	M10 nut A (with flange)		4
Cable tie (Large)		1	M10 nut B (with spring lock washer)		4

5-2. Outdoor unit

■ Models: AOYG36KRTA, AOYG45KRTA, and AOYG54KRTA

Part name	Exterior	Q'ty	Part name	Exterior	Q'ty
Installation manual		1	Drain cap		3
Drain pipe		1	One-touch bush		2

6. Optional parts

6-1. Branch pipes

■ Model: UTP-SX236A

Unit: mm

Port diameters			
Liquid pipe	Q'ty	Gas pipe	Q'ty
	1		1

Dimensions	
Liquid pipe	Gas pipe

Heat insulation cover			
Liquid pipe	Q'ty	Gas pipe	Q'ty
	1		1

TECHNICAL DATA
AND PARTS LIST

TECHNICAL DATA
AND PARTS LIST

■ Model: UTP-SX354A

Unit: mm

TECHNICAL DATA
AND PARTS LIST

TECHNICAL DATA
AND PARTS LIST

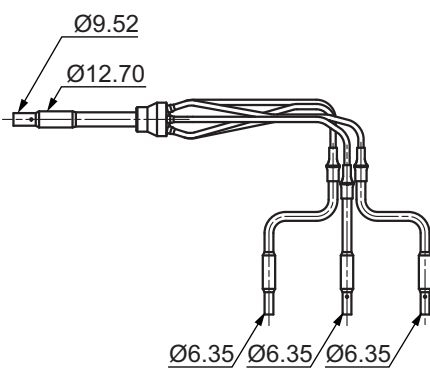
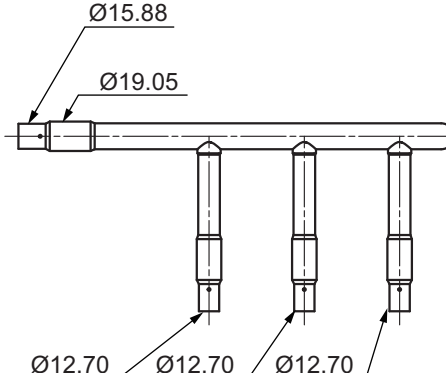
Port diameters			
Liquid pipe	Q'ty	Gas pipe	Q'ty
	1		1

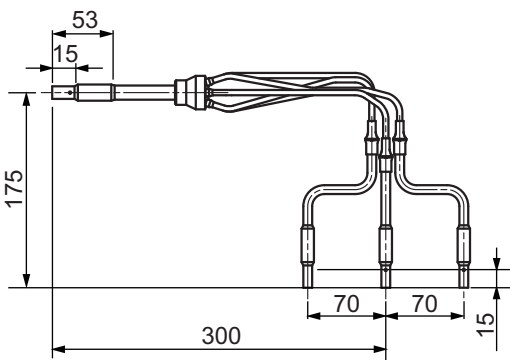
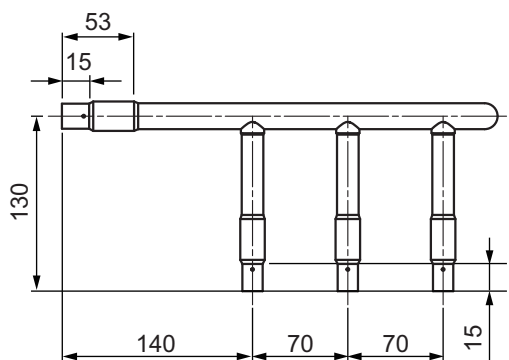
Dimensions	
Liquid pipe	Gas pipe
	

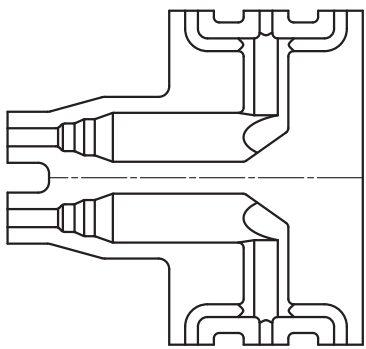
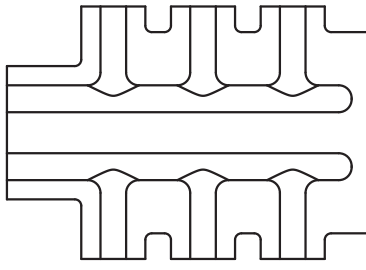
Heat insulation cover			
Liquid pipe	Q'ty	Gas pipe	Q'ty
	1		1

Others	
Cable tie	Q'ty
	1

6-2. Controllers

Lineup

Indoor unit type	Type		
	Wired remote controller		Simple remote controller
	UTY-RNNYM	UTY-RVNYM	UTY-RSNYM
Compact cassette	○	○	○
Slim duct	○	○	○
Duct	○	○	○



Indoor unit type	Type	
	Wireless remote controller	IR receiver kit with Wireless remote controller
	UTY-LNTY	UTY-LBTYM
Compact cassette	○	—
Slim duct	—	○
Duct	—	○

○: Optional, —: Not applicable

NOTE: 2-wire remote controller is not available for this product.

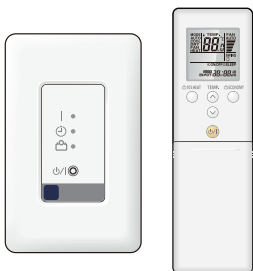
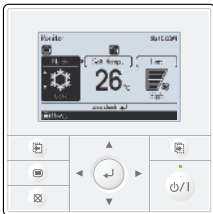
Parts

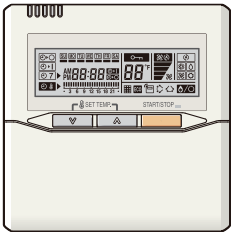
Exterior	Part name	Model name	Summary
	Wireless remote controller	UTY-LNTY	Unit control is performed by wireless remote controller.
	IR receiver kit with wireless remote controller	UTY-LBTYM	Unit control is performed by wireless remote controller.
	Wired remote controller	UTY-RVNYM	Large and full-dot liquid crystal screen, wide and large keys easy to press, user-intuitive arrow key. Wire type: Polar 3-wire

Exterior	Part name	Model name	Summary
	Wired remote controller	UTY-RNNYM	Room temperature can be controlled by detecting the temperature accurately with built-in thermo sensor. Wire type: Polar 3-wire
	Simple remote controller	UTY-RSNYM	Compact remote controller concentrates on the basic functions such as Start/Stop, fan control, temperature setting, and operation mode. Wire type: Polar 3-wire

NOTE: Available functions may differ by the remote controller. For details, refer to the operation manual.

6-3. Cassette grille

■ Parts

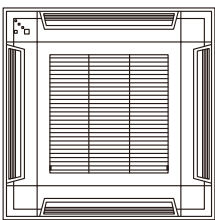

Exterior	Part name	Model name	Summary
	Cassette grille	UTG-UFYF-W	This cassette grille can be installed appropriately on the grid type ceiling common in the office.





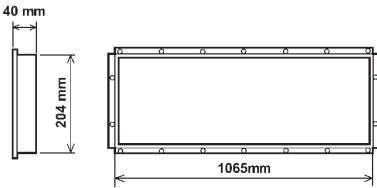
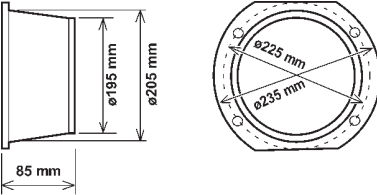
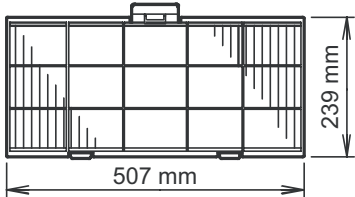

6-4. Others

Lineup

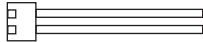
Type	Model	Indoor unit			Outdoor unit
		Compact cassette	Slim duct	Duct	
Air outlet shutter plate	UTR-YDZB	○	—	—	—
Insulation kit for high humidity	UTZ-KXGC	○	—	—	—
Fresh air intake kit	UTZ-VXAA	○	—	—	—
Square flange	UTD-SF045T	—	—	○	—
Round flange	UTD-RF204	—	—	○	—
Long-life filter	UTD-LF25NA	—	—	○	—
Remote sensor unit	UTY-XSZX	—	○	○	—
Auto louver grille kit	UTD-GXTB-W	—	○	—	—
Drain pump unit	UTZ-PX1NBA	—	—	○	—
External connect kit	UTY-XWZXZG	○	○	○	—
	UTY-XWZXZ3	—	—	—	○

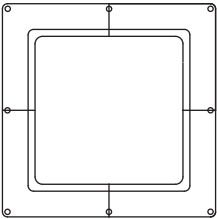
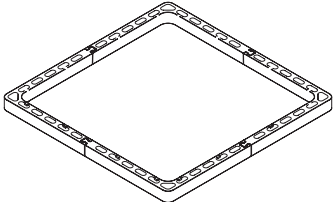
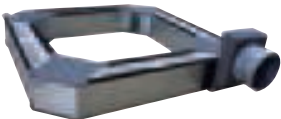
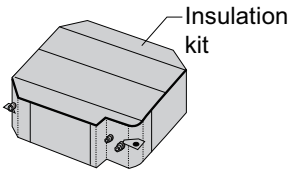
Parts (for Indoor unit)

Exterior	Part name	Model name	Summary
	Remote sensor unit	UTY-XSZX	Thermo-sensor for sensing the temperature of arbitrary place in the room.
	Auto louver grille kit	UTD-GXSB-W	Width: 883 mm
	Square flange	UTD-SF045T	Both the Square flange and the Round flange can be selected.
	Round flange	UTD-RF204	Round flange is used when the fresh-air duct is installed.
	Long-life filter	UTD-LF25NA	Long-life filter can be mounted to the indoor unit.

Exterior	Part name	Model name	Summary
	Drain pump unit	UTZ-PX1NBA	Optional drain lift up mechanism allows more flexible installation.
	External connect kit	UTY-XWZXZG	Use to connect with various peripheral devices and air conditioner PCB. For control output port.
	Air outlet shutter plate	UTR-YDZC	Installed at the air outlet when 3-directions mode is performed.
	Wide panel	UTG-AKXA-W	Hides the gap between the ceiling hole and the cassette grille.
	Panel spacer	UTG-BGYA-W	If there is not enough height in the ceiling space, by inserting this spacer between the cassette grille and the ceiling surface, the height of the unit body goes into the ceiling space become 50-mm lower.
	Fresh-air intake kit	UTZ-VXAA	By attaching Fresh-air intake kit to the indoor unit, it can be taken in fresh air of up to 10% of "high" air volume of the indoor unit.
	Insulation for high humidity	UTZ-KXGA	Install when the under-roof condition is expected to be the humidity of over 80% and the temperature of over 30 °C.
	Wireless LAN adapter	UTY-TFSXZ1	Remotely manage an air conditioning system using mobile devices such as smartphones and tablets. For connection indoor unit with UART interface.
	Modbus converter	UTY-VMSX	For connection between indoor unit with UART interface and a Modbus open network.
	KNX converter	UTY-VKSX	For connection between indoor unit with UART interface and a KNX open network.

Exterior	Part name	Model name	Summary
	External switch controller	UTY-TERX	Air conditioner switching can be controlled by connecting other external sensor switches.

NOTE: Combined use of following optional parts and Wireless LAN adapter (UTY-TFSXZ1) is not allowed.

- Modbus converter
- KNX converter

■ Parts (for Outdoor unit)

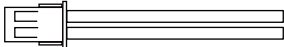
Exterior	Part name	Model name	Summary
	External connect kit	UTY-XWZXZ3	Use to operate the external input and output functions of outdoor unit.





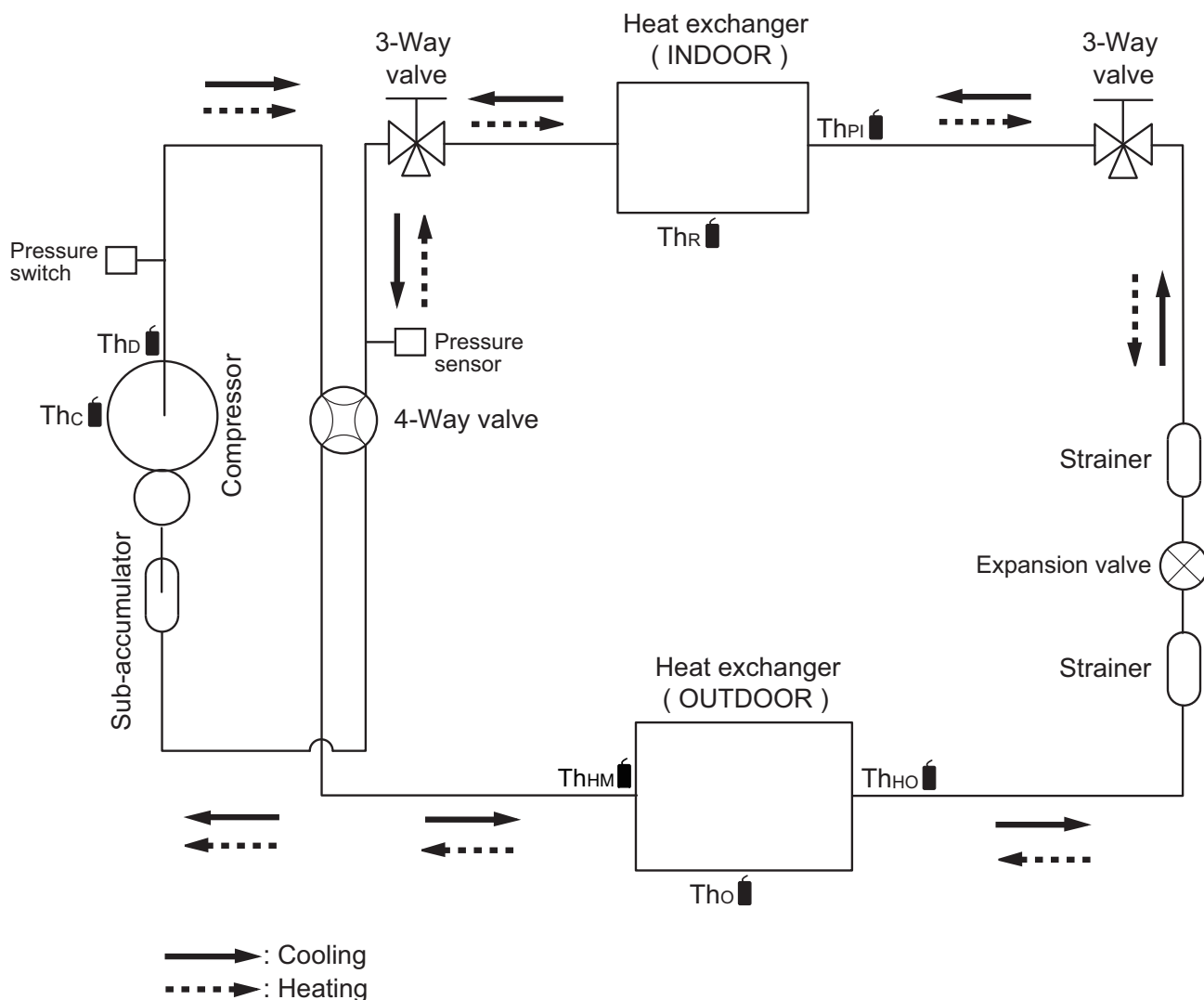

7. Refrigerant system diagrams

7-1. Models: AOYG36KRTA, AOYG45KRTA, and AOYG54KRTA

TECHNICAL DATA
AND PARTS LIST

TECHNICAL DATA
AND PARTS LIST



- Thc  : Thermistor (Compressor temperature)
- ThD  : Thermistor (Discharge temperature)
- ThHM  : Thermistor (Heat Exchanger Med temperature)
- Tho  : Thermistor (Outdoor temperature)
- ThHO  : Thermistor (Heat Exchanger Out temperature)
- ThR  : Thermistor (Room temperature)
- ThPI  : Thermistor (Pipe temperature)

8. Wiring diagrams

8-1. Indoor unit

■ Compact cassette type

● Models: AUXG18KVLA, AUXG22KVLA, and AUXG24KVLA

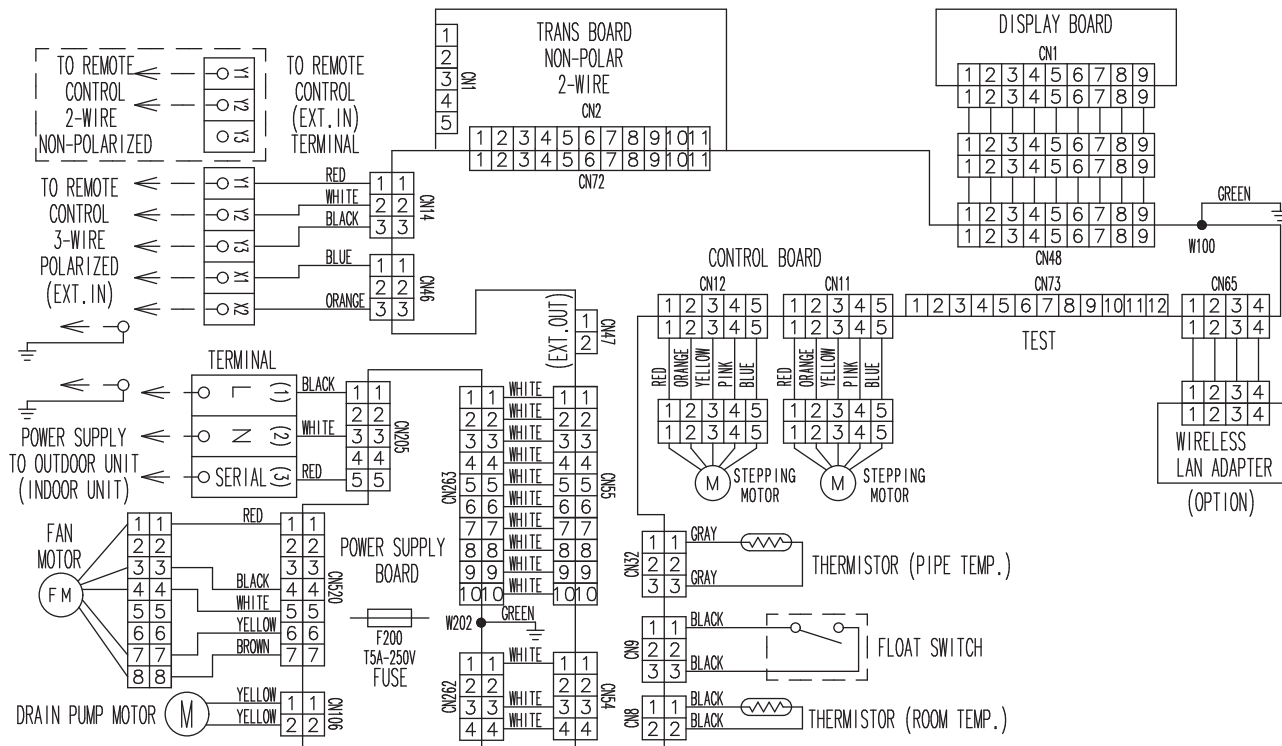

■ Slim duct type

● Model: ARXG18KLLAP

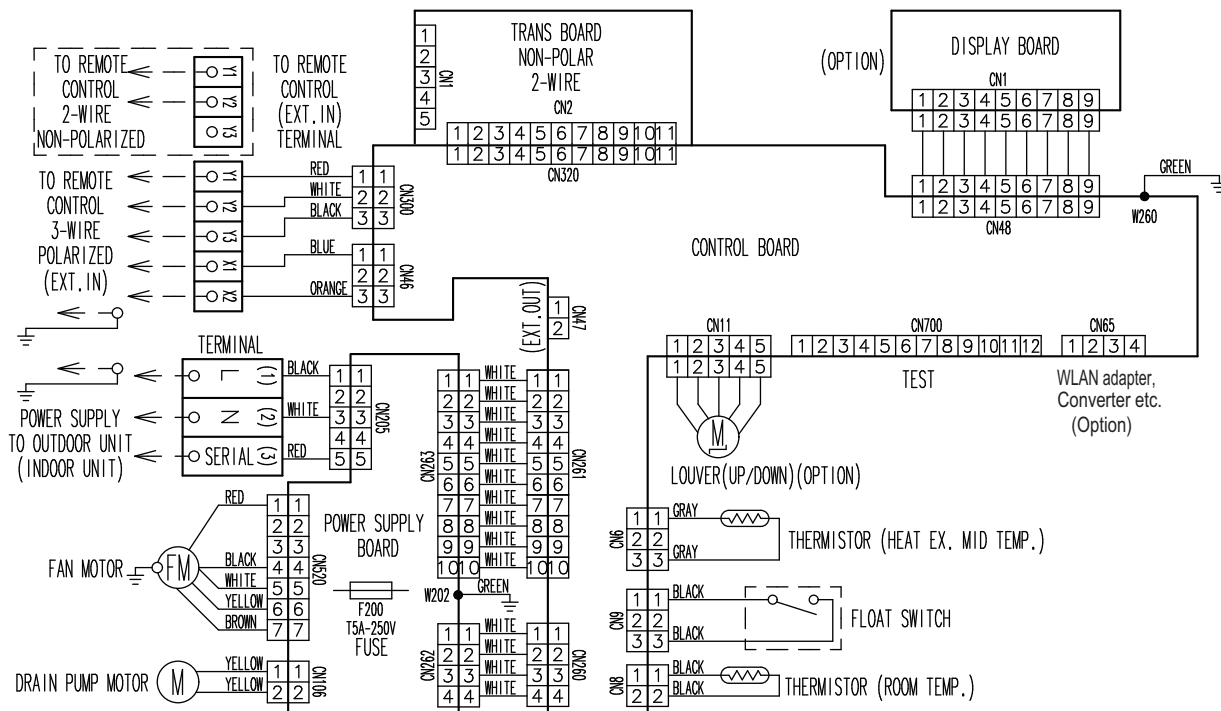

Duct type

Models: ARXG22KMLA and ARXG24KMLA

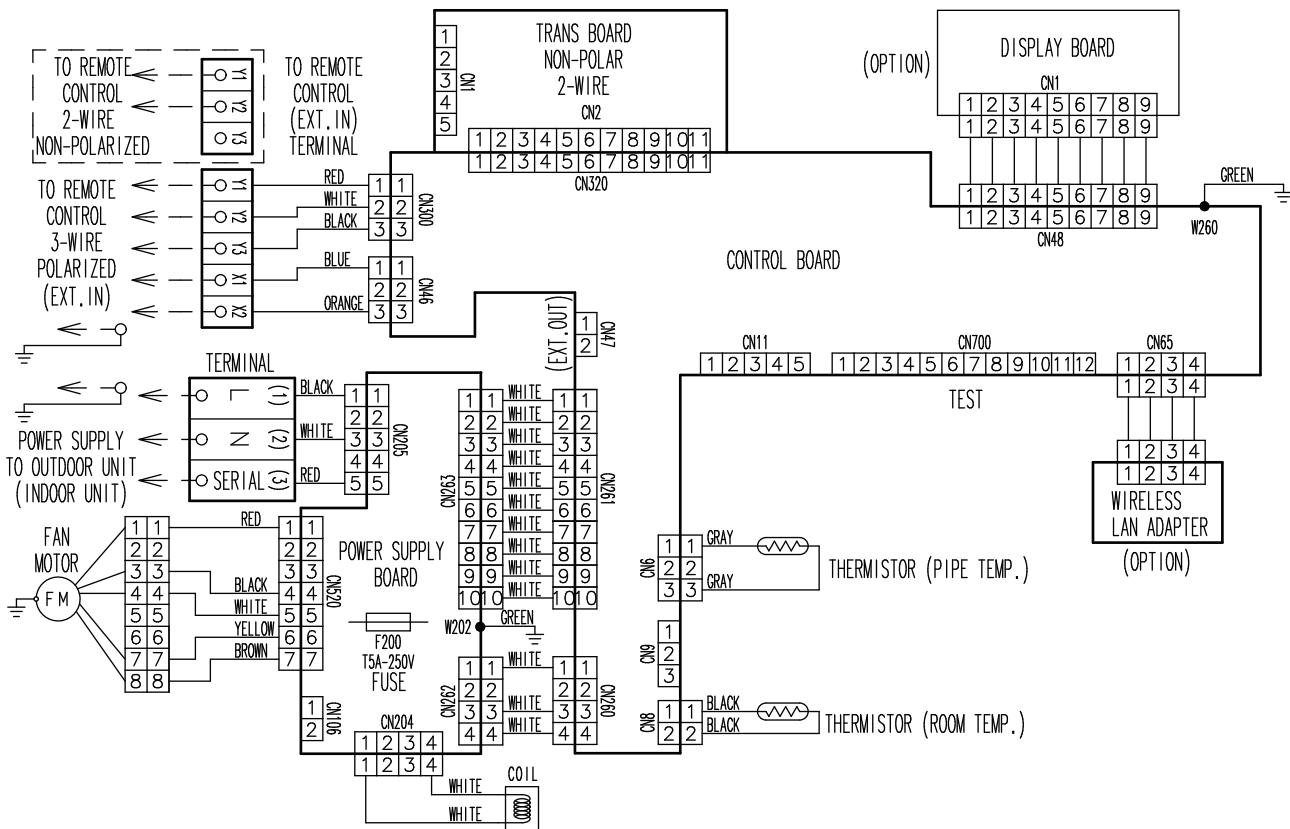

8-2. Outdoor unit

Model: AOYG36KRTA

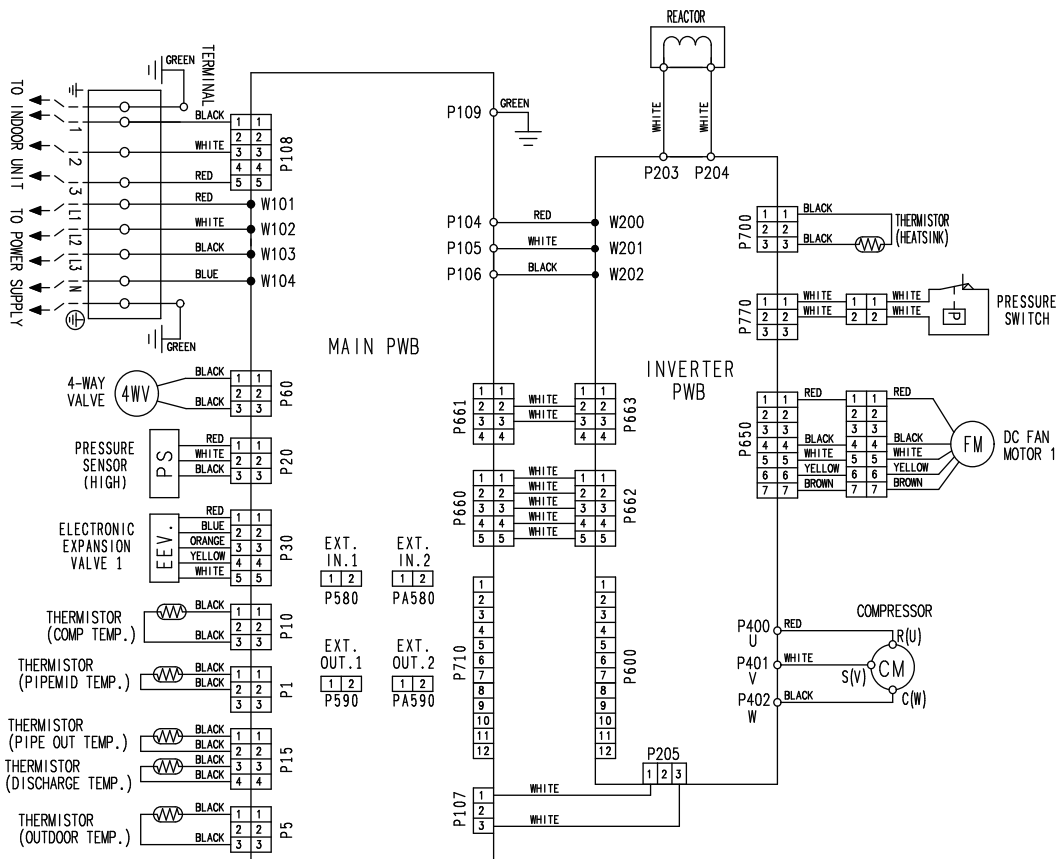

Models: AOYG45KRTA and AOYG54KRTA

TECHNICAL DATA
AND PARTS LIST

TECHNICAL DATA
AND PARTS LIST

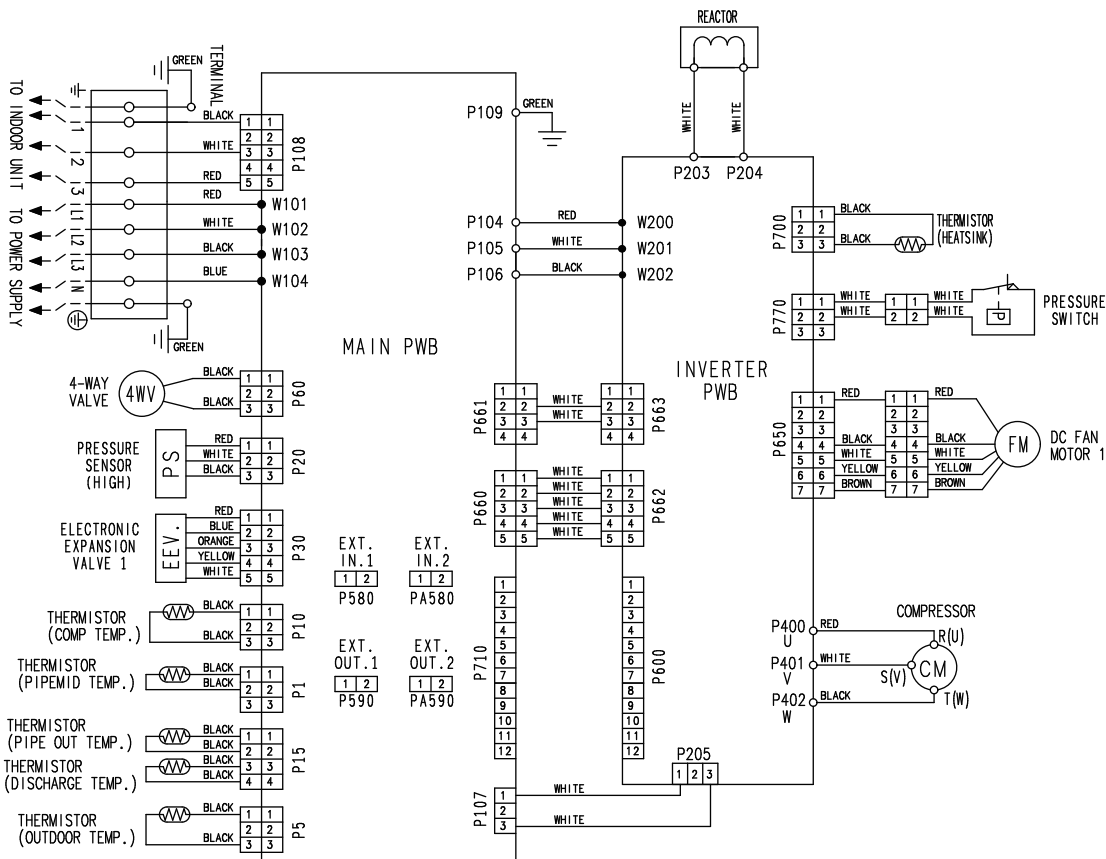

9-2. Model: ARXG18KLLAP

CONTROL UNIT

09 model: EZ-0181YHSE 14 model: EZ-01814HSE
 12 model: EZ-01820HSE 18 model: EZ-01813HSE

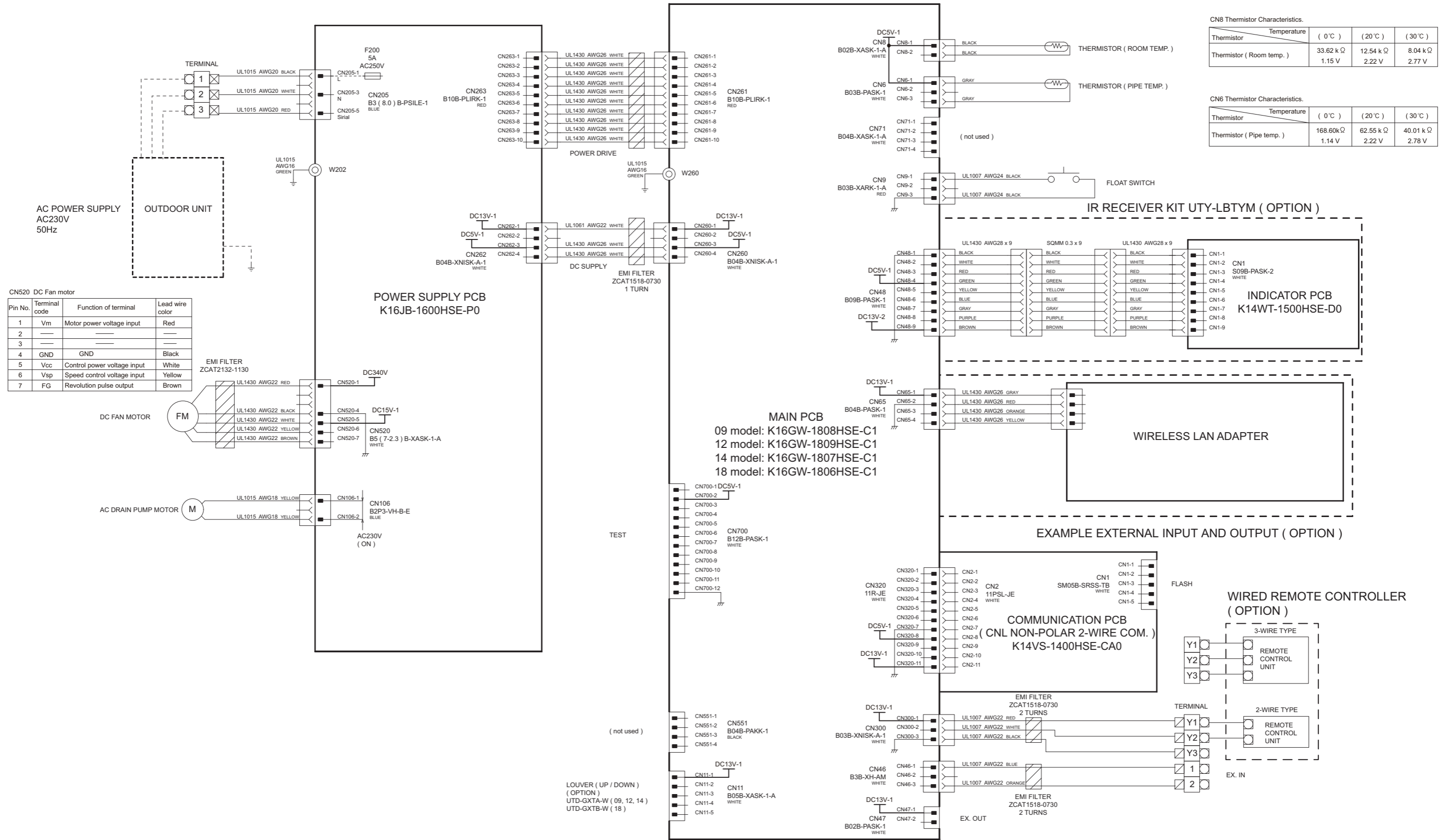

CN8 Thermistor Characteristics.

Thermistor	Temperature	(0 °C)	(20 °C)	(30 °C)
Thermistor (Room temp.)		33.62 k Ω	12.54 k Ω	8.04 k Ω
		1.15 V	2.22 V	2.77 V

CN6 Thermistor Characteristics.

Thermistor	Temperature	(0 °C)	(20 °C)	(30 °C)
Thermistor (Pipe temp.)		168.60k Ω	62.55 k Ω	40.01 k Ω
		1.14 V	2.22 V	2.78 V

CN520 DC Fan motor

Pin No.	Terminal code	Function of terminal	Lead wire color
1	Vm	Motor power voltage input	Red
2	---	---	---
3	---	---	---
4	GND	GND	Black
5	Vcc	Control power voltage input	White
6	Vsp	Speed control voltage input	Yellow
7	FG	Revolution pulse output	Brown

TECHNICAL DATA AND PARTS LIST

TECHNICAL DATA AND PARTS LIST

9-3. Models: ARXG22KMLA and ARXG24KMLA

TECHNICAL DATA AND PARTS LIST

TECHNICAL DATA AND PARTS LIST

CONTROL UNIT
22 model: EZ-01811HSE
24 model: EZ-0182EHSE

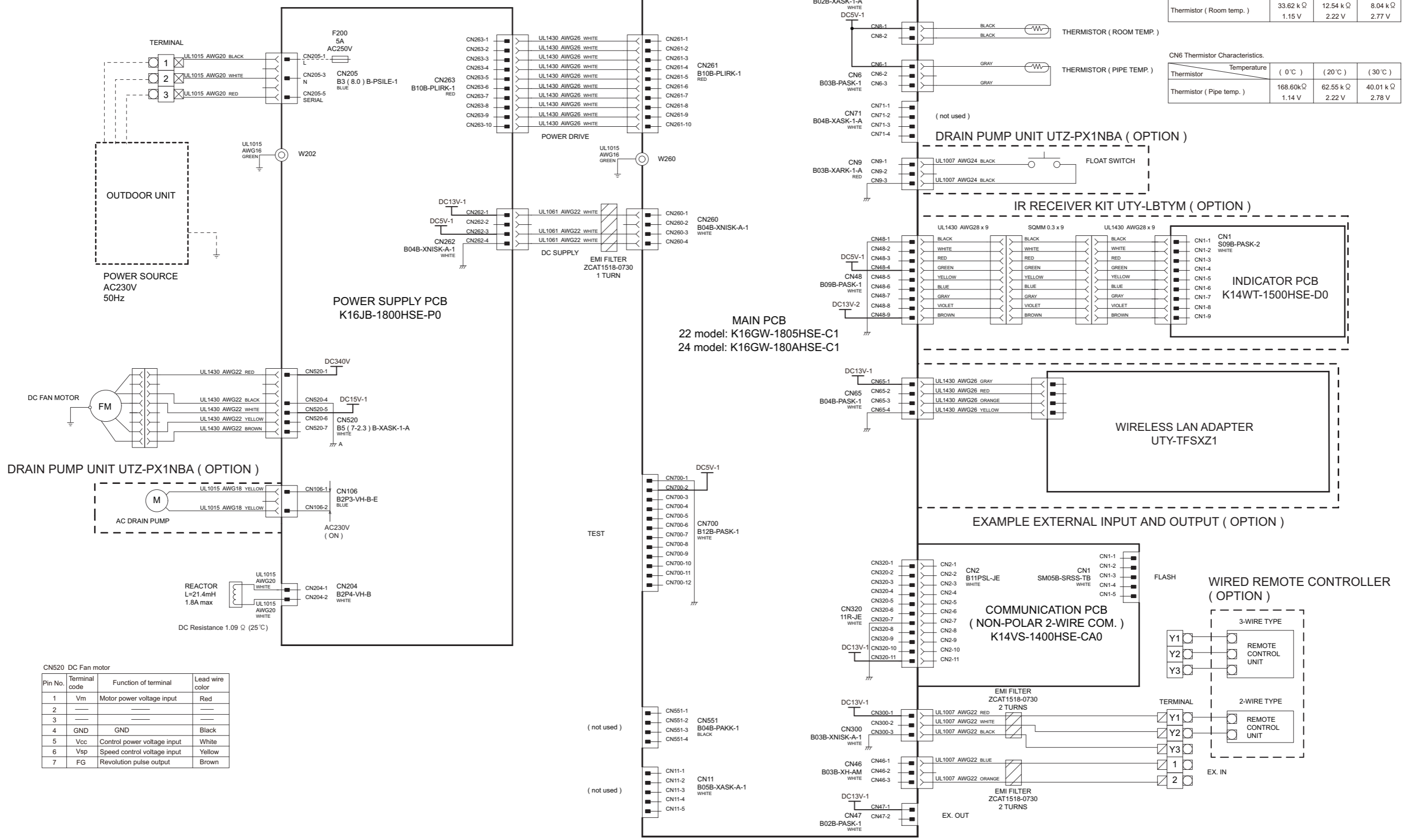

CN8 Thermistor Characteristics.

Thermistor	Temperature	(0 °C)	(20 °C)	(30 °C)
Thermistor (Room temp.)		33.62 k Ω	12.54 k Ω	8.04 k Ω
		1.15 V	2.22 V	2.77 V

CN6 Thermistor Characteristics.

Thermistor	Temperature	(0 °C)	(20 °C)	(30 °C)
Thermistor (Pipe temp.)		168.60k Ω	62.55 k Ω	40.01 k Ω
		1.14 V	2.22 V	2.78 V

CN520 DC Fan motor

Pin No.	Terminal code	Function of terminal	Lead wire color
1	Vm	Motor power voltage input	Red
2	—	—	—
3	—	—	—
4	GND	GND	Black
5	Vcc	Control power voltage input	White
6	Vsp	Speed control voltage input	Yellow
7	FG	Revolution pulse output	Brown

9-4. Models: AOYG36KRTA, AOYG45KRTA, and AOYG54KRTA

TECHNICAL DATA AND PARTS LIST

TECHNICAL DATA AND PARTS LIST

INVERTER ASSEMBLY
 36 model: EZ-0190HUE
 45 model: EZ-0191HUE
 54 model: EZ-0191HUE

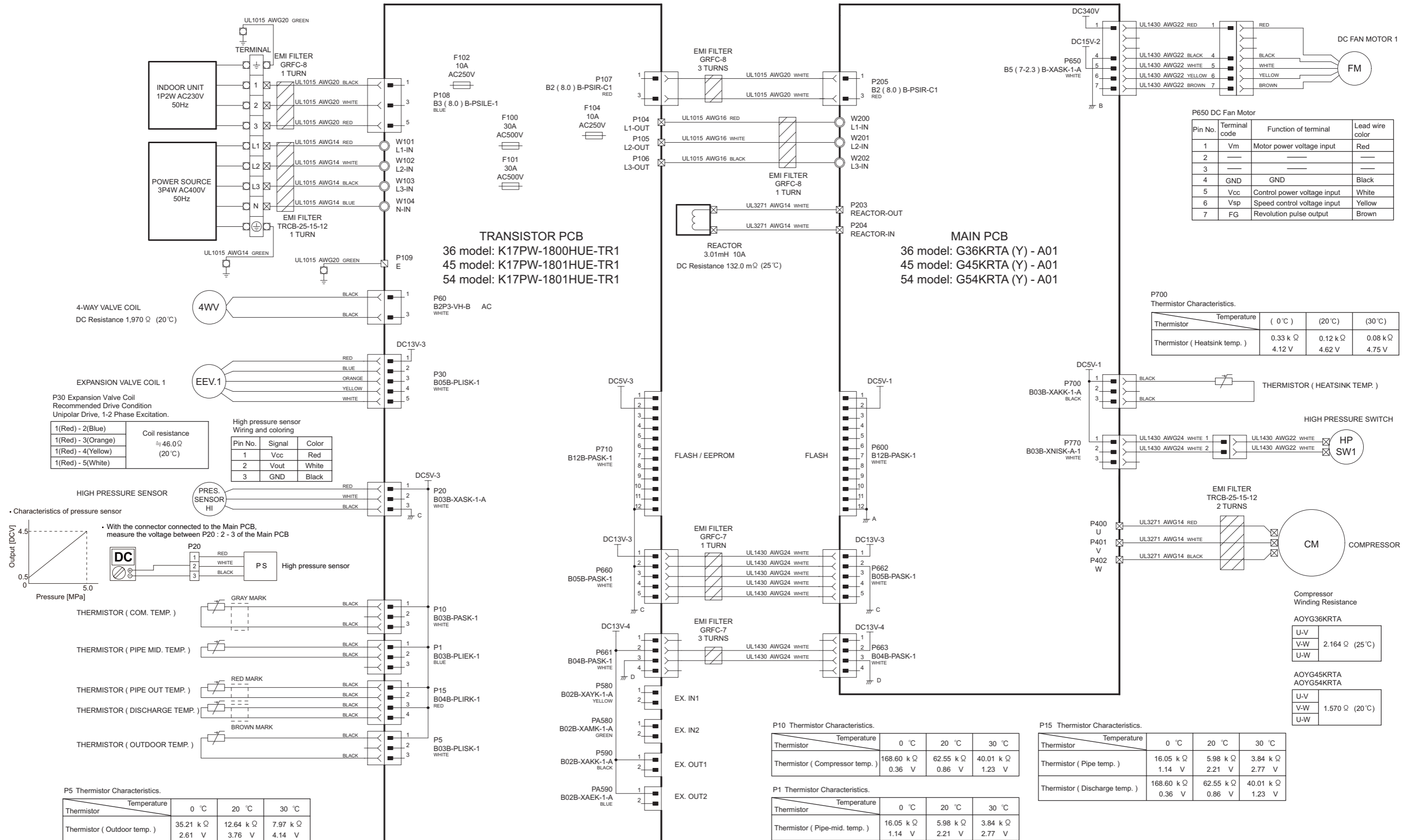

3. TROUBLESHOOTING

CONTENTS

3. TROUBLESHOOTING

1. Error code	03-1
1-1. Error code table (Wired remote controller).....	03-1
1-2. Error code table (Outdoor unit: for 36/45/54 model only).....	03-2
2. Troubleshooting with error code	03-4
2-1. E: 11. Serial communication error (Serial reverse transfer error) (Outdoor unit).....	03-4
2-2. E: 11. Serial communication error (Serial forward transfer error) (Indoor unit)	03-6
2-3. E: 12. Wired remote controller communication error (Indoor unit)	03-8
2-4. E: 18. External communication error (Indoor unit)	03-10
2-5. E: 23. Combination error (Outdoor unit).....	03-11
2-6. E: 26. Address setting error in wired remote controller (Indoor unit).....	03-12
2-7. E: 29. Connected unit number error (Indoor unit)	03-13
2-8. E: 32. Indoor unit main PCB error (Indoor unit)	03-14
2-9. E: 33. Indoor unit motor electricity consumption detection error (Indoor unit).....	03-15
2-10. E: 35. MANUAL AUTO button error (Indoor unit).....	03-16
2-11. E: 39. Indoor unit power supply error for fan motor (Indoor unit)	03-17
2-12. E: 3A. Indoor unit communication circuit (wired remote controller) error	03-18
2-13. E: 41. Room temperature sensor error (Indoor unit).....	03-19
2-14. E: 42. Indoor unit heat exchanger sensor error (Indoor unit)	03-20
2-15. E: 51. Indoor unit fan motor error (Indoor unit)	03-21
2-16. E: 53. Drain pump error (Indoor unit).....	03-22
2-17. E: 62. Outdoor unit main PCB error (Outdoor unit).....	03-23
2-18. E: 63. Inverter error (Outdoor unit).....	03-24
2-19. E: 64. PFC circuit error (Outdoor unit)	03-25
2-20. E: 65. Trip terminal L error (Outdoor unit).....	03-26
2-21. E: 71. Discharge thermistor error (Outdoor unit).....	03-27
2-22. E: 72. Compressor thermistor error (Outdoor unit)	03-28
2-23. E: 73. Heat exchanger (Middle/Outlet) temperature thermistor error (Outdoor unit) ...	03-29
2-24. E: 74. Outdoor temperature thermistor error (Outdoor unit).....	03-30
2-25. E: 77. Heat sink thermistor error (Outdoor unit).....	03-31
2-26. E: 84. Current sensor error (Outdoor unit)	03-32
2-27. E: 86. High pressure switch error (Outdoor unit)	03-33
2-28. E: 86. High pressure switch error (Outdoor unit)	03-34
2-29. E: 94. Trip detection (Outdoor unit).....	03-35
2-30. E: 95. Compressor motor control error (Outdoor unit)	03-36
2-31. E: 97. Outdoor unit fan motor error (Outdoor unit).....	03-37
2-32. E: 99. 4-way valve error (Outdoor unit).....	03-39
2-33. E: A1. Discharge temperature error (Outdoor unit).....	03-41
2-34. E: A3. Compressor temperature error (Outdoor unit).....	03-43
2-35. E: A5. Low pressure error (Outdoor unit).....	03-45
2-36. E: AC. Heat sink temperature error (Outdoor unit).....	03-47
3. Troubleshooting without error code.....	03-48
3-1. Indoor unit—No power.....	03-48

CONTENTS (continued)

3-2. Outdoor unit—No power	03-49
3-3. No operation (Power is on)	03-50
3-4. No cooling/No heating	03-52
3-5. Abnormal noise.....	03-54
3-6. Water leaking.....	03-55
4. Service parts information	03-56
4-1. Compressor	03-56
4-2. Inverter compressor.....	03-57
4-3. Outdoor unit Electronic Expansion Valve (EEV)	03-59
4-4. Indoor unit fan motor	03-61
4-5. Outdoor unit fan motor.....	03-62
4-6. Pressure switch	03-63
4-7. 4-way valve coil (solenoid coil)/4-way valve	03-64
5. Thermistor resistance values.....	03-65
5-1. Indoor unit	03-65
5-2. Outdoor unit.....	03-66

1. Error code

1-1. Error code table (Wired remote controller)

The operation, timer, and economy indicators operate according to the error contents.
For confirmation of the error contents, refer the flashing pattern as follows.

Error contents	Wired remote controller display
E: 11. Serial communication error (Serial reverse transfer error) (Outdoor unit)	11
E: 11. Serial communication error (Serial forward transfer error) (Indoor unit)	11
E: 12. Wired remote controller communication error (Indoor unit)	12
E: 18. External communication error (Indoor unit)	18
E: 23. Combination error (Outdoor unit)	23
E: 26. Address setting error in wired remote controller (Indoor unit)	26
E: 29. Connected unit number error (Indoor unit)	29
E: 32. Indoor unit main PCB error (Indoor unit)	32
E: 33. Indoor unit motor electricity consumption detection error (Indoor unit)	33
E: 35. MANUAL AUTO button error (Indoor unit)	35
E: 39. Indoor unit power supply error for fan motor (Indoor unit)	39
E: 3A. Indoor unit communication circuit (wired remote controller) error	3A
E: 41. Room temperature sensor error (Indoor unit)	41
E: 42. Indoor unit heat exchanger sensor error (Indoor unit)	42
E: 51. Indoor unit fan motor error (Indoor unit)	51
E: 53. Drain pump error (Indoor unit)	53
E: 62. Outdoor unit main PCB error (Outdoor unit)	62
E: 63. Inverter error (Outdoor unit)	63
E: 64. PFC circuit error (Outdoor unit)	64
E: 65. Trip terminal L error (Outdoor unit)	65
E: 71. Discharge thermistor error (Outdoor unit)	71
E: 72. Compressor thermistor error (Outdoor unit)	72
E: 73. Heat exchanger (Middle/Outlet) temperature thermistor error (Outdoor unit)	73
E: 74. Outdoor temperature thermistor error (Outdoor unit)	74
E: 77. Heat sink thermistor error (Outdoor unit)	77
E: 84. Current sensor error (Outdoor unit)	84
E: 86. High pressure switch error (Outdoor unit)	86
E: 86. High pressure switch error (Outdoor unit)	86
E: 94. Trip detection (Outdoor unit)	94
E: 95. Compressor motor control error (Outdoor unit)	95
E: 97. Outdoor unit fan motor error (Outdoor unit)	97
E: 99. 4-way valve error (Outdoor unit)	99
E: A1. Discharge temperature error (Outdoor unit)	A1
E: A3. Compressor temperature error (Outdoor unit)	A3
E: A5. Low pressure error (Outdoor unit)	A5
E: AC. Heat sink temperature error (Outdoor unit)	AC

1-2. Error code table (Outdoor unit: for 36/45/54 model only)

The operation status is determined by the lighting up and blinking of the LED lamp.
After check that ERROR LED lamp blinks, press the ENTER button once.

NOTE: For the positions of LED lamp and buttons, refer to "Functionsettings (for outdoor unit)" in Chapter 5. FIELD WORK.

Error contents	POWER/ MODE	ERROR	PUMP DOWN	LOW NOISE		PEAK CUT		
			L1	L2	L3	L4	L5	L6
E: 11. Serial communication error (Serial forward transfer error) (Indoor unit)	■ 2	●	■ 1	■ 1	○	○	●	●
E: 11. Serial communication error (Serial forward transfer error) (Indoor unit)	■ 2	●	■ 1	■ 1	○	●	○	○
E: 12. Wired remote controller communication error (Indoor unit)	■ 2	●	■ 5	■ 15	○	○	○	●
E: 18. External communication error (Indoor unit)	■ 2	●	■ 5	■ 15	○	○	○	●
E: 23. Combination error (Outdoor unit)	■ 2	●	■ 5	■ 15	○	○	○	●
E: 26. Address setting error in wired remote controller (Indoor unit)	■ 2	●	■ 5	■ 15	○	○	○	●
E: 29. Connected unit number error (Indoor unit)	■ 2	●	■ 5	■ 15	○	○	○	●
E: 32. Indoor unit main PCB error (Indoor unit)	■ 2	●	■ 5	■ 15	○	○	○	●
E: 33. Indoor unit motor electricity consumption detection error (Indoor unit)	■ 2	●	■ 5	■ 15	○	○	○	●
E: 39. Indoor unit power supply error for fan motor (Indoor unit)	■ 2	●	■ 5	■ 15	○	○	○	●
E: 3A. Indoor unit communication circuit (wired remote controller) error	■ 2	●	■ 5	■ 15	○	○	○	●
E: 41. Room temperature sensor error (Indoor unit)	■ 2	●	■ 5	■ 15	○	○	○	●
E: 42. Indoor unit heat exchanger sensor error (Indoor unit)	■ 2	●	■ 5	■ 15	○	○	○	●
E: 51. Indoor unit fan motor error (Indoor unit)	■ 2	●	■ 5	■ 15	○	○	○	●
E: 53. Drain pump error (Indoor unit)	■ 2	●	■ 5	■ 15	○	○	○	●
E: 62. Outdoor unit main PCB error (Outdoor unit)	■ 2	●	■ 6	■ 2	○	○	○	●
E: 63. Inverter error (Outdoor unit)	■ 2	●	■ 6	■ 3	○	○	○	●
E: 65. Trip terminal L error (Outdoor unit)	■ 2	●	■ 6	■ 5	○	○	●	●
E: 71. Discharge thermistor error (Outdoor unit)	■ 2	●	■ 7	■ 1	○	○	○	●
E: 72. Compressor thermistor error (Outdoor unit)	■ 2	●	■ 7	■ 2	○	○	○	●
E: 73. Heat exchanger (Middle/Outlet) temperature thermistor error (Outdoor unit)	■ 2	●	■ 7	■ 3	○	○	●	○
E: 74. Outdoor temperature thermistor error (Outdoor unit)	■ 2	●	■ 7	■ 4	○	○	○	●
E: 77. Heat sink thermistor error (Outdoor unit)	■ 2	●	■ 7	■ 7	○	○	○	●

Error contents	POWER/ MODE	ERROR	PUMP DOWN	LOW NOISE		PEAK CUT		
			L1	L2	L3	L4	L5	L6
E: 84. Current sensor error (Outdoor unit)	■ 2	●	■ 8	■ 4	○	○	○	●
E: 86. High pressure switch error (Outdoor unit)	■ 2	●	■ 8	■ 6	○	●	○	○
E: 86. High pressure switch error (Outdoor unit)	■ 2	●	■ 8	■ 6	○	●	●	○
E: 94. Trip detection (Outdoor unit)	■ 2	●	■ 9	■ 4	○	○	○	●
E: 95. Compressor motor control error (Outdoor unit)	■ 2	●	■ 9	■ 5	○	○	○	●
E: 97. Outdoor unit fan motor error (Outdoor unit)	■ 2	●	■ 9	■ 7	○	○	●	●
E: 99. 4-way valve error (Outdoor unit)	■ 2	●	■ 9	■ 9	○	○	○	●
E: A1. Discharge temperature error (Outdoor unit)	■ 2	●	■ 10	■ 1	○	○	○	●
E: A3. Compressor temperature error (Outdoor unit)	■ 2	●	■ 10	■ 3	○	○	○	●
E: A5. Low pressure error (Outdoor unit)	■ 2	●	■ 10	■ 5	○	○	○	●
E: AC. Heat sink temperature error (Outdoor unit)	■ 2	●	■ 10	■ 12	○	○	●	●

● : Light on ○ : Light off ■ (n) : n Times blinking

2. Troubleshooting with error code

2-1. E: 11. Serial communication error (Serial reverse transfer error) (Outdoor unit)

Indicator	Wired remote controller	Error code	E: 11
Detective actuator	Outdoor unit	Main PCB	When the indoor unit cannot receive the serial signal from outdoor unit more than 2 minutes after power on, or the indoor unit cannot receive the serial signal more than 15 seconds during normal operation.
		Fan motor	
Forecast of cause			Connection failure
			External cause
			Main PCB failure
			Outdoor unit fan motor failure

Check point 1. Reset the power and operate

Does error indication show again?

→ If no, go to "Check point 1-2".



Check point 2. Check connection

Check any loose or removed connection line of indoor unit and outdoor unit.

Check connection condition is control unit. (If there is loose connector, open cable or mis-wiring.)

→ If there is an abnormal condition, correct it by referring to the installation manual or the "DESIGN & TECHNICAL MANUAL".



Check point 3. Check the voltage of power supply

Check the voltage of power supply

Check if AC 198 V (AC 220 V -10%) to AC 264 V (AC 240 V +10%) appears at outdoor unit terminal L — N.



Check point 4. Check serial signal (Reverse transfer signal)

Check serial signal (Reverse transfer signal)

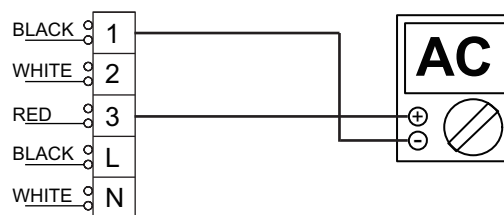

- Check if indicated value swings between AC 90 V and AC 270 V at the outdoor unit terminal 1—3.
- If it is abnormal, check the parts below.
 - Outdoor unit fan motor in "[Service parts information](#)" on page 03-56
- If outdoor fan motor is abnormal, replace outdoor unit fan motor and main PCB.
- If the checked parts are normal, replace the main PCB.



End

Check point 1-2. Check external cause such as noise

- Check the complete insulation of the grounding.
- Check if there is any equipment that causes harmonic wave near the power cable (Neon light bulb or any electronic equipment which causes harmonic wave).



End

2-2. E: 11. Serial communication error (Serial forward transfer error) (Indoor unit)

Indicator	Wired remote controller	Error code	E: 11
Detective actuator	Indoor unit	Main PCB	When the outdoor unit cannot receive the serial signal from indoor unit more than 10 seconds.
Forecast of cause			Connection failure
			External cause
			Main PCB failure

Check point 1. Reset the power and operate

Does error indication show again?

→ If no, go to "Check point 1-2".



Check point 2. Check connection

Check any loose or removed connection line of indoor unit and outdoor unit.

Check connection condition is control unit. (If there is loose connector, open cable or mis-wiring.)

→ If there is an abnormal condition, correct it by referring to the installation manual or the "DESIGN & TECHNICAL MANUAL".



Check point 3. Check the voltage of power supply

Check the voltage of power supply

Check if AC 198 V (AC 220 V -10%) to AC 264 V (AC 240 V +10%) appears at outdoor unit terminal L — N.



Check point 4. Check serial signal (Forward transfer signal)

Check serial signal (Forward transfer signal)

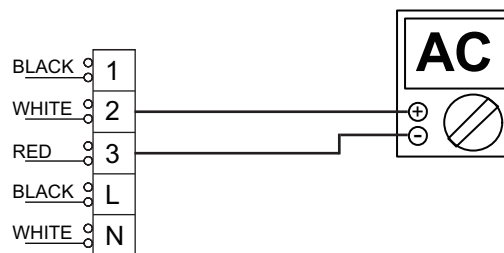

- Check if indicated value swings between AC 30 V and AC 130 V at outdoor unit terminal 2—3.
- If it is abnormal, replace main PCB.



End

Check point 1-2. Check external cause such as noise

- Check the complete insulation of the grounding.
- Check if there is any equipment that causes harmonic wave near the power cable (Neon light bulb or any electronic equipment which causes harmonic wave).



End

2-3. E: 12. Wired remote controller communication error (Indoor unit)

Indicator	Wired remote controller	Error code	E: 12
Detective actuator	Indoor unit	Main PCB	When the indoor unit cannot receive the signal from wired remote controller more than following time during normal operation. <ul style="list-style-type: none"> • 3-wire type: 1 minute • 2-wire type: 2.5 minutes
	Wired remote control		
Forecast of cause			Terminal connection abnormal
			Wired remote control failure
			Main PCB failure

Check point 1. Check the connection of terminal

After turning off the power, check & correct the followings.

- Check the connection of terminal between wired remote controller and indoor unit, and check if there is a disconnection of the cable.



Check Point 1-2 : Check Wired remote controller and main PCB

[AU type]

Check voltage at CN14 of main PCB (terminal 1—3, terminal 1—2). (Power supply to the remote controller)

- If it is DC 12 V, remote controller is failure. (Main PCB is normal)
 - Replace remote control
- If it is DC 0 V, main PCB is failure. (Check remote controller once again)
 - Replace main PCB

[AR type]

Check voltage at CN300 of main PCB (terminal 1—3, terminal 1—2). (Power supply to the remote controller)

- If it is DC 13 V, remote controller is failure. (Main PCB is normal)
 - Replace remote control
- If it is DC 0 V, main PCB is failure. (Check remote controller once again)
 - Replace main PCB



End

Check Point 2 : Wire installation wrong remote controller group setting

- Wrong wire connection in remote controller group (Please refer to the installation manual)
- The number of connecting indoor unit and remote controller in one remote controller group were less than 16 units.

**Check Point 2-1 : Check Indoor unit main PCB**

- Check if main PCB damage
- Change main PCB and check the error after setting remote controller address



End

2-4. E: 18. External communication error (Indoor unit)

Indicator	Wired remote controller	Error code	E: 18
Detective actuator	Indoor unit	External communication error	After receiving a signal from the external input and output PCB, the same signal has not been received for 15 seconds.
Forecast of cause			Connection failure
			External input and output PCB failure
			Main PCB

Check point 1. Check the connection

- Check any loose or removed connection between the main PCB to the external input and output PCB.
-> If there is an abnormal condition, correct it by refer to the installation manual or the "DESIGN & TECHNICAL MANUAL".
- Check the connection condition on the external input and output PCB and the main PCB (If there is loose connector, open cable or mis-wiring.)



Check point 2. Replace the external input and output PCB

If check point 1 do not improve the symptom, change external input and output PCB



Check point 3. Replace main PCB

If check point 2 do not improve the symptom, change main PCB



End

2-5. E: 23. Combination error (Outdoor unit)

Indicator	Wired remote controller	Error code	E: 23
Detective actuator	Indoor unit		• When the outdoor unit type is multi type
Forecast of cause			Incorrect indoor unit is selected.

Check point 1. Check the type of indoor unit

- Check the type of the connected indoor unit.
-> If there is an abnormal condition, correct it by refer to the installation manual or the "DESIGN & TECHNICAL MANAL".



Check point 2. Replace main PCB

If check point 1 do not improve the symptom, replace main PCB of the outdoor unit.



End

2-6. E: 26. Address setting error in wired remote controller (Indoor unit)

Indicator	Wired remote controller	Error code	E: 26
Detective actuator	Wired remote controller (2-wire)	Indoor unit controller PCB	<ul style="list-style-type: none"> When the address number set by auto setting and manual setting are mixed in one remote controller group When the duplicated address number exists in one remote controller group
Forecast of cause			Wrong wiring of remote controller group
			Wrong remote controller address setting
			Indoor unit main PCB failure
			Remote controller failure

Check point 1. Wire installation

- Check the wire connection in the remote controller group (For installation method, refer to installation manual)
-> If there is an abnormal condition, correct it by refer to the installation manual or the "DESIGN & TECHNICAL MANUAL".



Check point 2. Wrong remote controller group setting

- The given address number by auto setting (00) and the manual set number (except 00) are not existing in one remote controller group.
- The remote controller address setting by UI is not existing same address.
- The duplicate address number is not existing in one remote controller group.



Check point 3. Check indoor unit main PCB

- Check if main PCB is damaged.
- Change main PCB and check the error after setting remote controller address.



End

2-7. E: 29. Connected unit number error (Indoor unit)

Indicator	Wired remote controller	Error code	E: 29
Detective actuator	Wired remote controller (2-wire)	When the number of the connected indoor unit exceeds the limitation.	
	Indoor unit main PCB		
Forecast of cause		Wrong wiring of indoor unit or remote controller	
		Number of indoor unit or remote controller in remote controller group	
		Indoor unit main PCB failure	

Check point 1. Wire installation

- Wrong number of connected indoor unit
-> If there is an abnormal condition, correct it by refer to the installation manual or the "DESIGN & TECHNICAL MANUAL".



Check point 2. Check indoor unit main PCB

- Check if main PCB is damaged.
- Change main PCB and check the error after setting remote controller address.



End

2-8. E: 32. Indoor unit main PCB error (Indoor unit)

Indicator	Wired remote controller	Error code	E: 32
Detective actuator	Indoor unit	main PCB	When power is on and there is some below case. 1. When model information of EEPROM is incorrect. 2. When the access to EEPROM failed.
Forecast of cause			External cause
			Defective connection of electric components
			Main PCB failure

Check point 1. Reset power supply and operate

Does error indication show again?

→ If no, go to "Check point 1-2".



Check point 2. Check Indoor unit electric components

- Check all connectors. (loose connector or incorrect wiring)
- Check any shortage or corrosion on PCB.



Check point 3. Replace main PCB

Change main PCB.



End

Check point 1-2. Check external cause such as noise

- Check if the ground connection is proper.
- Check if there is any equipment that causes harmonic wave near the power cable (Neon light bulb or any electronic equipment which causes harmonic wave).



End

NOTE: EEPROM

EEPROM (Electrically Erasable and Programmable Read Only Memory) is a non-volatile memory which keeps memorized information even if the power is turned off. It can change the contents electronically. To change the contents, it uses higher voltage than normal, and it cannot change a partial contents. (Rewriting shall be done upon erasing the all contents.) There is a limit in a number of rewriting.

2-9. E: 33. Indoor unit motor electricity consumption detection error (Indoor unit)

Indicator	Wired remote controller	Error code	E: 33
Detective actuator	Indoor unit motor electricity consumption detection		When the voltage value or the current value of the motor go beyond the limits
Forecast of cause			Fan motor failure
			Main PCB failure

Check point 1. Check the rotation of fan

Rotate the fan by hand when the operation is off. (Check if fan is caught, drop off or locked motor)
→ If fan or bearing is abnormal, replace it.



Check point 2. Check ambient temperature around the motor

Check excessively high temperature around the motor. (If there is any surrounding equipment that causes heat.)
→ Upon the temperature coming down, restart operation.



Check point 3. Check indoor unit fan motor

Check indoor unit fan motor. (Refer to indoor unit fan motor in "[Service parts information](#)" on page 03-56.)
→ If indoor unit fan motor is abnormal, replace it.



Check point 4. Replace main PCB

If check point 1-3 does not improve the symptom, change main PCB.



End

2-10. E: 35. MANUAL AUTO button error (Indoor unit)

Indicator	Wired remote controller	Error code	E: 35
Detective actuator	Indoor unit controller PCB		When the MANUAL AUTO button becomes on for consecutive 60 or more seconds.
	Indicator PCB		
	Manual auto switch		
Forecast of cause			MANUAL AUTO button failure
			Controller PCB and indicator PCB failure

Check point 1. Check the MANUAL AUTO button

- Check if MANUAL AUTO button is kept pressed.
- Check On/Off switching operation by using a meter.



If MANUAL AUTO button is disabled (on/off switching), replace it.



Check point 2. Replace main PCB and indicator PCB

If Check Point 1 does not improve the symptom, change main PCB and indicator PCB.



End

2-11. E: 39. Indoor unit power supply error for fan motor (Indoor unit)

Indicator	Wired remote controller	Error code	E: 39
Detective actuator	Indoor unit main PCB		<ul style="list-style-type: none"> When a momentary power cut off When do not start fan motor
Forecast of cause			External cause
			Connector connection failure
			Main PCB failure

Check point 1. Check external cause at indoor and outdoor (Voltage drop or Noise)

- Instant drop: Check if there is a large load electric apparatus in the same circuit.
- Momentary power failure: Check if there is a defective contact or leak current in the power supply circuit.
- Noise: Check if there is any equipment causing harmonic wave near electric line. (Neon bulb or electric equipment that may cause harmonic wave)
Check the complete insulation of grounding.



Check point 2. Check connection of Connector

- Check if connector is removed.
- Check erroneous connection.
- Check if cable is open.

→ Upon correcting the removed connector or mis-wiring, reset the power.



Check point 3. Replace main PCB

If check point 1 to 2 do not improve the symptom, change main PCB.



End

2-12. E: 3A. Indoor unit communication circuit (wired remote controller) error

Indicator	Wired remote controller	Error code	E: 3A
Detective actuator	Wired remote controller (2-wire)	Indoor unit controller PCB circuit	Detect the communication error of microcomputer and communication PCB.
	Indoor unit controller PCB circuit		
Forecast of cause			Communication PCB defective
			Indoor unit main PCB defective

Check point 1. Check the connection of terminal

- After turning off the power supply, check and correct the followings
Indoor unit - Check the connection the communication PCB and the main PCB



Check Point 2 : Replace the communication PCB

If the Check point 1 is ok, replace the communication PCB



Check Point 3 : Replace the main PCB

If condition is doesn't change, replace the main PCB



End

2-13. E: 41. Room temperature sensor error (Indoor unit)

Indicator	Wired remote controller	Error code	E: 41
Detective actuator	Indoor unit main PCB	Room temperature thermistor is open or short is detected always.	
	Room temperature thermistor		
Forecast of cause		Connector failure	
		Thermistor failure	
		Main PCB failure	

Check point 1. Check connection of connector

- Check if connector is loose or removed.
- Check erroneous connection.
- Check if thermistor cable is open

-> Reset power when reinstalling due to removed connector or incorrect wiring.



Check point 2. Remove connector and check thermistor resistance value

- For the room thermistor resistance value, refer to "[Thermistor resistance values](#)" on page 03-65.
- If thermistor is either open or shorted, replace it and reset the power.

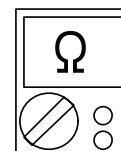

Check point 3. Check voltage of main PCB

Make sure circuit diagram of each indoor unit and check terminal voltage at thermistor (DC 5.0 V).

NOTE: For details of thermistor connector, refer to "[Wiring diagrams](#)" in Chapter 2. TECHNICAL DATA AND PARTS LIST on page 02-37.

If the voltage does not appear, replace main PCB.



End

2-14. E: 42. Indoor unit heat exchanger sensor error (Indoor unit)

Indicator	Wired remote controller	Error code	E: 42
Detective actuator	Indoor unit main PCB	Heat exchanger temperature thermistor	When heat exchanger temperature thermistor open or short circuit is detected.
Forecast of cause			Connector connection failure
			Thermistor failure
			Main PCB failure

Check point 1. Check connection of connector

- Check if connector is loose or removed.
- Check erroneous connection.
- Check if thermistor cable is open

-> Reset power when reinstalling due to removed connector or incorrect wiring.



Check point 2. Remove connector and check thermistor resistance value

- For the heat exchanger thermistor resistance value, refer to "[Thermistor resistance values](#)" on page 03-65.
- If thermistor is either open or shorted, replace it and reset the power.

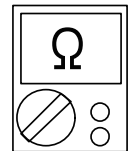

Check point 3. Check voltage of main PCB

Make sure circuit diagram of each indoor unit and check terminal voltage at thermistor (DC 5.0 V).

NOTE: For details of thermistor connector, refer to "[Wiring diagrams](#)" in Chapter 2. TECHNICAL DATA AND PARTS LIST on page 02-37.

If the voltage does not appear, replace main PCB.



End

2-15. E: 51. Indoor unit fan motor error (Indoor unit)

Indicator	Wired remote controller	Error code	E: 51
Detective actuator	Indoor unit	main PCB	When the condition that actual frequency of indoor fan is below 1/3 of target frequency is continued more than 56 seconds.
		Fan motor	
Forecast of cause			Fan rotation failure
			Fan motor winding open
			Motor protection by surrounding temperature rise
			Control PCB failure
			Indoor unit fan motor failure

Check point 1. Check rotation of fan

Rotate the fan by hand when operation is off. (Check if fan is caught, dropped off or locked motor)
→ If fan or bearing is abnormal, replace it.



Check point 2. Check ambient temperature around motor

Check excessively high temperature around the motor. (If there is any surrounding equipment that causes heat)
→ Upon the temperature coming down, restart operation.



Check point 3. Check indoor unit fan motor

Check Indoor unit fan motor. (Refer to indoor unit fan motor in "[Service parts information](#)" on page 03-56.)
→ If Indoor unit fan motor is abnormal, replace Indoor unit fan motor.



Check point 4. Replace main PCB

If Check Point 1 to 3 do not improve the symptom, replace main PCB.



End

2-16. E: 53. Drain pump error (Indoor unit)

Indicator	Wired remote controller	Error code	E: 53
Detective actuator	Indoor unit main PCB Float switch		When Float switch is ON for more than 3 minutes.
Forecast of cause			Float switch failure
			Shorted connector/wire failure
			Main PCB failure
			Drain pump failure
			Hose clogging

Check point 1. Check float switch

- Check operation of float switch. (any blocking by dust, etc.)
- Remove float switch and check ON/OFF switching operation by using a meter.

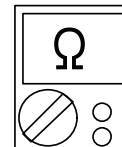

-> If float switch is abnormal, replace it.



Check point 2. Check connector and wire

Check loose contact of CN9 and shorted wire (pinched wire).
-> Replace float switch if the wire is abnormal



Check point 3. Check drain hose

Check drain hose.
-> If there is hose clogging. Please clear the clog.



Check point 4. Replace drain pump

If check point 1 to 3 do not improve the symptom, replace drain pump.



Check point 5. Replace main PCB

If check point 4 do not improve the symptom, replace main PCB.



End

2-17. E: 62. Outdoor unit main PCB error (Outdoor unit)

Indicator	Wired remote controller	Error code	E: 62
Detective actuator	Outdoor unit	Main PCB	Access to EEPROM failed due to some cause after outdoor unit started.
Forecast of cause			External cause (Noise, temporary open, voltage drop) Main PCB failure

Check point 1. Reset power supply and operate

Does error indication show again?

If no, go to "Check point 1-2".



Check point 2. Replace main PCB

Change main PCB.



End

Check point 1-2. Check external cause

- Check if temporary voltage drop was not generated.
- Check if momentary open was not generated.
- Check if ground is connection correctly or there are no related cables near the power line.



End

2-18. E: 63. Inverter error (Outdoor unit)

Indicator	Wired remote controller	Error code	E: 63
Detective actuator	Outdoor unit	Inverter PCB	Error information received from inverter PCB
Forecast of cause			External cause
			Power supply to inverter PCB wiring disconnection or open
			Inverter PCB failure

Check point 1. Turn the power on again?

Error displayed again?

If no, go to "Check point 1-2".



Check point 2. Check the wiring (power supply to inverter PCB)

- Connector and wiring connection state check
- Cable open check



Check point 3. Replace inverter PCB

Replace inverter PCB



End

Check point 1-2. Check external cause

- Check if temporary voltage drop was not generated.
- Check if momentary open was not generated.
- Check if ground is connection correctly or there are no related cables near the power line.



End

2-19. E: 64. PFC circuit error (Outdoor unit)

Indicator	Wired remote controller	Error code	E: 64
Detective actuator	Outdoor unit	Main PCB	<ul style="list-style-type: none"> When inverter input DC voltage is higher than 420 V for over 3 seconds, the compressor stops. If the same operation is repeated 5 times, the compressor stops permanently.
Forecast of cause			External cause
			Connector connection failure
			Main PCB failure

Check point 1. Check external cause at indoor and outdoor (Voltage drop or Noise)

- Instant drop: Check if there is a large load electric apparatus in the same circuit.
- Momentary power failure: Check if there is a defective contact or leak current in the power supply circuit.
- Noise: Check if there is any equipment causing harmonic wave near electric line. (Neon bulb or electric equipment that may cause harmonic wave)
Check the complete insulation of grounding.



Check point 2. Check connection of Connector

- Check if connector is removed.
- Check erroneous connection.
- Check if cable is open.

→ Upon correcting the removed connector or mis-wiring, reset the power.



Check point 3. Replace main PCB

If check point 1 to 2 do not improve the symptom, change main PCB.



End

2-20. E: 65. Trip terminal L error (Outdoor unit)

Indicator	Wired remote controller	Error code	E: 65
Detective actuator	Outdoor unit	Main PCB	When the signal from FO terminal of IPM is "L" (0 V) during the compressor stopping.
Forecast of cause			Main PCB failure

Check point 1. Check main PCB

Replace the outdoor unit main PCB.



End

2-21. E: 71. Discharge thermistor error (Outdoor unit)

Indicator	Wired remote controller	Error code	E: 71
Detective actuator	Outdoor unit main PCB	When discharge pipe temperature thermistor open or short circuit is detected at power on or while running the compressor	
	Discharge pipe temperature thermistor		
Forecast of cause			Connector failure
			Thermistor failure
			Main PCB failure

Check point 1. Check connection of connector

- Check if connector is loose or removed.
- Check erroneous connection.
- Check if thermistor cable is open

→ Reset power when reinstalling due to removed connector or incorrect wiring.



Check point 2. Remove connector and check thermistor resistance value

- For the discharge temperature thermistor resistance value, refer to "[Thermistor resistance values](#)" on page 03-65.
- If thermistor is either open or shorted, replace it and reset the power.

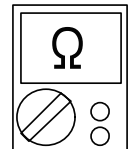

Check point 3. Check voltage of main PCB

Make sure circuit diagram of outdoor unit and check terminal voltage at thermistor (DC 5.0 V).

NOTE: For details of thermistor connector, refer to "[Wiring diagrams](#)" in Chapter 2. TECHNICAL DATA AND PARTS LIST on page 02-37.

If the voltage does not appear, replace main PCB.

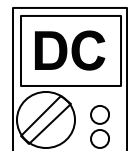

End

2-22. E: 72. Compressor thermistor error (Outdoor unit)

Indicator	Wired remote controller	Error code	E: 72
Detective actuator	Outdoor unit main PCB	When compressor temperature thermistor open or short circuit is detected at power on or while running the compressor	
	Compressor temperature thermistor		
Forecast of cause			Connector failure
			Thermistor failure
			Main PCB failure

Check point 1. Check connection of connector

- Check if connector is loose or removed.
- Check erroneous connection.
- Check if thermistor cable is open

→ Reset power when reinstalling due to removed connector or incorrect wiring.



Check point 2. Remove connector and check thermistor resistance value

- For the compressor thermistor resistance value, refer to "[Thermistor resistance values](#)" on page 03-65.
- If thermistor is either open or shorted, replace it and reset the power.

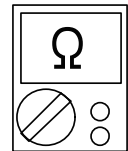

Check point 3. Check voltage of main PCB

Make sure circuit diagram of outdoor unit and check terminal voltage at thermistor (DC 5.0 V).

NOTE: For details of thermistor connector, refer to "[Wiring diagrams](#)" in Chapter 2. TECHNICAL DATA AND PARTS LIST on page 02-37.

If the voltage does not appear, replace main PCB.

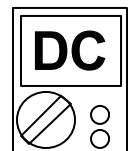

End

2-23. E: 73. Heat exchanger (Middle/Outlet) temperature thermistor error (Outdoor unit)

Indicator	Wired remote controller	Error code	E: 73
Detective actuator	Heat exchanger liquid temperature thermistor		• Heat exchanger liquid temperature thermistor short or open detected
	Heat exchanger middle temperature thermistor		• Heat exchanger middle temperature thermistor short or open detected
Forecast of cause			Connector failure
			Thermistor failure
			Main PCB failure

Check Point 1 : Check the connector connection and cable open

- Connector connection state check
- Cable open check



Check Point 2 : Check the thermistor

- For the outdoor unit heat exchanger thermistor resistance value, refer to "[Thermistor resistance values](#)" on page 03-65.
- If thermistor is either open or shorted, replace it and reset the power.

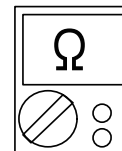

Check point 3. Check voltage of main PCB

Make sure circuit diagram of outdoor unit and check terminal voltage at thermistor (DC 5.0 V).

NOTE: For details of thermistor connector, refer to "[Wiring diagrams](#)" in Chapter 2. TECHNICAL DATA AND PARTS LIST on page 02-37.

If the voltage does not appear, replace main PCB.



End

2-24. E: 74. Outdoor temperature thermistor error (Outdoor unit)

Indicator	Wired remote controller	Error code	E: 74
Detective actuator	Outdoor unit main PCB	When outdoor temperature thermistor open or short circuit is detected at power on or while running the compressor	
	Outdoor temperature thermistor		
Forecast of cause			Connector failure
			Thermistor failure
			Main PCB failure

Check point 1. Check connection of connector

- Check if connector is loose or removed.
- Check erroneous connection.
- Check if thermistor cable is open

-> Reset power when reinstalling due to removed connector or incorrect wiring.



Check point 2. Remove connector and check thermistor resistance value

- For the outdoor temperature thermistor resistance value, refer to "[Thermistor resistance values](#)" on page 03-65.
- If thermistor is either open or shorted, replace it and reset the power.

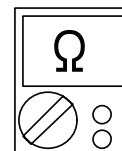

Check point 3. Check voltage of main PCB

Make sure circuit diagram of outdoor unit and check terminal voltage at thermistor (DC 5.0 V).

NOTE: For details of thermistor connector, refer to "[Wiring diagrams](#)" in Chapter 2. TECHNICAL DATA AND PARTS LIST on page 02-37.

If the voltage does not appear, replace main PCB.



End

2-25. E: 77. Heat sink thermistor error (Outdoor unit)

Indicator	Wired remote controller	Error code	E: 77
Detective actuator	Heat sink temperature thermistor	Heat sink temperature thermistor short or open detected	
Forecast of cause			Connector failure
			Thermistor failure
			Inverter PCB failure

Check point 1. Check connection of connector

- Check if connector is loose or removed.
- Check erroneous connection.
- Check if thermistor cable is open

-> Reset power when reinstalling due to removed connector or incorrect wiring.



Check point 2. Remove connector and check thermistor resistance value

- For the outdoor temperature thermistor resistance value, refer to "[Thermistor resistance values](#)" on page 03-65.
- If thermistor is either open or shorted, replace it and reset the power.

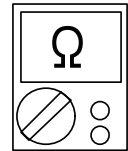

Check point 3. Check voltage of inverter PCB

Make sure circuit diagram of outdoor unit and check terminal voltage at thermistor (DC 5.0 V).

NOTE: For details of thermistor connector, refer to "[Wiring diagrams](#)" in Chapter 2. TECHNICAL DATA AND PARTS LIST on page 02-37.

If the voltage does not appear, replace inverter PCB.

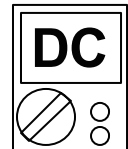

End

2-26. E: 84. Current sensor error (Outdoor unit)

Indicator	Wired remote controller	Error code	E: 84
Detective actuator	Outdoor unit	main PCB	When input current sensor has detected 0 A, while inverter compressor is operating at higher than 50 rps, after 1 minute upon starting the compressor. (Except during the defrost operation)
Forecast of cause			Defective connection of electric components
			External cause
			Main PCB failure

Check point 1. Reset power supply and operate

Does error indication show again?

If no, go to "Check point 1-2".



Check point 2. Check connections of outdoor unit electrical components

- Check if the terminal connection is loose.
- Check if connector is removed.
- Check erroneous connection.
- Check if cable is open.

Upon correcting the removed connector or miswiring, reset the power.



Check point 3. Replace main PCB

If Check point 1, 2 do not improve the symptom, change main PCB.



End

Check point 1-2. Check external cause at Indoor and Outdoor (Voltage drop or Noise)

- Instant drop: Check if there is a large load electric apparatus in the same circuit.
- Momentary power failure: Check if there is a defective contact or leak current in the power supply circuit.
- Noise: Check if there is any equipment causing harmonic wave near electric line. (Neon bulb or electric equipment that may cause harmonic wave)
Check the complete insulation of grounding.



End

2-27. E: 86. High pressure switch error (Outdoor unit)

Indicator	Wired remote controller	Error code	E: 86
Detective actuator	Outdoor unit main PCB	When pressure switch open is detected in 10 seconds after the power is turned on.	
	High pressure switch		
Forecast of cause	High pressure switch connector disconnection or open		
	High pressure switch characteristics failure		
	Main PCB failure		

Check point 1. Check the high pressure switch connection state

- Check connector and wiring connection state.
- Check if cable is open

-> Reset power when reinstalling due to removed connector or incorrect wiring.



Check point 2. Check the high pressure switch characteristics

- Check switch characteristics.
For the characteristics of the high pressure switch, refer to below.



Check point 3. Replace main PCB

Change main PCB and check operation again.



End

- Type of contact

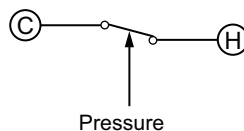

- Characteristics of pressure switch

Pressure switch 1	
Contact: Short → Open	4.2±0.1 MPa
Contact: Open → Short	3.2±0.15 MPa

36/45/54 model: P770

2-28. E: 86. High pressure switch error (Outdoor unit)

Indicator	Wired remote controller	Error code	E: 86
Detective actuator	Outdoor unit main PCB	30 seconds or more after power-on, when pressure sensor detection value detects the condition below continuously for 30 seconds or more. $P_s \leq 0$ or $P_s \geq 5$ [MPa]	
	High pressure switch		
Forecast of cause			Connector connection failure
			Pressure sensor failure
			Main PCB failure

Check point 1. Check connection of the pressure sensor

- Check if the terminal connection is loose.
- Check if connector is removed.
- Check erroneous connection.
- Check if cable is open.

-> Upon correcting the removed connector or mis-wiring, reset the power.



Check point 2. Check output voltage of main PCB

Make sure circuit diagram of outdoor unit and check terminal voltage at thermistor (DC 5.0 V \pm 5%).

NOTE: For details of thermistor connector, refer to "[Wiring diagrams](#)" in Chapter 2. TECHNICAL DATA AND PARTS LIST on page 02-37.

If the voltage is not correct, replace main PCB.



Check point 3. Check output voltage of pressure sensor

Make sure circuit diagram of outdoor unit and check terminal voltage. Voltage is refer to the following graph.

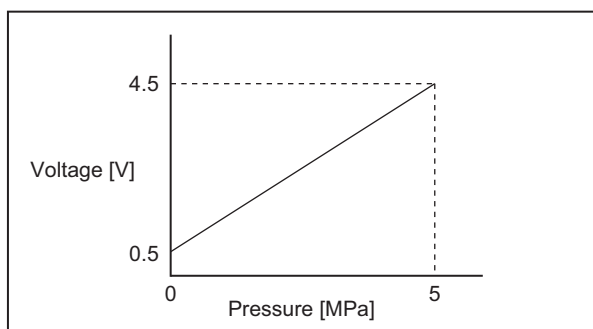

If the voltage is not correct, replace pressure sensor.



End

2-29. E: 94. Trip detection (Outdoor unit)

Indicator	Wired remote controller	Error code	E: 94
Detective actuator	Outdoor unit	Inverter PCB	Protection stop by over-current generation after inverter compressor start processing completed generated consecutively 10 times. NOTE: The number of generations is reset when the compressor starts up.
		Main PCB	
		Compressor	
Forecast of cause			Outdoor unit fan operation defective, foreign matter on heat-exchanger, excessive rise of ambient temperature
			Main PCB failure
			Inverter compressor failure (lock, winding short)
			Inverter PCB

Check point 1. Check the outdoor unit fan operation, heat-exchanger, ambient temperature

- No obstructions in air passages?
- Heat exchange fins clogged
- Outdoor unit fan motor check
- Ambient temperature not raised by the effect of other heat sources?
- Discharged air not sucked in?



Check point 2. Replace inverter PCB

If Check point 1 do not improve the symptom, change inverter PCB.



Check point 3. Replace main PCB

If Check point 1, 2 do not improve the symptom, change main PCB.



Check point 4. Replace compressor

If Check point 3 do not improve the symptom, change compressor.



End

2-30. E: 95. Compressor motor control error (Outdoor unit)

Indicator	Wired remote controller	Error code	E: 95
Detective actuator	Outdoor unit	Main PCB	"Protection stop by "overcurrent generation at inverter compressor starting" restart" generated consecutively 10 times x 3 sets (total 30 times)
		Compressor	
Forecast of cause			Defective connection of electric components
			Main PCB failure
			Compressor failure

Check point 1. Check noise from compressor

Turn on power and check operation noise.
→ If an abnormal noise show, replace compressor.



Check point 2. Check connection of around the compressor components

For compressor terminal, main PCB

- Check if connector is removed.
- Check erroneous connection.
- Check if cable is open. (Refer to inverter compressor in "[Service parts information](#)" on page 03-56.)

→ Upon correcting the removed connector or mis-wiring, reset the power.



Check point 3. Replace main PCB

If Check point 1, 2 do not improve the symptom, change main PCB.



Check point 4. Replace compressor

If Check point 3 do not improve the symptom, change compressor.



End

2-31. E: 97. Outdoor unit fan motor error (Outdoor unit)

Indicator	Wired remote controller	Error code	E: 97
Detective actuator	Outdoor unit	Inverter PCB	<ol style="list-style-type: none"> When outdoor fan rotation speed is less than 100 rpm in 20 seconds after fan motor starts, fan motor stops. After fan motor restarts, if the same operation within 60 seconds is repeated 3 times in a row, compressor and fan motor stops. If 1. and 2. repeats 5 times in a row, compressor and fan motor stops permanently.
		Main PCB	
		Fan motor	
Forecast of cause			Fan rotation failure Motor protection by surrounding temperature rise Inverter PCB failure Main PCB failure Outdoor unit fan motor

Check point 1. Check rotation of fan

Rotate the fan by hand when operation is off. (Check if fan is caught, dropped off or locked motor)
 → If fan or bearing is abnormal, replace it.



Check point 2. Check ambient temperature around motor

Check excessively high temperature around the motor. (If there is any surrounding equipment that causes heat)
 → Upon the temperature coming down, restart operation.



Check point 3. Check outdoor unit fan motor

Check outdoor unit fan motor. (Refer to outdoor unit fan motor in "[Service parts information](#)" on page 03-56.)
 → If outdoor unit fan motor is abnormal, replace outdoor unit fan motor and main PCB.



Check point 4. Check output voltage of inverter PCB

Check outdoor unit circuit diagram and the voltage. (Measure at inverter PCB side connector)

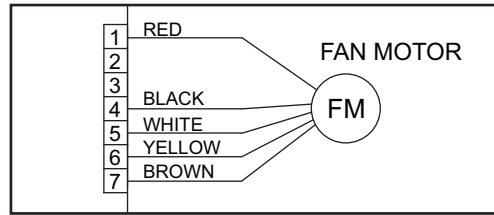

NOTE: For details of wiring diagram, refer to "[Wiring diagrams](#)" in Chapter 2. TECHNICAL DATA AND PARTS LIST on page 02-37.

Read wire	DC voltage
Red—Black	280 V (AC 220 V -10%) to 373 V (AC 240 V +10%)
White—Black	15 ± 1.5 V

-> If the voltage is not correct, replace inverter PCB.



Check point 5. Replace main PCB

If Check point 1 to 4 do not improve the symptom, change main PCB.



End

2-32. E: 99. 4-way valve error (Outdoor unit)

Indicator	Wired remote controller	Error code	E: 99
Detective actuator	Indoor unit	main PCB	When the indoor heat exchanger temperature is compared with the room temperature, and either following condition is detected continuously two times, the compressor stops. Indoor heat exchanger temp. - Room temp. > 10 °C (Cooling or Dry operation) Indoor heat exchanger temp. - Room temp. < -10 °C (Heating operation) If the same operation is repeated 5 times, the compressor stops permanently.
	Heat exchanger temperature thermistor		
	Room temperature thermistor		
	4-way valve		
Forecast of cause			Air filter clogged
			Connector connection failure
			Thermistor failure
			Coil failure
			4-way valve failure
		Main PCB failure	

Check point 1. Check air filter condition

Check air filter dirty.

→ If the air filter dirty, clean up the air filter.



Check point 2. Check connection of connector

- Check if connector is removed.
- Check erroneous connection.
- Check if thermistor cable is open.

→ Upon correcting the removed connector or mis-wiring, reset the power.



Check point 3. Check each thermistor

- Isn't it fallen off the holder?
- Is there a cable pinched?

Check characteristics of room thermistor and indoor unit heat exchanger thermistor.

For the thermistor resistance value, refer to "[Thermistor resistance values](#)" on page 03-65.

→ If defective, replace the thermistor.



Check point 4. Check the solenoid coil and 4-way valve

NOTE: Refer solenoid coil and 4-way valve in "[Service parts information](#)" on page 03-56.

- **Solenoid coil**
Remove P60 from PCB and check the resistance value of coil. Resistance value is 1.97kΩ.
→ If it is open or abnormal resistance value, replace solenoid coil.
- **4-way valve**
Check each piping temperature, and the location of the valve by the temperature difference.
If the value location is not proper, replace 4-way valve.

**Check point 5. Replace main PCB**

If Check Point 1 to 4 do not improve the symptom, replace main PCB.



End

2-33. E: A1. Discharge temperature error (Outdoor unit)

Indicator	Wired remote controller	Error code	E: A1
Detective actuator	Outdoor unit main PCB		Protection stop by discharge temperature ≥ 110 °C during compressor operation generated 2 times within 24 hours.
	Discharge temperature thermistor		
Forecast of cause			3-way valve not opened
			EEV defective, strainer clogged
			Outdoor unit operation failure, foreign matter on heat exchanger
			Discharge temperature thermistor failure
			Insufficient refrigerant
			Main PCB failure

Check point 1. Check if 3-way valve is open

If the 3-way valve is closed, open the 3-way valve and check operation.

NOTE: For cooling operation, check gas side of the 3-way valve.
For heating operation, check liquid side of the 3-way valve.



Check point 2. Check the electronic expansion valve (EEV) and strainer

- Check if EEV open.
Refer to outdoor unit Electronic Expansion Valve (EEV) in "[Service parts information](#)" on page 03-56.
- Check the strainer clogging.



Check point 3. Check the outdoor unit fan and heat exchanger

- Check for foreign object at heat exchanger
- Check if fan can be rotated by hand.
- Check the motor. (Refer to outdoor unit fan motor in "[Service parts information](#)" on page 03-56.)



Check point 4. Check the discharge thermistor

The discharge temperature thermistor characteristics check. (Check by disconnecting thermistor from PCB.)

NOTE: For the characteristics of the thermistor, refer to "[Thermistor resistance values](#)" on page 03-65.



Check point 5. Check the refrigerant amount

Check the refrigerant leakage.



Check point 6. Replace main PCB

If check point 1 to 5 do not improve the symptom, replace the main PCB.



End

2-34. E: A3. Compressor temperature error (Outdoor unit)

Indicator	Wired remote controller	Error code	E: A3
Detective actuator	Outdoor unit main PCB		Protection stop by compressor temperature ≥ 108 °C during compressor operation generated 2 times within 24 hours.
	Compressor temperature thermistor		
Forecast of cause			3-way valve not opened
			EEV defective, strainer clogged
			Outdoor unit operation failure, foreign matter on heat exchanger
			Compressor temperature thermistor failure
			Insufficient refrigerant
			Main PCB failure

Check point 1. Check if 3-way valve is open

If the 3-way valve is closed, open the 3-way valve and check operation.

NOTE: For cooling operation, check gas side of the 3-way valve.
For heating operation, check liquid side of the 3-way valve.



Check point 2. Check the electronic expansion valve (EEV) and strainer

- Check if EEV open.
Refer to outdoor unit Electronic Expansion Valve (EEV) in "[Service parts information](#)" on page 03-56.
- Check the strainer clogging.



Check point 3. Check the outdoor unit fan and heat exchanger

- Check for foreign object at heat exchanger
- Check if fan can be rotated by hand.
- Check the motor. (Refer to outdoor unit fan motor in "[Service parts information](#)" on page 03-56.)



Check point 4. Check the compressor thermistor

The compressor temperature thermistor characteristics check. (Check by disconnecting thermistor from PCB.)

NOTE: For the characteristics of the thermistor, refer to "[Thermistor resistance values](#)" on page 03-65.



Check point 5. Check the refrigerant amount

Check the refrigerant leakage.



Check point 6. Replace main PCB

If check point 1 to 5 do not improve the symptom, replace the main PCB.



End

2-35. E: A5. Low pressure error (Outdoor unit)

Indicator	Wired remote controller	Error code	E: A5
Detective actuator	Outdoor unit main PCB		Protection stop by suction pressure ≥ 0.02 MPaG continued 5 minutes repeats 5 times within 24 hours.
	Suction pressure sensor		
Forecast of cause			3-way valve not opened
			Outdoor unit ambient temperature too low
			Outdoor unit operation failure, foreign matter on heat exchanger
			EEV defective, strainer clogged
			Solenoid valve defective
			Low pressure sensor characteristics defective
			Insufficient refrigerant
			Main PCB failure

Check point 1. Check if 3-way valve is open

If the 3-way valve is closed, open the 3-way valve and check operation.

NOTE: For cooling operation, check gas side of the 3-way valve.

For heating operation, check liquid side of the 3-way valve.



Check point 2. Check the outdoor unit ambient temperature (Only when heating operation)

Outdoor unit ambient temperature lower than operating range?



Check point 3. Check the outdoor unit fan and heat exchanger (Only when heating operation)

- No foreign object in air passage?
- Heat exchanger fins clogged?
- Fan rotates?
- Check the motor. (Refer to outdoor unit fan motor in "[Service parts information](#)" on page 03-56.)



Check point 4. Check the electronic expansion valve (EEV) and strainer

- Check if EEV open.
Refer to outdoor unit Electronic Expansion Valve (EEV) in "[Service parts information](#)" on page 03-56.
- Check the strainer clogging.



Check point 5. Check the suction pressure sensor

Check the suction pressure sensor characteristics.

NOTE: For the characteristics of the thermistor, refer to suction pressure sensor in "[Service parts information](#)" on page 03-56.



Check point 6. Check the refrigerant amount

Check the refrigerant leakage.



Check point 7. Replace main PCB

If check point 1 to 6 do not improve the symptom, replace the main PCB.



End

2-36. E: AC. Heat sink temperature error (Outdoor unit)

Indicator	Wired remote controller	Error code	E: AC
Detective actuator	Outdoor unit inverter PCB		Protection stop by heat sink temperature ≥ 80 °C during heat sink operation generated 2 times within 24 hours.
	Heat sink temperature thermistor		
Forecast of cause			Foreign matter on heat sink, heat sink dirty
			Foreign matter on heat exchanger, excessive ambient temperature rise
			Heat sink temp. thermistor defective

Check point 1. Check the heat sink state

Heat sink foreign matter, soiling check



Check point 2. Check the foreign matter and ambient temperature of heat exchanger

- Heat exchange foreign matter check
- Ambient temperature not raised by effect of other heat sources?
- Discharged air not sucked in?



Check point 3. Check the heat sink temperature thermistor

The heat sink temperature thermistor characteristics check. (Check by disconnecting thermistor from PCB.)

NOTE: For the characteristics of the thermistor, refer to "[Thermistor resistance values](#)" on page 03-65.



Check point 4. Replace inverter PCB

Replace inverter PCB



End

3. Troubleshooting without error code

3-1. Indoor unit—No power

Forecast of cause	Power supply failure
	External cause
	Electrical components defective

Check point 1. Check installation condition

- Isn't the breaker down?
- Check loose or removed connection cable.

-> If abnormal condition is found, correct it by referring to the installation manual or the "DESIGN & TECHNICAL MANUAL".



Check point 2. Check external cause at indoor and outdoor (voltage drop or noise)

- Instant drop: Check if there is a large load electric apparatus in the same circuit.
- Momentary power failure: Check if there is a defective contact or leak current in the power supply circuit.
- Noise: Check if there is any equipment causing harmonic wave near electric line. (Neon bulb or electric equipment that may cause harmonic wave)
Check the complete insulation of grounding.



Check point 3. Check electrical components

Check the voltage of power supply.

Check if AC 198 to 264 V appears at outdoor unit terminal L—N.

-> If no, go to "[Check point 1](#)" and "[Check point 2](#)".

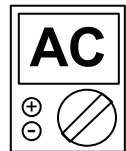

- Check fuse in filter PCB.
If fuse is open, check if the wiring between terminal and filter PCB is loose, and replace fuse.
- Check varistor in filter PCB.
If varistor is defective, there is a possibility of an abnormal power supply.
Check the correct power supply and replace varistor.
Upon checking the normal power supply, replace varistor.



End

3-2. Outdoor unit—No power

Forecast of cause	Power supply failure
	External cause
	Electrical components defective

Check point 1. Check installation condition

- Isn't the breaker down?
- Check loose or removed connection cable.

→ If abnormal condition is found, correct it by referring to the installation manual or the "DESIGN & TECHNICAL MANUAL".



Check point 2. Check external cause at indoor and outdoor (voltage drop or noise)

- Instant drop: Check if there is a large load electric apparatus in the same circuit.
- Momentary power failure: Check if there is a defective contact or leak current in the power supply circuit.
- Noise: Check if there is any equipment causing harmonic wave near electric line. (Neon bulb or electric equipment that may cause harmonic wave)
Check the complete insulation of grounding.



Check point 3. Check electrical components

Check the voltage of power supply.

Check if AC 198 to 264 V appears at outdoor unit terminal L — N

→ If no, go to "[Check point 1](#)" and "[Check point 2](#)".

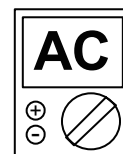

- Check fuse in main PCB.
If fuse is open, check if the wiring between terminal and main PCB is loose, and replace fuse.



Check point 4. Replace main PCB

If check point 1 to 3 do not improve the symptom, change main PCB.



End

3-3. No operation (Power is on)

Forecast of cause	Setting/ Connection failure
	External cause
	Electrical components defective

Check point 1. Check indoor and outdoor installation condition

- Indoor unit:
 - Check incorrect wiring between indoor unit and remote controller.
 - Check if there is an open cable connection.
 - Are these indoor unit, outdoor unit, and remote controller suitable model numbers to connect?
- > If there is some abnormal condition, correct it by referring to the installation manual and “DESIGN & TECHNICAL MANUAL”.



Turn off the power and check correct followings.

- Is there loose or removed communication line of indoor unit and outdoor unit?



Check point 2. Check external cause at indoor and outdoor (Voltage drop or Noise)

- Instant drop: Check if there is a large load electric apparatus in the same circuit.
- Momentary power failure: Check if there is a defective contact or leak current in the power supply circuit.
- Noise: Check if there is any equipment causing harmonic wave near electric line. (Neon bulb or electric equipment that may cause harmonic wave)
Check the complete insulation of grounding.



Check point 3. Check wired remote controller and controller PCB

[AU type]

Check voltage at CN14 of controller PCB. (Terminal 1—3, Terminal 1—2).
(Power supply to remote controller)



- If it is DC 12 V, remote controller is failure. (The controller PCB is normal)
-> Replace remote controller.
- If it is DC 0 V, controller PCB is failure. (Check the remote controller once again)
-> Replace controller PCB.

[AR type]

Check voltage at CN300 of controller PCB. (Terminal 1—3, Terminal 1—2).
(Power supply to remote controller)

- If it is DC 13 V, remote controller is failure. (The controller PCB is normal)
-> Replace remote controller.
- If it is DC 0 V, controller PCB is failure. (Check the remote controller once again)
-> Replace controller PCB.



Check point 4. Replace main PCB

If check point 1 to 3 do not improve the symptom, change main PCB.



End

3-4. No cooling/No heating

Forecast of cause	Indoor unit error
	Outdoor unit error
	Effect by surrounding environment
	Connection pipe/Connection wire failure
	Refrigeration cycle failure

Check point 1. Check Indoor unit

- Does Indoor unit fan run in the HIGH mode?
- Is air filter dirty?
- Is heat exchanger clogged?
- Check if energy save function is operated.



Check point 2. Check outdoor unit operation

- Check if outdoor unit is operating.
- Check any objects that obstruct the air flow route.
- Check if heat exchanger is clogged.
- Is the valve open?



Check point 3. Check site condition

- Is capacity of Indoor unit fitted to the room size?
- Any windows open or direct sunlight?



Check point 4. Check Indoor/ Outdoor installation condition

- Check connection pipe (specified pipe length and pipe diameter?)
- Check any loose or removed communication line.

→ If there is an abnormal condition, correct it by referring to the installation manual or the "DESIGN & TECHNICAL MANUAL".



Check point 5. Check Refrigeration cycle

- Check if strainer is clogged (Refer to the figure below).
- Measure gas pressure, and if there is a leakage, correct it.
- Check the electronic expansion valve.
Refer to outdoor unit Electronic Expansion Valve (EEV) in "[Service parts information](#)" on page 03-56.
- Check compressor.
Refer to compressor in "[Service parts information](#)" on page 03-56.
Refer to inverter compressor in "[Service parts information](#)" on page 03-56.

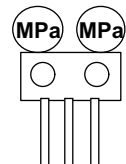

NOTE: When recharging the refrigerant, make sure to perform vacuuming, and recharge the specified amount.



End

NOTES:

- Strainer normally does not have temperature difference between inlet and outlet as shown below.

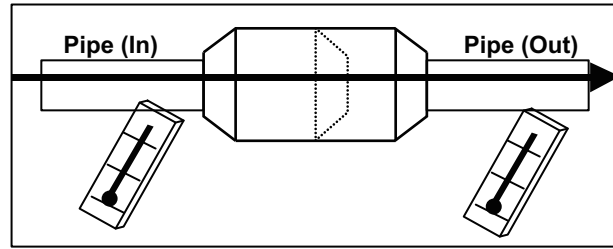

- If there is a difference like shown below, there is a possibility of inside clogged. In this case, replace the strainer.

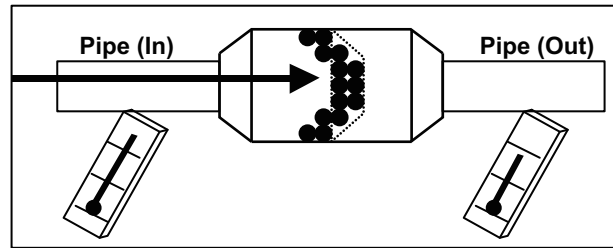

3-5. Abnormal noise

Forecast of cause	Abnormal installation (indoor unit/outdoor unit)
	Fan failure (indoor unit/outdoor unit)
	Compressor failure (outdoor)

Diagnosis method when abnormal noise is occurred

TROUBLESHOOTING

TROUBLESHOOTING

Abnormal noise is coming from Indoor unit.
(Check and correct followings)

Abnormal noise is coming from Indoor unit.
(Check and correct followings)



- Is main unit installed in stable condition?
- Is the installation of air suction grille and front panel normal?

- Is main unit installed in stable condition?
- Is fan guard installed normally?



- Is fan broken or deformed?
- Is the screw of fan loose?
- Is there any object which obstruct the fan rotation?

- Is fan broken or deformed?
- Is the screw of fan loose?
- Is there any object which obstruct the fan rotation?



End

Check if vibration noise by loose bolt or contact noise of piping is happening.



- Is compressor locked?
- Check Compressor
Refer to compressor and inverter compressor in "[Service parts information](#)" on page 03-56.



End

3-6. Water leaking

Forecast of cause	Erroneous installation
	Drain hose failure

Diagnosis method when water leak occurs

- Is main unit installed in stable condition?
- Is main unit broken or deformed at the time of transportation or maintenance?



- Is drain hose connection loose?
- Is there a trap in drain hose?
- Is drain hose clogged?



Is fan rotating?



End

Diagnosis method when water is spitting out

Is the filter clogged?



Check gas pressure and correct it if there was a gas leak.

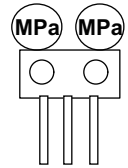

End

4. Service parts information

4-1. Compressor

Diagnosis method of compressor (If outdoor unit LED displays error, refer to troubleshooting)

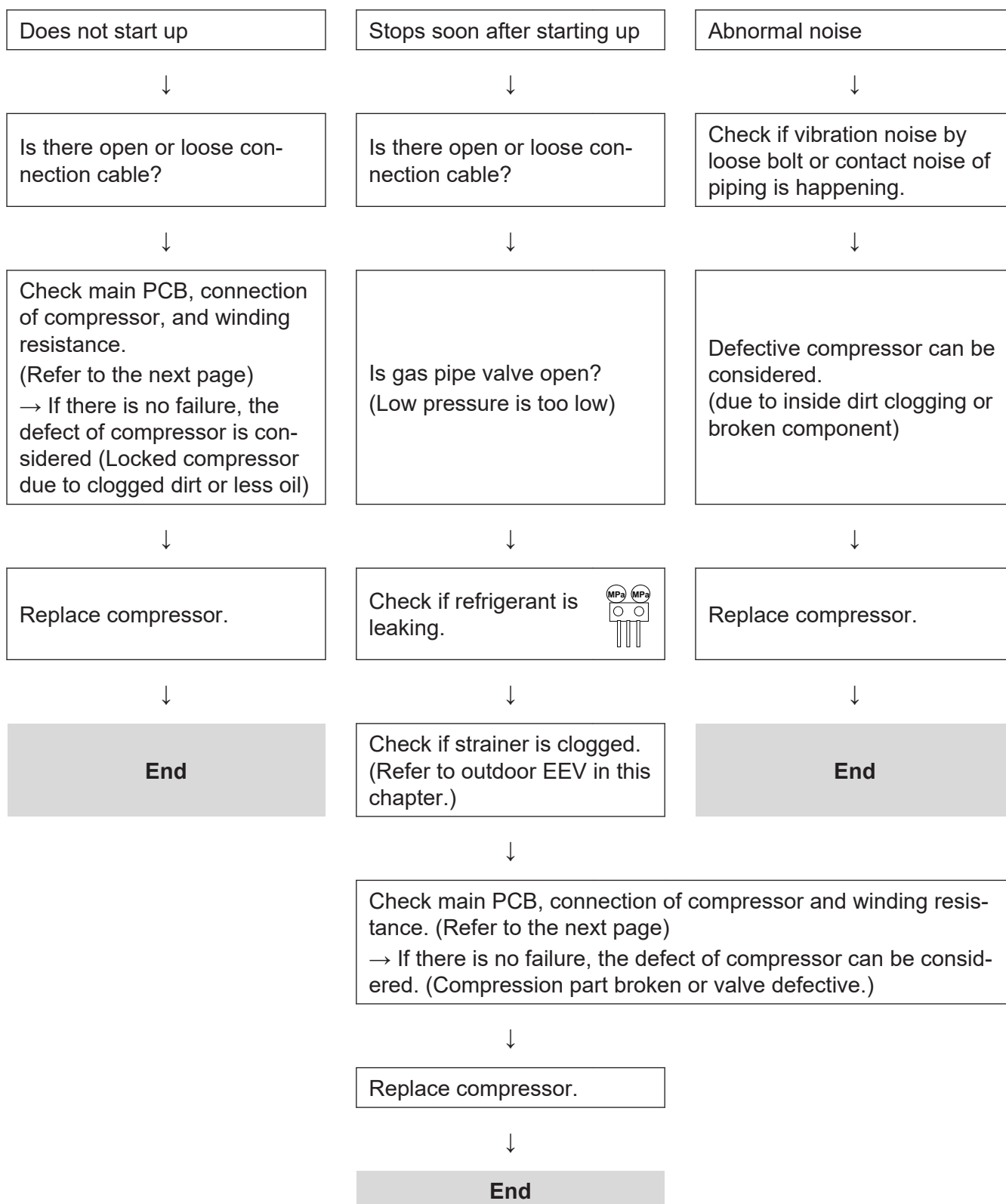

4-2. Inverter compressor

■ Model: AOYG36KRTA

Check point 1. Check connection

- Check terminal connection of compressor (loose or incorrect wiring)

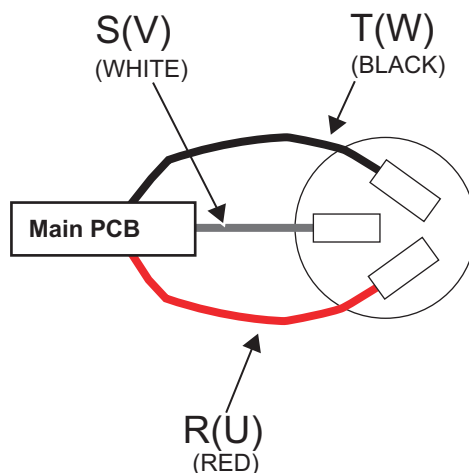

- Check terminal connection of main PCB (loose or incorrect wiring)

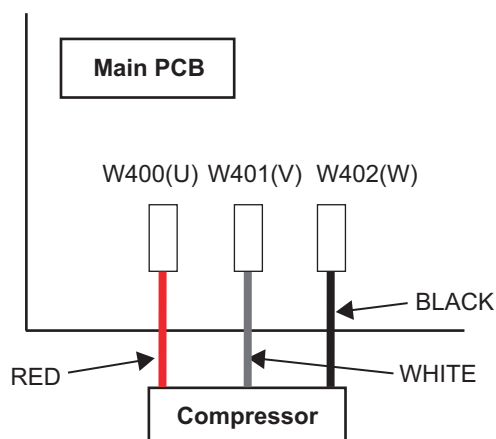

↓

Check point 2. Check winding resistance

Check winding resistance of each terminal.

Resistance value: 2.164 Ω at 25 °C

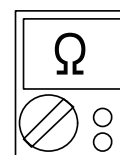
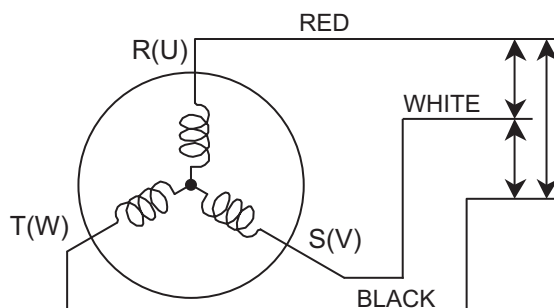

→ If the resistance value is 0 Ω or infinite, replace compressor.

↓

Check point 3. Replace inverter PCB

If check point 1 to 2 do not improve the symptom, replace main PCB.

Models: AOYG45KRTA and AOYG54KRTA

Check point 1. Check connection

- Check terminal connection of compressor (loose or incorrect wiring)

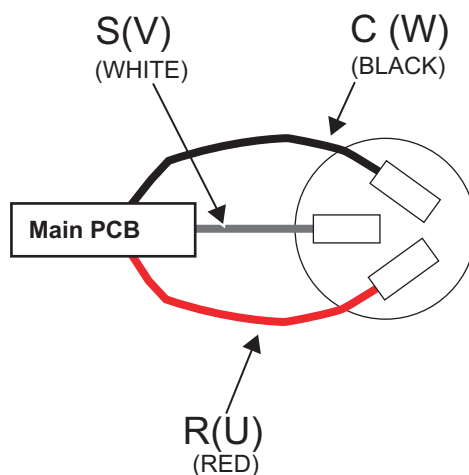

- Check terminal connection of main PCB (loose or incorrect wiring)

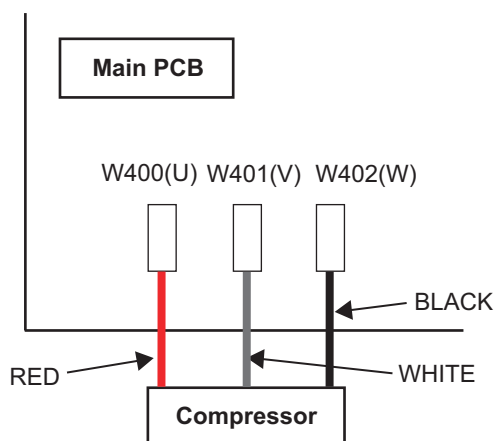

↓

Check point 2. Check winding resistance

Check winding resistance of each terminal.

Resistance value: 1.570 Ω at 20 °C

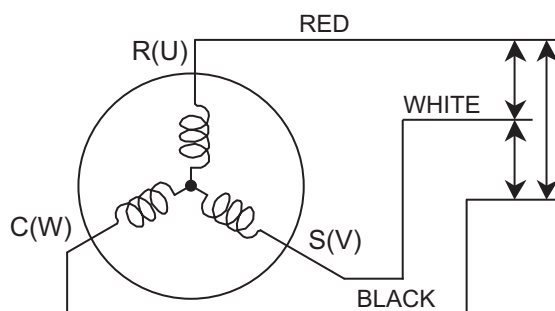

→ If the resistance value is 0 Ω or infinite, replace compressor.

↓

Check point 3. Replace inverter PCB

If check point 1 to 2 do not improve the symptom, replace main PCB.

4-3. Outdoor unit Electronic Expansion Valve (EEV)

■ Models: AOYG36KRTA, AOYG45KRTA, and AOYG54KRTA

Check point 1. Check connections

Check connection of connector. (Loose connector or open cable)

NOTE: For details of wiring diagram, refer to "Wiring diagrams" in Chapter 2. TECHNICAL DATA AND PARTS LIST on page 02-37.

Check point 2. Check coil of EEV

Remove connector, check each winding resistance of coil.

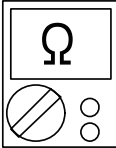
Read wire	Resistance value
1(Red) - 2(Blue)	$46 \Omega \pm 3 \Omega$ at 20°C 
1(Red) - 3(Orange)	
1(Red) - 4(Yellow)	
1(Red) - 5(White)	

→ If Resistance value is abnormal, replace EEV.

Check point 3. Check Voltage from main PCB

Remove connector and check voltage (DC 12 V)

→ If it does not appear, replace main PCB.



Check point 4. Check noise at start up

Turn on the power and check the operation noise.

→ If an abnormal noise does not show, replace main PCB.

Check point 5. Check Opening and Closing Operation of Valve

When valve is closed, it has a temp. difference between inlet and outlet

CLOSE
 Example : Hot Gas

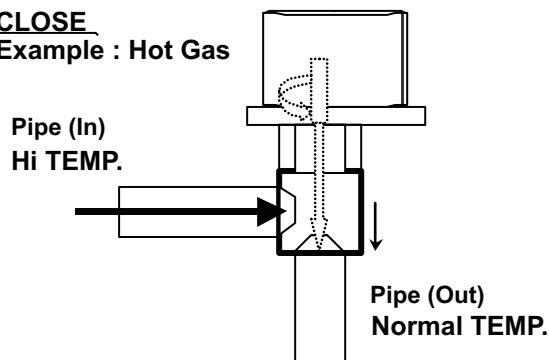

If it is open, it has no temp. difference between inlet and outlet

OPEN
 Example : Hot Gas

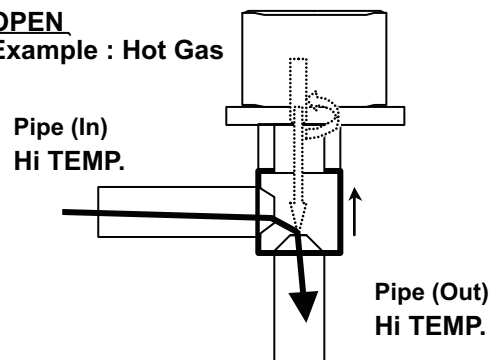

Check point 6. Check strainer

- Strainer normally does not have temperature difference between inlet and outlet as shown below.

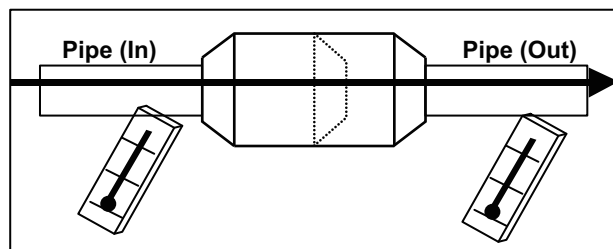

- If there is a difference like shown below, there is a possibility of inside clogged. In this case, replace the strainer.

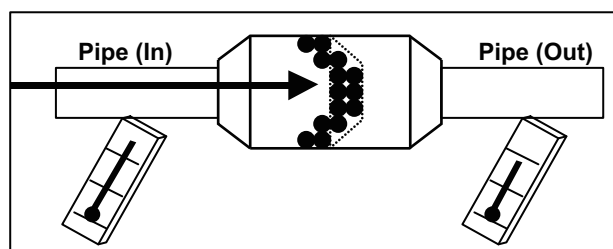

4-4. Indoor unit fan motor

■ Models: AUXG18KVLA, AUXG22KVLA, and AUXG24KVLA

Check point 1. Check rotation of fan

Rotate the fan by hand when operation is off.
 (Check if fan is caught, dropped off or locked motor)
 → If fan or bearing is abnormal, replace it.

Check point 2. Check resistance of indoor fan motor

Refer to below. Circuit-test "Vm" and "GND" terminal

NOTE: Vm: DC voltage, GND: Earth terminal

→ If they are short-circuited (below 300 kΩ), replace indoor fan motor and controller PCB.

Pin number (wire color)	Terminal function (symbol)
1 (Red)	DC voltage (Vm)
2	No function
3	No function
4 (Black)	Earth terminal (GND)
5 (White)	Control voltage (Vcc)
6 (Yellow)	Speed command (Vsp)
7 (Brown)	Feed back (FG)

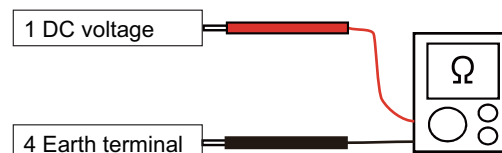

4-5. Outdoor unit fan motor

■ Models: AOYG36KRTA, AOYG45KRTA, and AOYG54KRTA

Check point 1. Check rotation of fan

Rotate the fan by hand when operation is off.
 (Check if fan is caught, dropped off or locked motor)
 → If fan or bearing is abnormal, replace it.

Check point 2. Check resistance of outdoor fan motor

Refer to below. Circuit-test "Vm" and "GND" terminal

NOTE: Vm: DC voltage, GND: Earth terminal

→ If they are short-circuited (below 300 kΩ), replace outdoor fan motor and controller PCB.

Pin number (wire color)	Terminal function (symbol)
1 (Red)	DC voltage (Vm)
2	No function
3	No function
4 (Black)	Earth terminal (GND)
5 (White)	Control voltage (Vcc)
6 (Yellow)	Speed command (Vsp)
7 (Brown)	Feed back (FG)

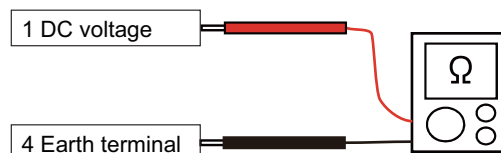

4-6. Pressure switch

■ Models: AOYG36KRTA, AOYG45KRTA, and AOYG54KRTA

- Type of contact

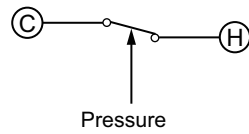

- Characteristics of pressure switch

Pressure switch 1	
Contact: Short → Open	4.2 — 4.05 MPa
Contact: Open → Short	3.2 ± 0.15 MPa

36/45/54 model: P770

4-7. 4-way valve coil (solenoid coil)/4-way valve

■ Models: AOYG36KRTA, AOYG45KRTA, and AOYG54KRTA

Check point 1. Check connection

- Check the connection of connector P60.

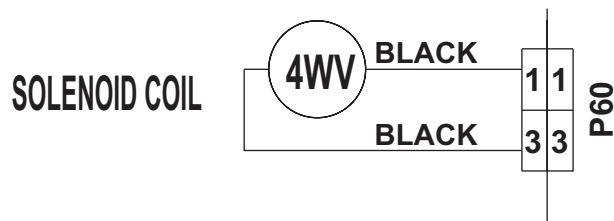

↓

Check Point 2 : Check solenoid coil

Remove P60 from PCB and check the resistance value of coil.

Resistance Value $\approx 1.97 \text{ k}\Omega$

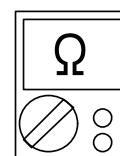
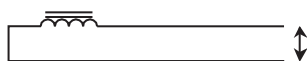

→ If it is Open or abnormal resistance value, replace solenoid coil.

↓

Check Point 3: Check operation of 4 way valve

Check each piping temperature, and confirm the location of the valve by the temperature difference

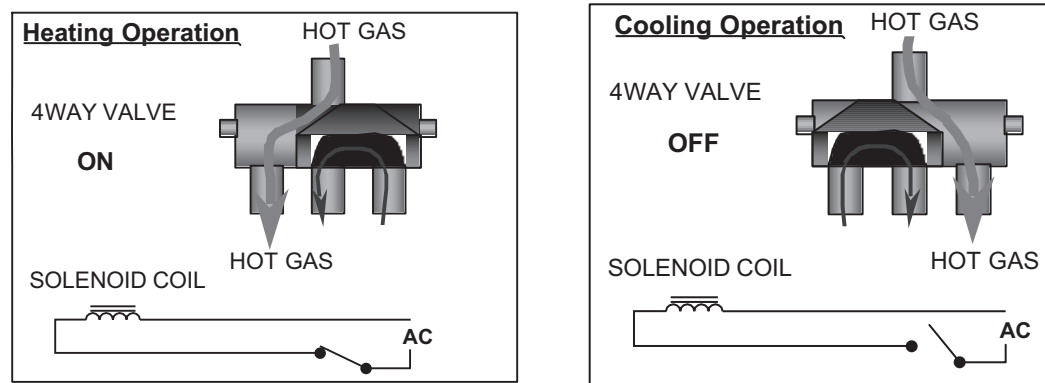

→ If the valve location is not proper, replace 4 way valve.

↓

Check Point 4: Replace main PCB

If none of Checks 1 to 3 apply, replace the main PCB.

5. Thermistor resistance values

5-1. Indoor unit

■ Room temperature thermistor

Temperature (°C)	Resistance (kΩ)	Voltage (V)
-10.0	58.25	0.73
-5.0	44.03	0.93
0.0	33.62	1.15
5.0	25.93	1.39
10.0	20.18	1.66
15.0	15.84	1.94
20.0	12.54	2.22
25.0	10.00	2.50
30.0	8.04	2.77
35.0	6.51	3.03
40.0	5.30	3.27
45.0	4.35	3.49

■ Heat exchanger temperature thermistor

Temperature (°C)	Resistance (kΩ)	Voltage (V)
-30.0	1,013.09	0.24
-25.0	729.08	0.32
-20.0	531.55	0.43
-15.0	382.31	0.56
-10.0	312.27	0.69
-5.0	292.90	0.73
0.0	168.60	1.14
5.0	129.84	1.39
10.0	100.91	1.65
15.0	79.12	1.93
20.0	62.55	2.22
25.0	49.84	2.50
30.0	40.01	2.78
35.0	32.35	3.03
40.0	26.34	3.27
45.0	21.58	3.49
50.0	17.79	3.69
55.0	14.75	3.86
60.0	12.30	4.01
65.0	10.32	4.14

5-2. Outdoor unit

■ Heatsink thermistor

Temperature (°C)	Resistance (kΩ)	Voltage (V)
-30.0	94.26	0.08
-25.0	67.95	0.11
-20.0	49.62	0.15
-15.0	36.68	0.20
-10.0	27.42	0.26
-5.0	20.73	0.34
0.0	15.83	0.43
5.0	12.21	0.55
10.0	9.50	0.68
15.0	7.46	0.84
20.0	5.90	1.01
25.0	4.71	1.21
30.0	3.78	1.42
35.0	3.06	1.64
40.0	2.50	1.88
45.0	2.05	2.11
50.0	1.69	2.35
55.0	1.40	2.58
60.0	1.17	2.81
65.0	0.98	3.02
70.0	0.83	3.22
75.0	0.70	3.41
80.0	0.60	3.58
85.0	0.51	3.73
90.0	0.44	3.87
95.0	0.38	3.99
100.0	0.33	4.10

■ Discharge temperature thermistor

Temperature (°C)	Resistance (kΩ)	Voltage (V)
-30.0	1,013.11	0.06
-25.0	729.09	0.09
-20.0	531.56	0.12
-15.0	392.31	0.16
-10.0	292.91	0.21
-5.0	221.09	0.28
0.0	168.60	0.36
5.0	129.84	0.46
10.0	100.91	0.57
15.0	79.12	0.71
20.0	62.55	0.86
25.0	49.84	1.03
30.0	40.01	1.23
35.0	32.35	1.43
40.0	26.34	1.65
45.0	21.58	1.88
50.0	17.79	2.11
55.0	14.75	2.34
60.0	12.30	2.57
65.0	10.32	2.79
70.0	8.70	3.00
75.0	7.36	3.19
80.0	6.27	3.37
85.0	5.36	3.54
90.0	4.60	3.69
95.0	3.96	3.83
100.0	3.43	3.96
105.0	2.98	4.07
110.0	2.60	4.17
115.0	2.27	4.26
120.0	2.00	4.33

■ Heat exchanger temperature thermistor

Temperature (°C)	Resistance (kΩ)	Voltage (V)
-30.0	95.58	0.24
-25.0	68.90	0.32
-20.0	50.31	0.43
-15.0	37.19	0.57
-10.0	27.81	0.73
-5.0	21.02	0.92
0.0	16.05	1.14
5.0	12.38	1.39
10.0	9.63	1.65
15.0	7.56	1.93
20.0	5.98	2.21
25.0	4.77	2.49
30.0	3.84	2.77
35.0	3.11	3.02
40.0	2.53	3.26
45.0	2.08	3.48
50.0	1.71	3.68
55.0	1.42	3.85
60.0	1.19	4.00
65.0	1.00	4.13
70.0	0.84	4.25
75.0	0.71	4.35
80.0	0.61	4.43

■ Outdoor temperature thermistor

Temperature (°C)	Resistance (kΩ)	Voltage (V)
-30.0	224.33	0.73
-25.0	159.71	0.97
-20.0	115.24	1.25
-15.0	84.21	1.56
-10.0	62.28	1.90
-5.0	46.58	2.26
0.0	35.21	2.61
5.0	26.88	2.94
10.0	20.72	3.25
15.0	16.12	3.52
20.0	12.64	3.76
25.0	10.00	3.97
30.0	7.97	4.14
35.0	6.40	4.28
40.0	5.18	4.41
45.0	4.21	4.51
50.0	3.45	4.59
55.0	2.85	4.65

4. CONTROL AND FUNCTIONS

CONTENTS

4. CONTROL AND FUNCTIONS

1. Compressor frequency control	04-1
1-1. Cooling operation	04-1
1-2. Heating operation	04-5
1-3. Dry operation	04-5
1-4. Compressor frequency at normal start-up	04-6
1-5. Compressor frequency limitation by outdoor temperature	04-8
2. Auto changeover operation	04-10
3. Fan control	04-12
3-1. Indoor fan control.....	04-12
3-2. Outdoor fan control	04-18
4. Louver control	04-20
4-1. Individual louver control(For Compact cassette type)	04-20
4-2. All louver control(For Compact cassette type)	04-20
4-3. Swing operation(For Compact cassette type).....	04-21
5. Timer operation control	04-22
5-1. Wireless remote control	04-22
5-2. Wired remote control	04-24
6. Defrost operation control	04-27
6-1. Defrost operation in heating operation stopped	04-28
7. Various control	04-29
7-1. Auto restart	04-29
7-2. 10 °C HEAT operation	04-29
7-3. ECONOMY operation	04-29
7-4. Fresh air control.....	04-29
7-5. Compressor preheating	04-30
7-6. External electrical heater control	04-30
7-7. Electronic expansion valve control	04-30
7-8. Drain pump control	04-31
7-9. Prevention to restart for 3 minutes (3 minutes st)	04-32
7-10. 4-way valve control	04-32
7-11. Peak cut operation	04-32
7-12. Outdoor unit low noise operation	04-33
8. Various protections	04-34
8-1. Discharge gas temperature over-rise prevention control	04-34
8-2. Anti-freezing control (cooling and dry mode)	04-34
8-3. Current release control	04-35
8-4. Low pressure protection control (cooling mode)	04-36
8-5. Indoor unit fan motor over temperature protection.....	04-37
8-6. Compressor temperature protection	04-37
8-7. High pressure protection	04-38

CONTENTS (continued)

8-8. Low outdoor temperature protection	04-38
8-9. High temperature and high pressure release control	04-38

1. Compressor frequency control

1-1. Cooling operation

A sensor (room temperature thermistor) built in the indoor unit body will usually perceive difference or variation between a set temperature and present room temperature, and controls the operation frequency of the compressor.

- If the room temperature is 6.0 °C higher than a set temperature, the compressor operation frequency will attain to maximum performance.
- If the room temperature is 1.0 °C lower than a set temperature, the compressor will be stopped.
- When the room temperature is within the range of +6.0°C to -1.0°C of the setting temperature, the compressor frequency is controlled within the range shown in the table below. However, the maximum frequency is limited in the range shown in the figure below based on the indoor fan mode and the outdoor temperature.

■ Compact cassette type

- Compressor frequency range

Connected model name	Minimum frequency	Maximum frequency
AOYG36KRTA	15 rps	98 rps
AOYG45KRTA	17 rps	95 rps
AOYG54KRTA	17 rps	95 rps

• Limit of maximum speed based on outdoor temperature

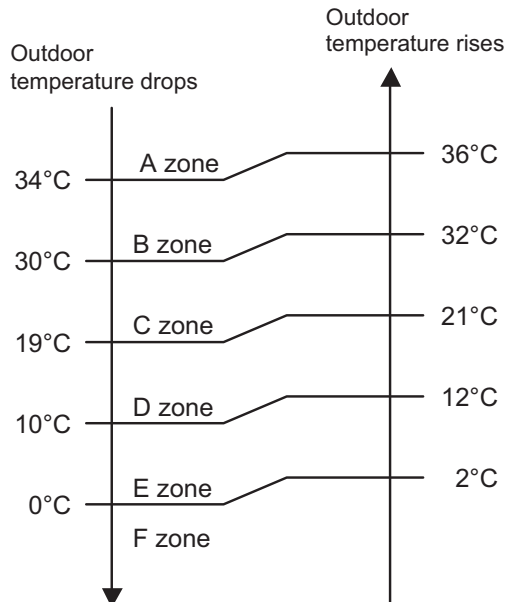

Unit: rps

– Model: AOYG36KRTA

Model name	Outdoor temperature zone	Indoor unit fan mode			
		HIGH	MED	LOW	QUIET
AUXG18KVLA	A zone	98	64	49	32
	B zone	98	64	49	32
	C zone	77	49	40	32
	D zone	49	40	34	26
	E zone	49	40	34	26
	F zone	49	40	34	26

– Models: AOYG45KRTA and AOYG54KRTA

Model name	Outdoor temperature zone	Indoor unit fan mode			
		HIGH	MED	LOW	QUIET
AUXG18KVLA	A zone	95	66	51	33
	B zone	95	66	51	33
	C zone	80	51	41	33
	D zone	51	41	35	27
	E zone	51	41	35	27
	F zone	51	41	35	27
AUXG22KVLA AUXG24KVLA	A zone	95	66	51	33
	B zone	95	66	51	33
	C zone	80	51	41	33
	D zone	56	41	35	27
	E zone	56	41	35	27
	F zone	56	41	35	27

■ Slim duct type

- Compressor frequency range

Connected model name	Maximum frequency	Minimum frequency
AOYG36KRTA	98 rps	15 rps
AOYG54KRTA	95 rps	17 rps

- Limit of maximum speed based on outdoor temperature

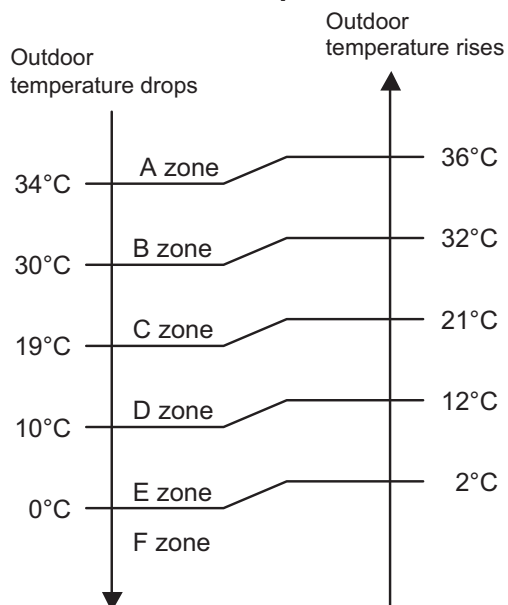

Unit: rps

- Model: AOYG36KRTA

Model name	Outdoor temperature zone	Indoor unit fan mode			
		HIGH	MED	LOW	QUIET
ARXG18KLLAP	A zone	98	64	49	32
	B zone	98	64	49	32
	C zone	77	49	40	32
	D zone	49	40	34	26
	E zone	49	40	34	26
	F zone	49	40	34	26

- Model: AOYG54KRTA

Model name	Outdoor temperature zone	Indoor unit fan mode			
		HIGH	MED	LOW	QUIET
ARXG18KLLAP	A zone	95	66	51	33
	B zone	95	66	51	33
	C zone	80	51	41	33
	D zone	51	41	35	27
	E zone	51	41	35	27
	F zone	51	41	35	27

■ Medium static pressure duct type

- Compressor frequency range

Connected model name	Minimum frequency	Maximum frequency
AOYG45KRTA	17 rps	95 rps
AOYG54KRTA	17 rps	95 rps

- Limit of maximum speed based on outdoor temperature

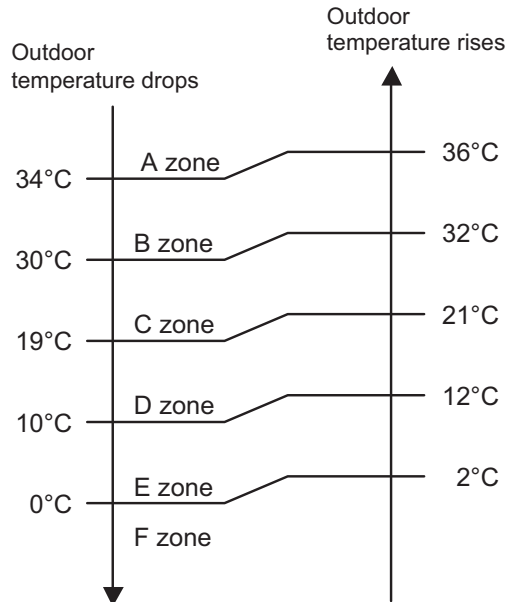

Unit: rps

– Models: AOYG45KRTA and AOYG54KRTA

Model name	Outdoor temperature zone	Indoor unit fan mode			
		HIGH	MED	LOW	QUIET
ARXG22KMLA ARXG24KMLA	A zone	95	66	51	33
	B zone	95	66	51	33
	C zone	80	51	41	33
	D zone	56	41	35	27
	E zone	56	41	35	27
	F zone	56	41	35	27

1-2. Heating operation

A sensor (room temperature thermistor) built in indoor unit body will usually perceive difference or variation between setting temperature and present room temperature, and controls operation frequency of compressor.

- If the room temperature is 6.0 °C lower than a set temperature, the compressor operation frequency will attain to maximum performance.
- If the room temperature is 1.0 °C higher than a set temperature, the compressor will be stopped.
- When the room temperature is within the range of +1.0°C to -6.0°C of the setting temperature, the compressor frequency is controlled within the range shown below.

- **Compressor frequency range**

Connected model name	Minimum frequency	Maximum frequency
AOYG36KRTA	15 rps	120 rps
AOYG45KRTA	17 rps	120 rps
AOYG54KRTA	17 rps	120 rps

1-3. Dry operation

The compressor rotation frequency shall change according to the temperature, set temperature, and room temperature variation which the room temperature sensor of the indoor unit has detected as shown in the table below.

Zone is defined by set temperature and room temperature.

- **Compressor frequency range**

Unit: rps

Connected model name	Outdoor temperature zone	Operating frequency
AOYG36KRTA	X zone	32
	J zone	32
	Y zone	0
AOYG45KRTA AOYG54KRTA	X zone	33
	J zone	33
	Y zone	0

- **Compressor control based on room temperature**

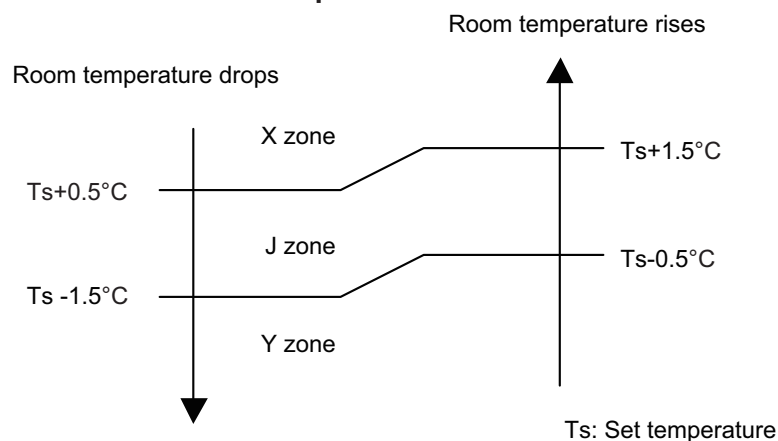

1-4. Compressor frequency at normal start-up

■ Model: AOYG36KRTA

Compressor frequency soon after starting is controlled as below.

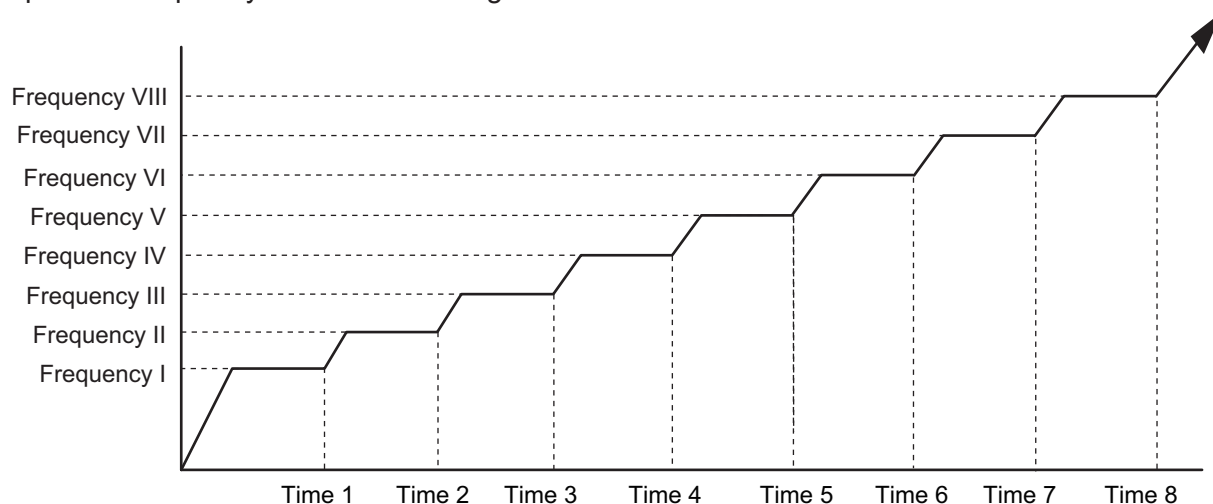

- Normal operation

Frequency (rps)	I	II	III	IV	V	VI	VII	VIII
	25	42	53	61	65	75	85	92
Time (sec)	1	2	3	4	5	6	7	8
	90	150	270	330	390	450	570	630

- Special operation

Frequency (rps)	I	II	III	IV	V	VI	VII	VIII
	25	42	53	61	65	75	85	92
Time (sec)	1	2	3	4	5	6	7	8
	225	305	605	665	725	785	855	1,000

NOTES:

- Normal operation:
 - Cooling and dry mode
 - Below 3 hours from the compressor stop and the compressor thermistor $\geq 15\text{ }^{\circ}\text{C}$
 - After defrost operation
 - Other than when the compressor starts for the first time since the breaker turns on
- Special operation:
 - Other than the normal operation condition
 - When the compressor starts for the first time since the breaker turns on

Models: AOYG45KRTA and AOYG54KRTA

Compressor frequency soon after starting is controlled as below.

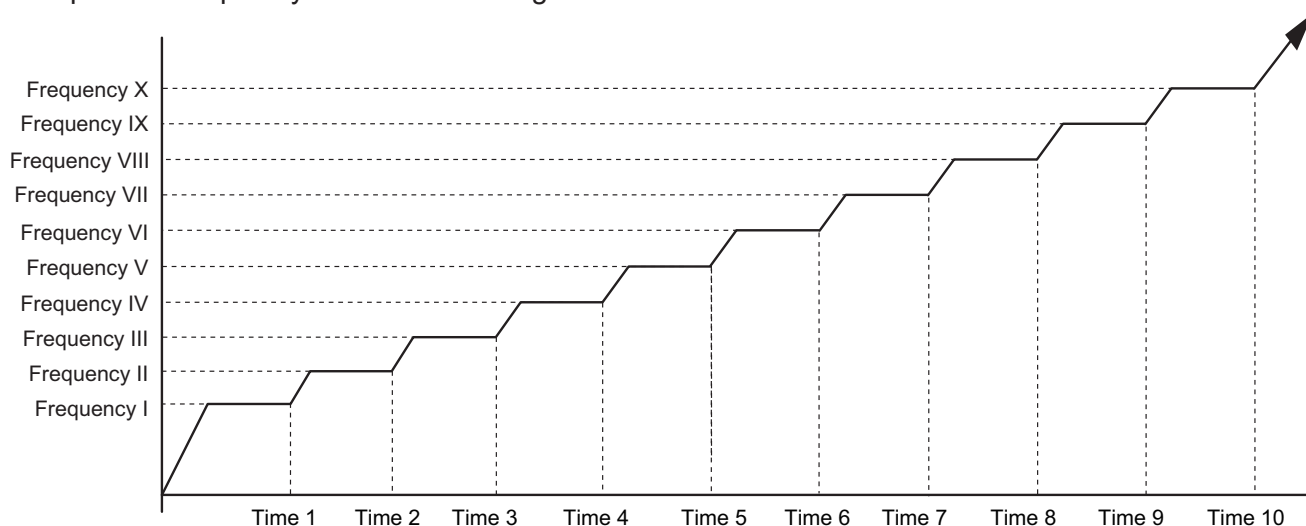

- Normal operation

Frequency (rps)	I	II	III	IV	V	VI	VII	VIII	IX	X
	41	46	51	57	60	72	81	91	100	110
Time (sec)	1	2	3	4	5	6	7	8	9	10
	60	120	180	240	360	420	480	540	600	660

- Special operation

Frequency (rps)	I	II	III	IV	V	VI	VII	VIII	IX	X
	41	46	51	57	60	72	81	91	100	110
Time (sec)	1	2	3	4	5	6	7	8	9	10
	120	185	245	305	605	665	725	785	845	1,000

NOTES:

- Normal operation:
 - Cooling and dry mode
 - Below 3 hours from the compressor stop and the compressor thermistor $\geq 15\text{ }^{\circ}\text{C}$
 - After defrost operation
 - Other than when the compressor starts for the first time since the breaker turns on
- Special operation:
 - Other than the normal operation condition
 - When the compressor starts for the first time since the breaker turns on

1-5. Compressor frequency limitation by outdoor temperature

The minimum compressor frequency is limited by outdoor temperature as below.

- Cooling/Dry mode

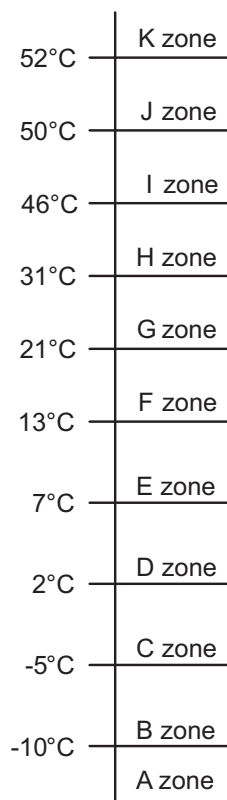

Model name	Outdoor temperature zone	Limitation of compressor frequency
AOYG36KRTA	A zone	55 rps
	B zone	52 rps
	C zone	47 rps
	D zone	39 rps
	E zone	33 rps
	F zone	25 rps
	G zone	18 rps
	H zone	20 rps
	I zone	20 rps
	J zone	21 rps
	K zone	24 rps
AOYG45KRTA AOYG54KRTA	A zone	50 rps
	B zone	47 rps
	C zone	40 rps
	D zone	30 rps
	E zone	22 rps
	F zone	20 rps
	G zone	16 rps
	H zone	16 rps
	I zone	17 rps
	J zone	23 rps
	K zone	28 rps

- Heating mode

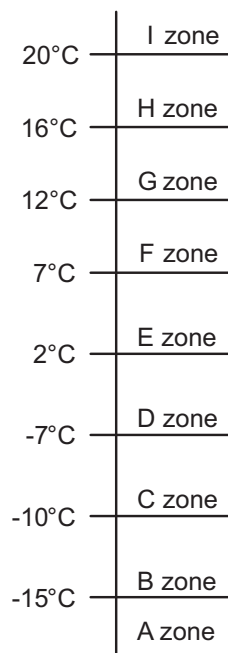

Model name	Outdoor temperature zone	Limitation of compressor frequency
AOYG36KRTA	A zone	58 rps
	B zone	52 rps
	C zone	43 rps
	D zone	38 rps
	E zone	28 rps
	F zone	23 rps
	G zone	20 rps
	H zone	17 rps
	I zone	17 rps
AOYG45KRTA AOYG54KRTA	A zone	46 rps
	B zone	42 rps
	C zone	35 rps
	D zone	32 rps
	E zone	23 rps
	F zone	20 rps
	G zone	17 rps
	H zone	13 rps
	I zone	16 rps

2. Auto changeover operation

When the air conditioner is set to AUTO mode by remote controller, operation starts in the optimum mode from among heating, cooling, dry and monitoring modes. During operation, the optimum mode is automatically switched in accordance with temperature changes. The temperature can be set between 18°C and 30°C in 1.0°C steps.

- When operation starts, indoor fan and outdoor fan are operated for around 1 minute. Room temperature and outdoor temperature are sensed, and the operation mode is selected in accordance with the table below.

Room temperature	Operation mode
$Tr > Ts + 2^{\circ}\text{C}$	Cooling
$Ts + 2^{\circ}\text{C} \geq Tr \geq Ts - 2^{\circ}\text{C}$	Middle zone
$Tr < Ts - 2^{\circ}\text{C}$	Heating

Tr: Room temperature

Ts: Setting temperature

NOTE: When the operation mode is middle zone, indoor unit operation mode is selected as below.

- Same operation mode is selected as outdoor unit.
If outdoor unit is operating in cooling and heating mode, indoor unit will be operated by the same operation mode.
- Selected by outdoor temperature.
If outdoor unit is operating in other than cooling and heating mode, indoor unit will be operated according to the outdoor temperature as below.

Outdoor temp.	Operation mode
25°C or more	Cooling
Less than 25°C	Heating

- When the compressor was stopped for 6 consecutive minutes by temperature control function after the cooling or heating mode was selected as above, operation is switched to monitoring mode and the operation mode selection is done again.
- When the middle zone is selected on the predetermining of the operation mode, the operation mode before the changing to the monitoring mode is selected.

Operation flow chart

Ts: Setting temperature

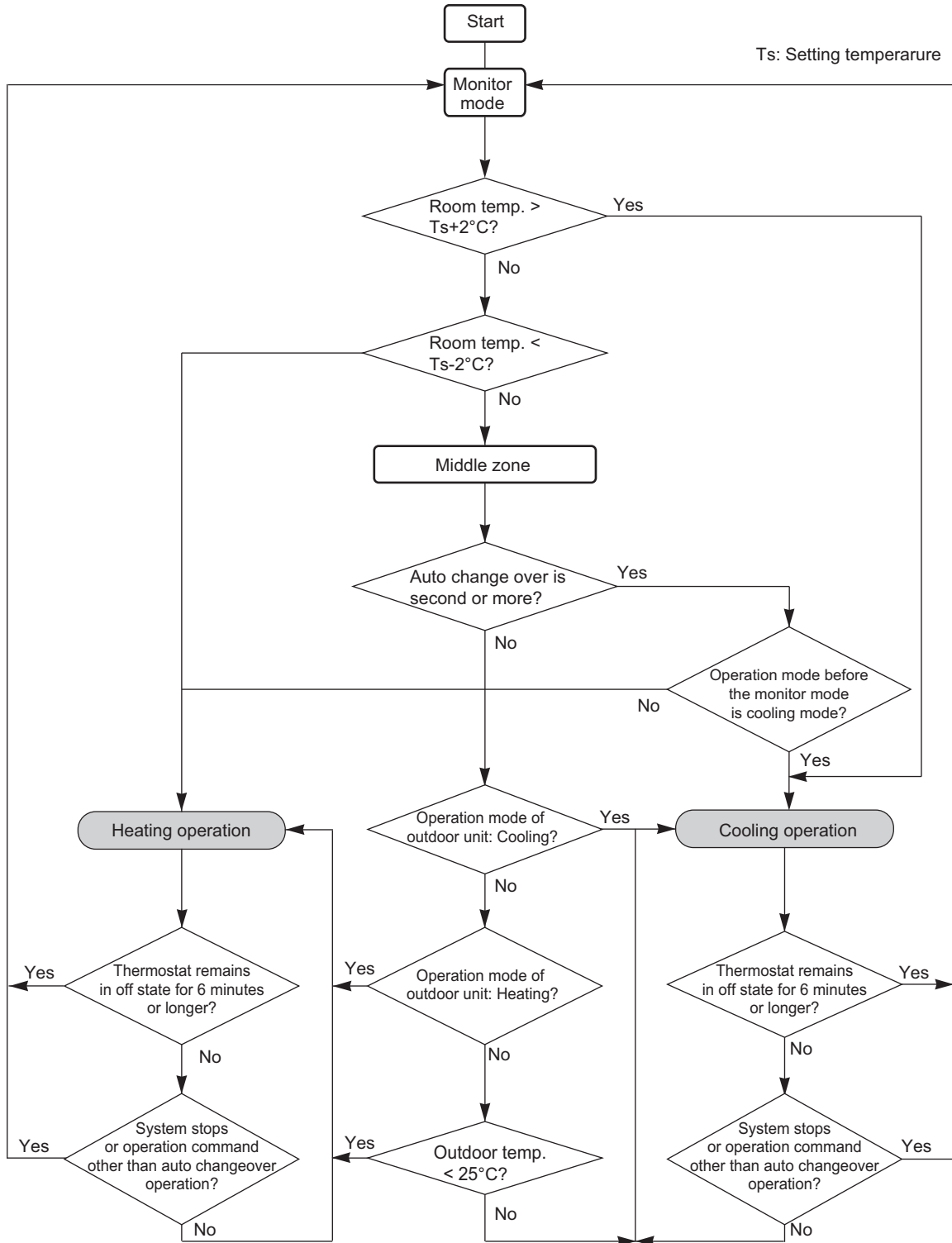

CONTROL AND FUNCTIONS

CONTROL AND FUNCTIONS

3. Fan control

Tr: Room temperature

Ts: Setting temperature

3-1. Indoor fan control

■ Compact cassette type

● Fan speed

Indoor fan speed is defined as below.

Operation mode	Fan mode	Speed (rpm)		
		AUXG18KVLA	AUXG22KVLA	AUXG24KVLA
Heating	HIGH	830	880	960
	MED+	770	850	930
	MED	730	800	880
	LOW	630	740	740
	QUIET	500	580	580
	Cool air prevention	400	400	400
	S-LOW	300	300	300
Cooling/Fan	HIGH	730	860	960
	MED	630	770	850
	LOW	540	650	650
	QUIET	460	500	500
	Soft quiet	400*1	400*1	400*1
	S-LOW	300*2	300*2	300*2
Dry		X zone: 460 J zone: 460	X zone: 500 J zone: 500	X zone: 500 J zone: 500

*1: Fan mode only

*2: Cooling mode only

● Fan operation

Airflow can be switched in 5 steps such as AUTO, QUIET, LOW, MED, HIGH while indoor unit fan only runs.

When fan mode is set at AUTO, it operates on MED fan speed.

● Cooling operation

Switch the airflow AUTO, and indoor fan motor will run according to room temperature, as below.

On the other hand, if switched in HIGH—QUIET, indoor motor will run at a constant airflow of COOL operation modes QUIET, LOW, MED, HIGH as shown in “Fan speed” above.

Airflow change over (Cooling: Auto)

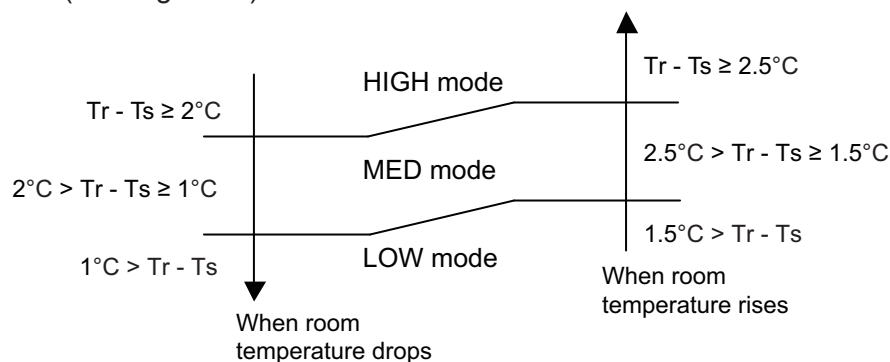

● Dry operation

During dry operation, fan speed setting can not be changed as shown in “Fan speed” above.

● Heating operation

Switch the airflow AUTO, and the indoor fan motor will run according to a room temperature, as below.

On the other hand, if switched in HIGH—QUIET, the indoor motor will run at a constant airflow of HEAT operation modes QUIET, LOW, MED, HIGH as shown in “Fan speed” above.

Airflow change over (Heating: Auto)

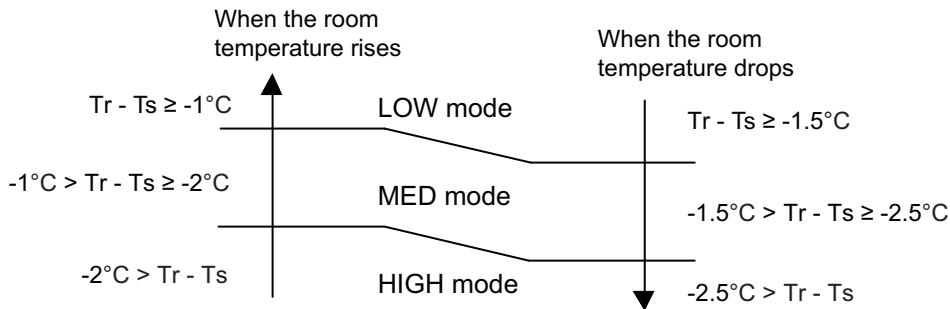

● Cool air prevention control (heating mode)

The maximum value of the indoor fan speed is set as shown below, based on the detected temperature by the indoor heat exchanger sensor on heating mode.

• Normal operation

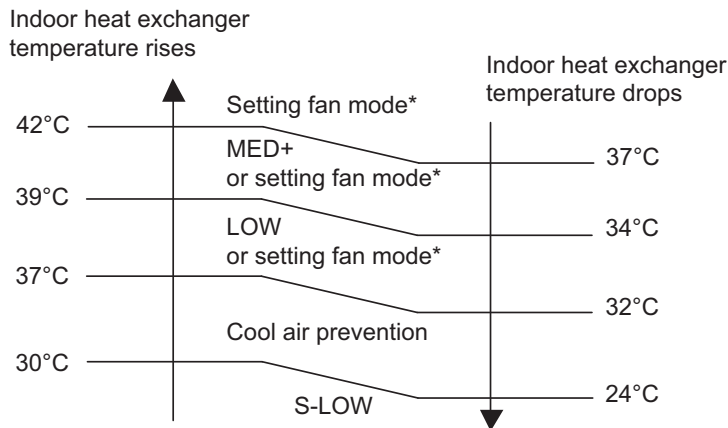

*: Lower speed is selected.

13 minutes later:

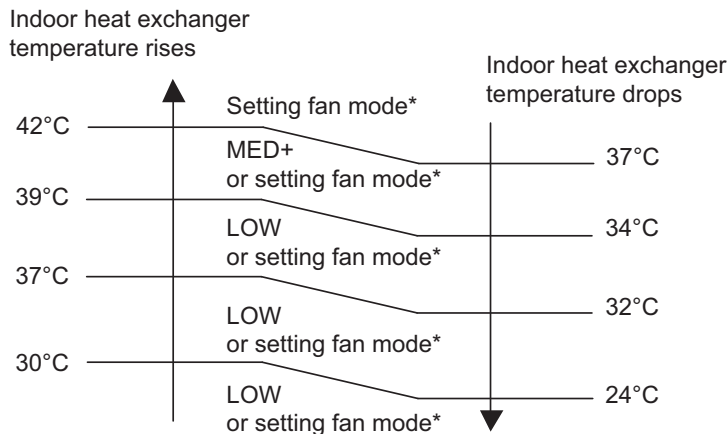

*: Lower speed is selected.

• **Powerful operation**

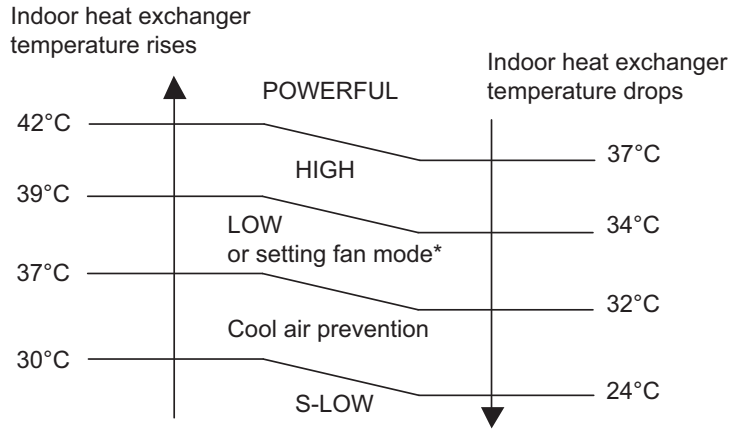

13 minutes later:

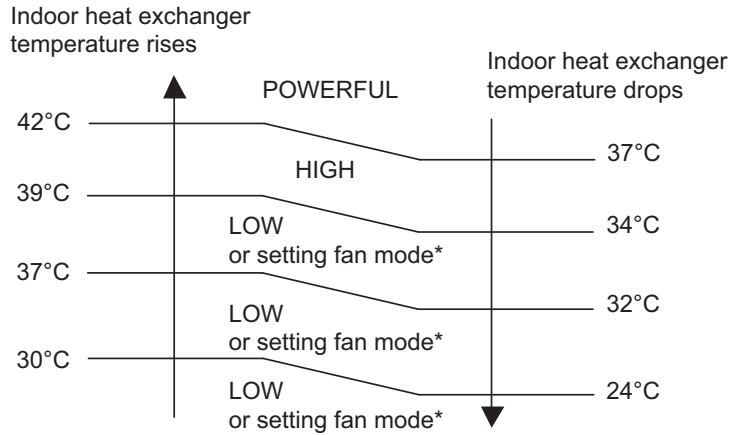

• **10 °C HEAT operation**

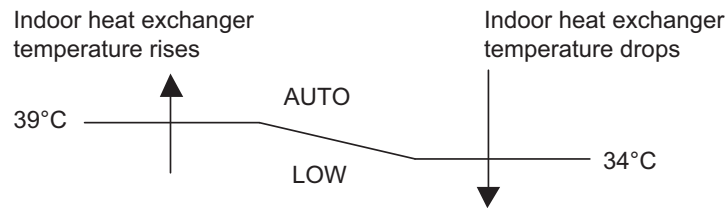

● **Moisture return prevention control (cooling and dry mode)**

Switch the airflow AUTO at cooling mode, and the indoor fan motor will run as shown below.

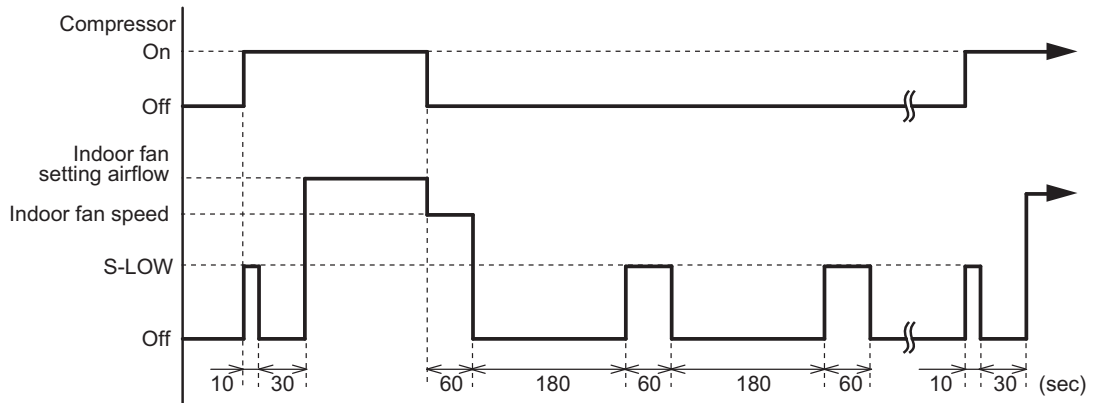

■ Slim duct and Medium static pressure duct types

● Fan speed

Indoor fan speed is defined as below.

Operation mode	Fan mode	Speed (rpm)	
		ARXG18KLLAP	ARXG22KMLA ARXG24KMLA
Heating	HIGH	1,380	830
	MED	1,300	700
	LOW	1,220	600
	QUIET	1,140	550
	S-LOW	600	350
Cooling/Fan	HIGH	1,380	830
	MED	1,300	700
	LOW	1,220	600
	QUIET	1,140	550
	Soft quiet	600* ¹	350* ¹
	S-LOW	600* ²	350* ²
Dry		X zone: 1,140 J zone: 1,140	X zone: 550 J zone: 550

*1: Fan mode only

*2: Cooling mode only

● Fan operation

Airflow can be switched in 5 steps such as AUTO, QUIET, LOW, MED, HIGH while indoor unit fan only runs.

When fan mode is set at AUTO, it operates on MED fan speed.

● Cooling operation

Switch the airflow AUTO, and indoor fan motor will run according to room temperature, as below.

On the other hand, if switched in HIGH—QUIET, indoor motor will run at a constant airflow of COOL operation modes QUIET, LOW, MED, HIGH as shown in “Fan speed” above.

Airflow change over (Cooling: Auto)

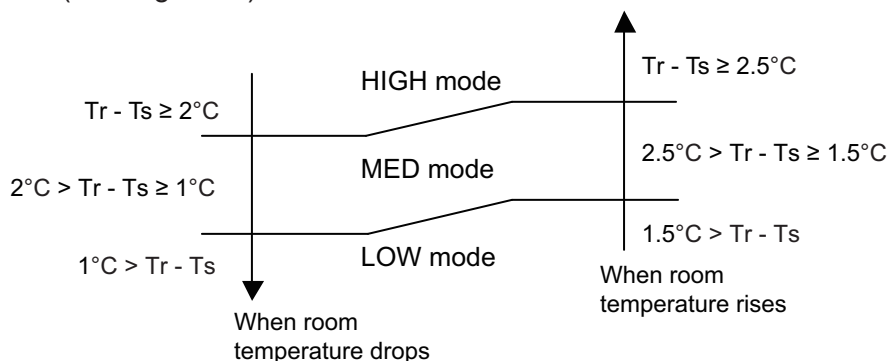

● Dry operation

During dry operation, fan speed setting can not be changed as shown in “Fan speed” above.

● Heating operation

Switch the airflow AUTO, and the indoor fan motor will run according to a room temperature, as below.

On the other hand, if switched in HIGH—QUIET, the indoor motor will run at a constant airflow of HEAT operation modes QUIET, LOW, MED, HIGH as shown in “Fan speed” above.

Airflow change over (Heating: Auto)

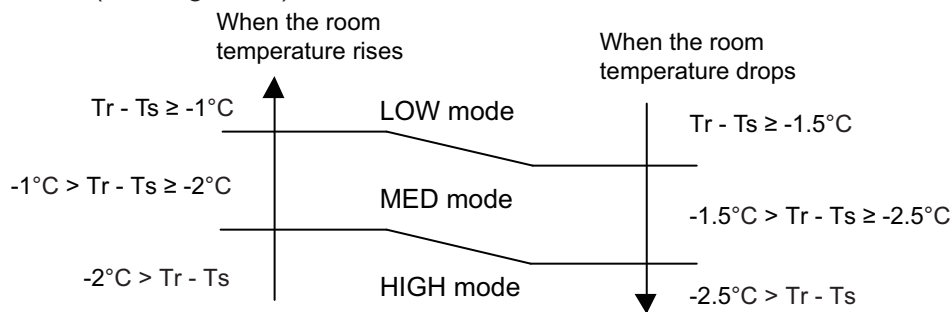

● Cool air prevention control (heating mode)

The maximum value of the indoor fan speed is set as shown below, based on the detected temperature by the indoor heat exchanger sensor on heating mode.

• Normal operation

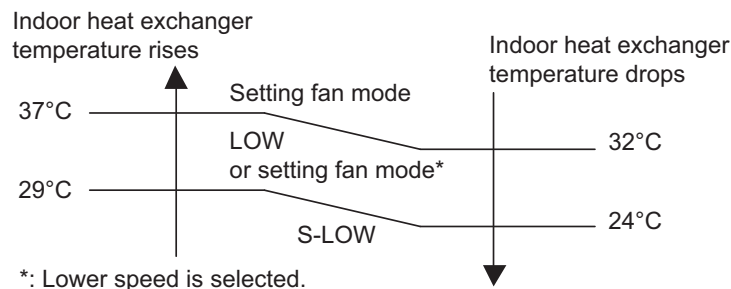

13 minutes later:

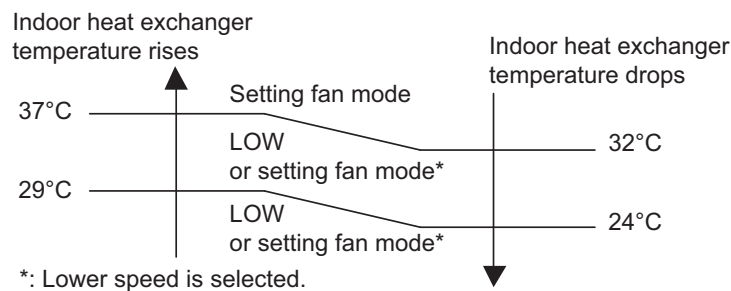

• 10 °C HEAT operation

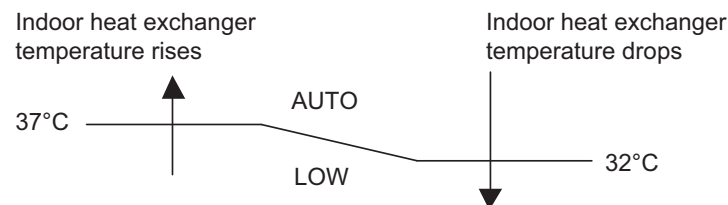

● Moisture return prevention control (cooling and dry mode)

Switch the airflow AUTO at cooling mode, and the indoor fan motor will run as shown below.

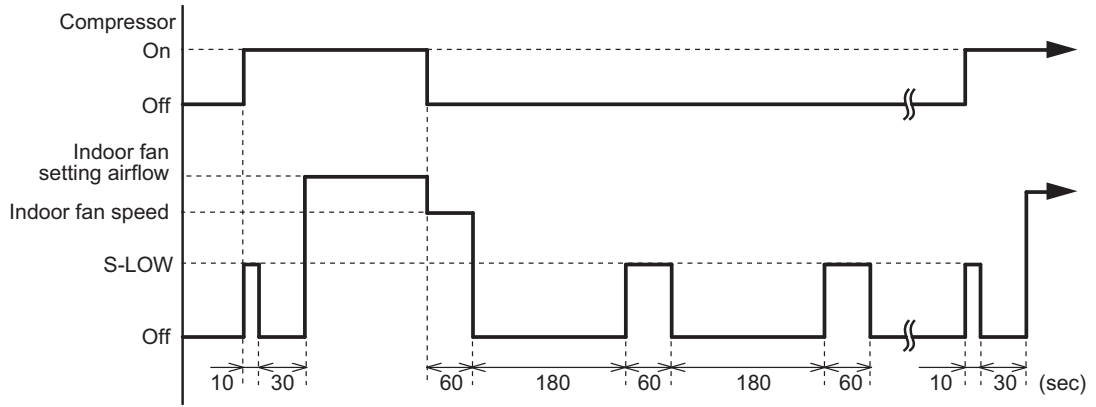

CONTROL AND FUNCTIONS

CONTROL AND FUNCTIONS

3-2. Outdoor fan control

■ Outdoor fan motor

This outdoor unit has a DC fan motor. (Control method is different between AC and DC motors.)

■ Fan speed

● Model: AOYG36KRTA

Fan speed is defined by outdoor temperature and compressor frequency.

Unit: rpm

Fan step	Cooling or dry	Heating
13	830	—
12	830	—
11	740	—
10	700	830
9	650	740
8	570	690
7	570	620
6	570	590
5	570	480
4	540	410
3	480	340
2	400	270
1	270	200
S-HIGH	—	830

- When the compressor frequency increases, the outdoor fan speed also changes to the higher speed.
- When the compressor frequency decreases, the outdoor fan speed also changes to the lower speed.

NOTE: After defrost control on the heating mode, the fan speed is kept higher regardless of the compressor frequency.

Fan speed after defrost control: 830 rpm

● Models: AOYG45KRTA and AOYG54KRTA

Fan speed is defined by outdoor temperature and compressor frequency.

Unit: rpm

Fan step	Cooling or dry	Heating
13	990	—
12	920	—
11	860	—
10	800	990
9	740	900
8	650	820
7	600	740
6	530	650
5	490	540
4	400	460
3	330	380
2	270	290
1	200	200
S-HIGH	—	990

- When the compressor frequency increases, the outdoor fan speed also changes to the higher speed.
- When the compressor frequency decreases, the outdoor fan speed also changes to the lower speed.

NOTE: After defrost control on the heating mode, the fan speed is kept higher regardless of the compressor frequency.

Fan speed after defrost control: 990 rpm

4. Louver control

4-1. Individual louver control(For Compact cassette type)

To independently can be set the airflow pattern of each louver as follows:

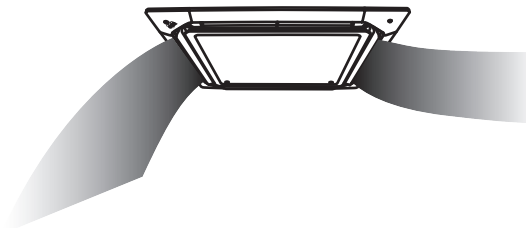

This function is given priority to overall louver control. But this function is release during the following operation.

- Cold air prevention control
- Monitor mode on the auto change over operation
- Defrost operation

The air direction range will change as follows:

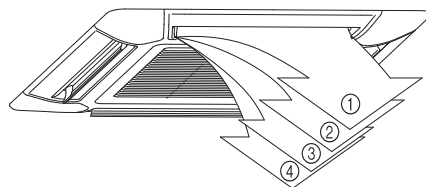

Use the wired remote controller to set this function. This function is only available by 2 wire remote controller.

NOTE: When the 2 wire remote controller is disconnected, clear the individual setting. Otherwise, this setting can't change.

4-2. All louver control(For Compact cassette type)

- **All louver operation**

When the mode is selected, the standard louver position of the each mode is set.

Operation mode	Standard Position
Cooling	1
Dry	1
Heating	4
Monitor	1

NOTES:

- Setting of the wireless remote controller is not displayed on the wired remote controller.
- The setting louver of the individual control function cannot be controlled.

4-3. Swing operation(For Compact cassette type)

- To select vertical airflow swing operation
When the swing signal is received, the vertical airflow direction louver starts to swing.
 - Swinging range
 - Cooling mode/dry mode/fan mode: 1 ↔ 4
 - Heating mode: 1 ↔ 4
 - When the indoor fan is S-LOW or stop mode, the swing operation is interrupted and it stops at either upper end or bottom end.

5. Timer operation control

5-1. Wireless remote control

On/Off timer	Program timer	Sleep timer	Weekly timer
○	○	○	—

■ On/Off timer

- Off timer: When the clock reaches the set timer, the air conditioner will be turned off.

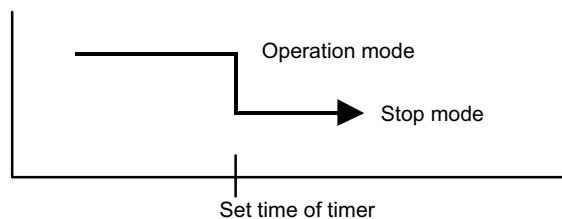

- On timer: When the clock reaches the set timer, the air conditioner will be turned on.

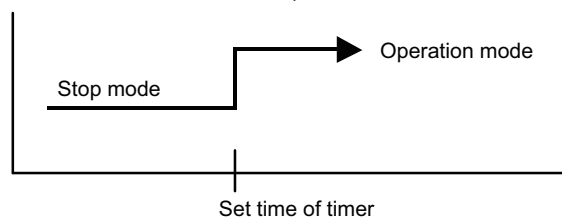

■ Program timer

- The program timer allows the off timer and the on timer to be used in combination one time.

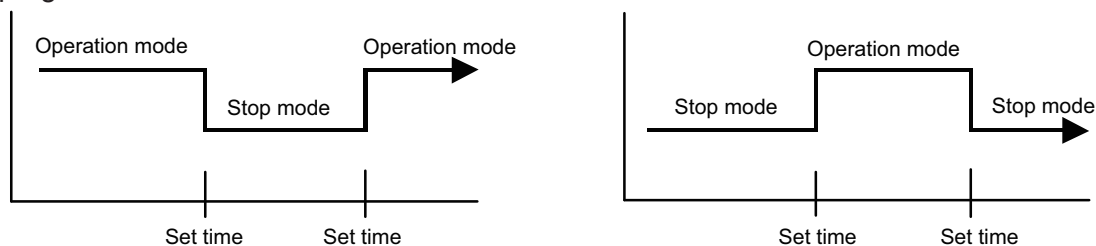

- Operation will start from the timer setting (either off timer and on timer) whichever is closest to the clock current timer setting. The order of operations is indicated by the allow in the remote controller screen.
- Sleep timer operation cannot be combined with on timer operation.

■ Sleep timer

If the sleep timer is set, the room temperature is monitored and the operation is stopped automatically. If the operation mode or the set temperature is change after the sleep timer is set, the operation is continued according to the changed setting of the sleep timer from that time on.

- In the cooling operation mode

When the sleep timer is set, the setting temperature is increased 1°C . It increases the setting temperature another 1°C after 1 hour. After that, the setting temperature is not changed and the operation is stopped at the setting time.

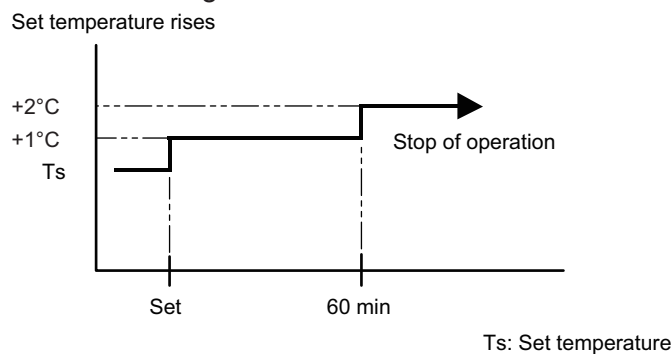

- In the heating operation mode

When the sleep timer is set, the setting temperature is decreased 1°C . It decreases the setting temperature another 1°C every 30 minutes. Upon lowering 4°C , the setting temperature is not changed and the operation is stopped at the setting time.

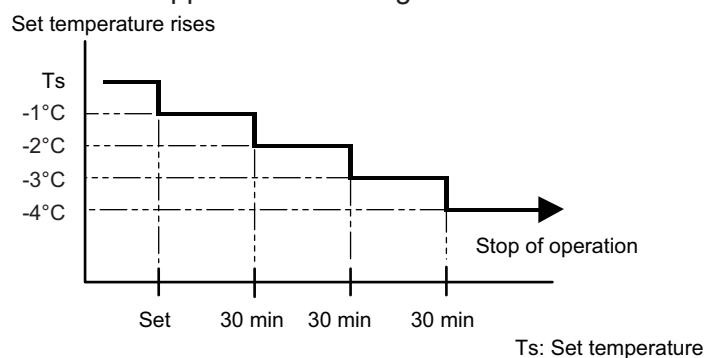

5-2. Wired remote control

On/Off timer	Program timer	Sleep timer	Weekly timer	Temperature set back timer
○	○	○	○	○

■ On/Off timer

- Off timer: When the clock reaches the set timer, the air conditioner will be turned off.

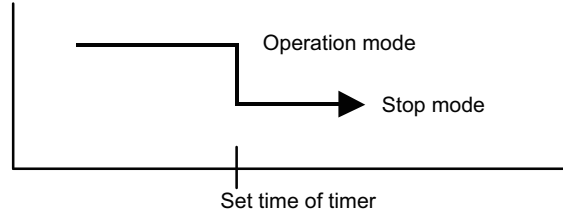

- On timer: When the clock reaches the set timer, the air conditioner will be turned on.

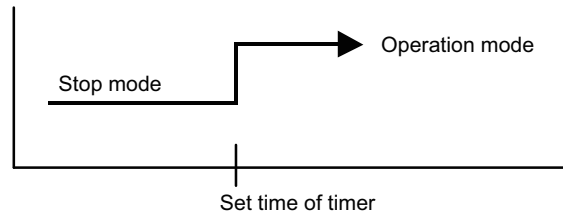

■ Program timer

- The program timer allows the off timer and the on timer to be used in combination one time.

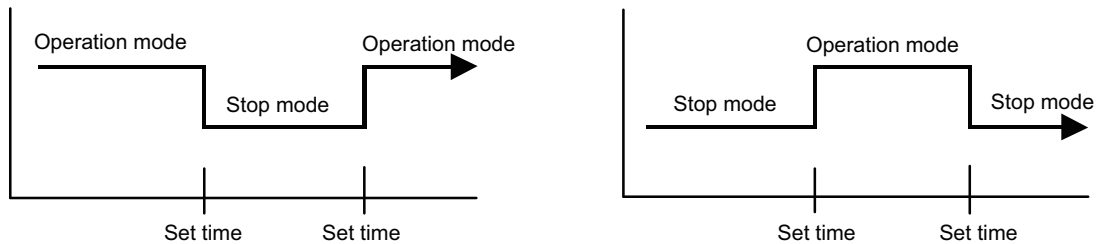

- Operation will start from the timer setting (either off timer and on timer) whichever is closest to the clock current timer setting. The order of operations is indicated by the allow in the remote controller screen.
- Sleep timer operation cannot be combined with on timer operation.

■ Sleep timer

If the sleep timer is set, the room temperature is monitored and the operation is stopped automatically. If the operation mode or the set temperature is change after the sleep timer is set, the operation is continued according to the changed setting of the sleep timer from that time on.

- In the cooling operation mode

When the sleep timer is set, the setting temperature is increased 1°C. It increases the setting temperature another 1°C after 1 hour. After that, the setting temperature is not changed and the operation is stopped at the setting time.

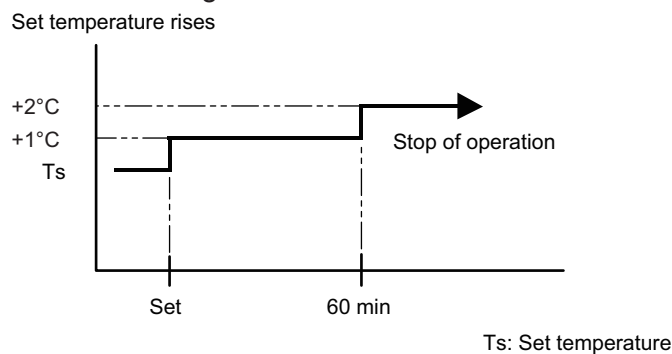

- In the heating operation mode

When the sleep timer is set, the setting temperature is decreased 1°C. It decreases the setting temperature another 1°C every 30 minutes. Upon lowering 4°C, the setting temperature is not changed and the operation is stopped at the setting time.

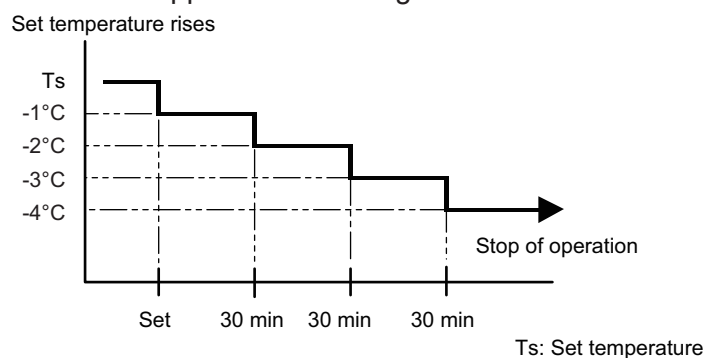

■ Weekly timer

On and off timer can be combined, and up to 4 reservations per day and 28 reservations per week. Before setting the program, set the week and time of the air conditioner at first. If the week and time are not set, the weekly timer will not operate correctly at the setting time.

■ Temperature set back timer

- The SET BACK timer only changes the set temperature for 7 days, it cannot be used to start or stop air conditioner operation.
- The SET BACK timer can be set to operate up to two times per day but only one temperature setting can be used.
- During COOLING/DRY mode, the air conditioner will operate at a minimum of 18°C even if the SET BACK temperature is set to 17°C or lower.

Case of SET BACK timer on the Cooling operation. (Setting temperature :22°C, SET BACK temperature :26°C)

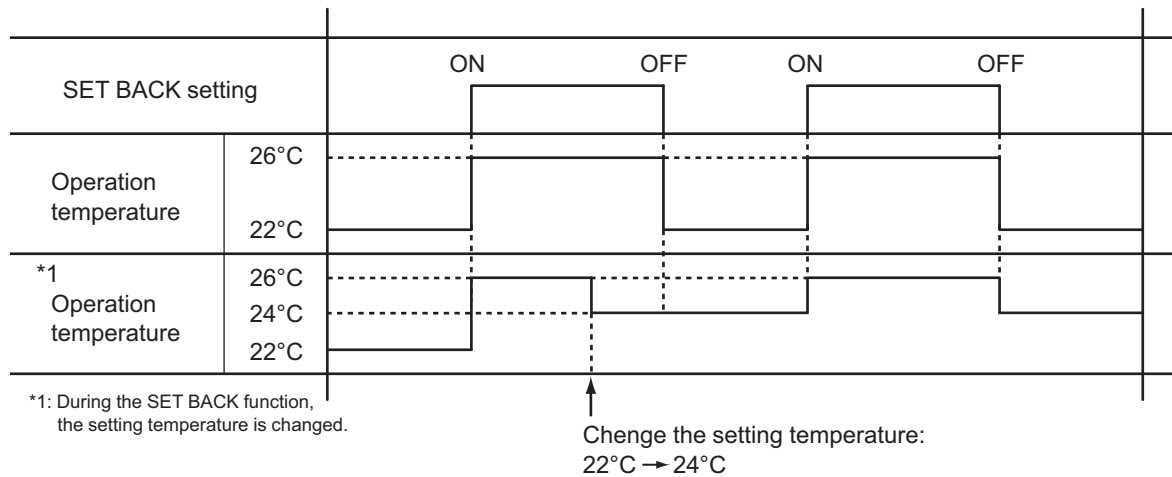

6. Defrost operation control

Tn: Outdoor unit heat exchanger temperature

Ta: Outdoor temperature

Tn10: Temperature at 10 minutes after compressor start

Tnb: Temperature before 5 minutes

• Triggering condition

The defrost operation starts when outdoor unit heat exchanger temperature sensor detects the temperature lower than the values shown below.

– 1st time defrosting after starting operation

Compressor integrating operation time	Less than 17 min.	17 to 57 min.	More than 57 min.
Condition	Does not operate	$T_n \leq -9^\circ\text{C}$ and $T_n - T_a \geq 5$ deg	$T_n \leq -5^\circ\text{C}$

– 2nd time and after

Compressor integrating operation time	Less than 35 min.	More than 35 min.
Condition	Does not operate	$T_n - T_{n10} < -5$ deg ($T_n \leq -10^\circ\text{C}$) $T_n - T_{nb} < -2$ deg ($T_n \leq -10^\circ\text{C}$) $T_n \leq -25^\circ\text{C}$ ($T_a \geq -20^\circ\text{C}$) $T_n \leq T_a - 7^\circ\text{C}$ or $T_n \leq -25^\circ\text{C}$ ($T_a < -20^\circ\text{C}$)

– Integrating defrost (Constant monitoring)

Compressor integrating operation time	More than 240 min. (For long continuous operation)	More than 215 min. (For long continuous operation)	Less than 10 min.* (For intermittent operation)
Condition	$T_n \leq -3^\circ\text{C}$	$T_n \leq -5^\circ\text{C}$	Count of the compressor off: 40 times

*: If the compressor continuous operation time is less than 10 minutes, the number of the compressor off is counted. If any defrost operated, the compressor off count is cleared.

• Release condition

The defrost operation is released when either one of the conditions below is satisfied.

Outdoor unit heat exchanger temperature (after 1 minute or later since compressor start)	12°C or more
Compressor operation time	15 minutes

6-1. Defrost operation in heating operation stopped

If the outdoor unit is frosted when stopping the heating operation, it stops after performing the automatic defrosting operation.

In this time, if the indoor unit operation lamp flashes slowly (6 sec on/2 sec off), the outdoor unit allow the heat exchanger to defrost, and then stop.

• Triggering condition

When all of the following conditions are satisfied in heating operation

- Compressor operation integrating time: 30 minutes or more
- Compressor continuous operation time: 10 minutes or more
- Outdoor unit heat exchanger temperature: -4°C or less

• Release condition

The defrost operation is released when either one of the conditions below is satisfied.

Outdoor unit heat exchanger temperature (after 1 minute or later since compressor start)	12°C or more
Compressor operation time	15 minutes

7. Various control

7-1. Auto restart

When the power was interrupted by a power failure etc. during operation, the operation contents at that time are memorized and when the power is recovered, operation is automatically started with the memorized operation contents.

Operation contents memorized when the power is interrupted	
Operation mode	
Setting temperature	
Fan mode setting	
Timer mode and set time (set by wireless remote controller)	
Airflow direction setting (For Compact cassette type)	
Swing (For Compact cassette type)	
ECONOMY operation	
10 °C HEAT operation	
Outdoor low noise operation	

7-2. 10 °C HEAT operation

10 °C HEAT operation performs as below setting when pressing 10 °C HEAT button.

Operation mode	Heating
Setting temperature	10°C
Fan mode	AUTO
LED display	Economy
Defrost operation	Operate as normal

7-3. ECONOMY operation

The ECONOMY operation starts by pressing ECONOMY button on the remote controller. The ECONOMY operation is almost the same operation as below settings.

Mode	Cooling/Dry	Heating
Target temperature	Setting temperature +1°C	Setting temperature -1°C

7-4. Fresh air control

The fan motor for Fresh Air is operated in synchronization with the indoor fan operation as below.

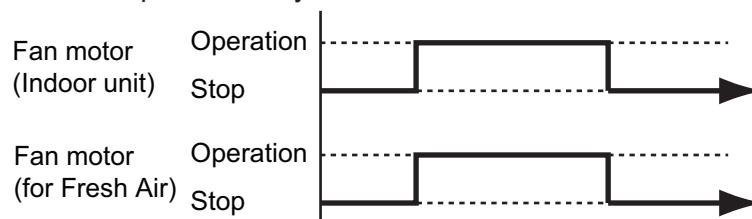

7-5. Compressor preheating

By preheating the compressor, warm airflow is quickly discharged when the operation is started.

- **Triggering condition 1**

- Outdoor temperature $\leq 20^{\circ}\text{C}$

When outdoor temperature reaches 26°C , compressor preheating stops.

- 30 minutes after compressor stopped

- **Triggering condition 2**

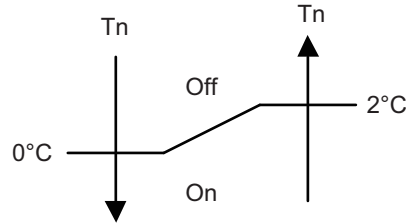

Tn: Outdoor unit heat exchanger temp.

7-6. External electrical heater control

The external electrical heater is operated as below.

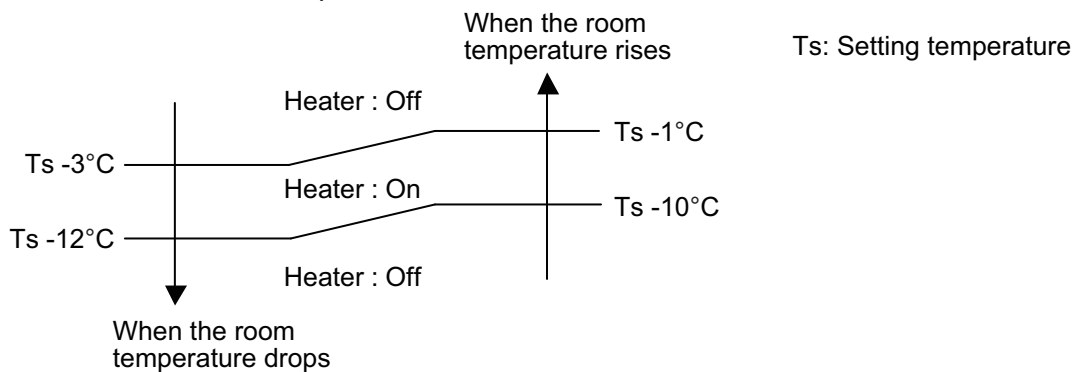

NOTES:

- When the compressor stop, external electric heater is off.
- It operates only in heating mode and when the indoor fan operates. (However, S-LOW is excluded.)

7-7. Electronic expansion valve control

The most proper opening of the electronic expansion valve is calculated and controlled under the present operating condition based on the table below.

Operation mode	Pulse range
Cooling/dry mode	Between 47 and 480 pulses
Heating mode	Between 39 and 480 pulses

NOTE: At the time of supplying the power to the outdoor unit, the initialization of the electronic expansion valve is operated (528 pulses are input to the closing direction).

7-8. Drain pump control

■ Drain control for dehumidification operation

● During cooling or dry mode

- On the main unit, when the compressor starts, the drain pump unit starts simultaneously. When the sub unit receives the signal from the main unit, the drain pump of the sub unit starts simultaneously.
- On the main unit, the drain pump operates continuously for 3 minutes after the compressor is turned off. When the sub unit receives the signal from the main unit, the drain pump of the sub unit operates continuously for 3 minutes after the compressor is turned off.

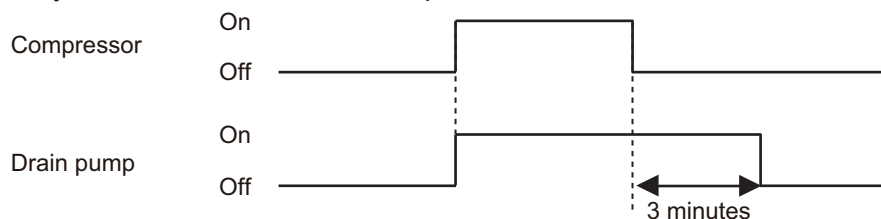

- When the compressor stops by the "Anti-freezing control (cooling and dry mode)" on page 04-34, the drain pump is turned off in 1 hour after the compressor stops.
- When the float switch is on, the compressor, indoor and outdoor fan motor operation are stopped. The sub unit sends the signal to the main unit simultaneously.
- When the float switch is turned off, the sub unit sends the signal to the main unit. Drain pump operates continuously for 3 minutes after the float switch is turned off and then drain pump is turned off.
- When the float switch turns on continuously for 3 minutes, "failure indication" operates. (It is necessary to turn off power for release it.)
- When the float switch turns off less than 3 minutes, the unit starts cooling operation. Indoor fan motor starts after the float switch is turned off and the compressor starts after 3 minutes st.

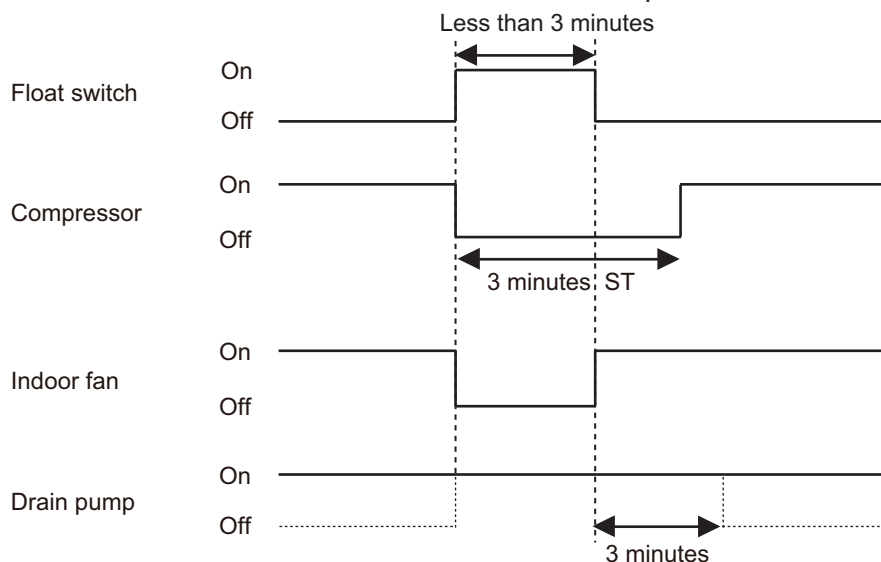

● During heating mode or fan mode and when operation is stopped

- **Triggering condition**

Drain pump is turned on at the same time that the float switch is turned on.

- **Operation details**

When the float switch turns on continuously for 3 minutes, "failure indication" operates. Thereafter, even if the float switch turns off, the "failure indication" is not released. (It is necessary to turn off power for release it.)

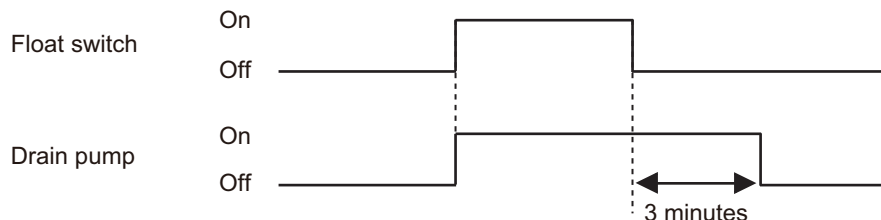

- **Release condition**

Drain pump operates continuously for 3 minutes after the float switch is turned off and then drain pump is turned off.

7-9. Prevention to restart for 3 minutes (3 minutes st)

When the compressor fails to start for the number of times below, it does not enter operation status for 3 minutes.

Retry number	30
Retry set number	3

When the compressor fails to start in the retry set number above, the compressor is stopped.

7-10. 4-way valve control

- If heating mode is selected at the compressor start, 4-way valve is energized for heating.
- When the air conditioner is switched between cooling and heating mode, compressor is stopped, and the 4-way valve is switched when the 3 minutes passes and the compressor is started.

7-11. Peak cut operation

The current value is limited to reduce the power consumption by external input.

Peak cut level	Level 1	Level 2	Level 3	Level 4
Peak cut for rated capacity	Forced thermostat off	50%	75%	100%

NOTES:

- During defrost operation, peak cut operation becomes invalid.
- Even during the peak cut operation, the operations of current overload, economy, and low noise are effective and the outdoor unit operates by lowest current of them.

7-12. Outdoor unit low noise operation

The compressor frequency and outdoor unit fan speed are limited to reduce the operation noise by external input.

Low noise mode	Low noise mode		Outdoor fan speed	Compressor frequency
			rpm	rps
AOYG36KRTA	Level 1	Cooling/Dry	830	44
		Heating		
	Level 2	Cooling/Dry	830	36
		Heating		
AOYG45KRTA AOYG54KRTA	Level 1	Cooling/Dry	740	60
		Heating		
	Level 2	Cooling/Dry	740	40
		Heating		

NOTES:

- During the defrost operation, the compressor operates by the speed for defrost operation.
- Even during the low noise operation, the operations of current overload, economy, and peak cut are effective and the outdoor unit operates by lowest current of them.

Capacity priority mode

- Operation condition
The function setting is set to 1.
- Capacity check condition
 - Shortage: Compressor frequency > limited compressor frequency for low noise mode
 - Enough: Compressor frequency ≤ limited compressor frequency for low noise mode
- Operation
When detecting the shortage capacity or enough capacity condition continuous 30 minutes, the mode is changed as follows:

- Automatic switching 1 (Level 1 setting)

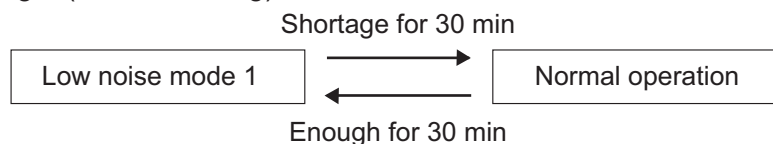

- Automatic switching 2 (Level 2 setting)

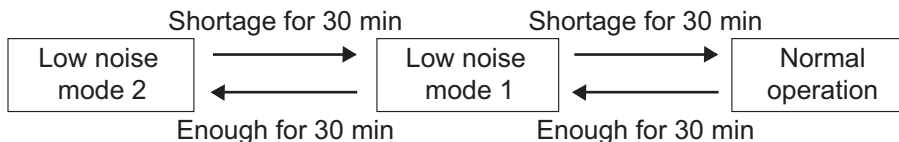

8. Various protections

8-1. Discharge gas temperature over-rise prevention control

The discharge gas temperature sensor (discharge thermistor: outdoor unit side) detects the discharge gas temperature.

- When the discharge temperature becomes higher than the trigger condition, the compressor frequency is decreased as the table below, and it continues to decrease until the discharge temperature becomes lower than the trigger condition.
- When the discharge temperature becomes lower than the release condition, control of compressor frequency is released.
- When the discharge temperature becomes higher than the compressor protection temperature, the compressor is stopped and the indoor unit LED starts blinking.

Trigger condition	104°C
Compressor frequency	-14 rps/120 seconds
Release condition	101°C
Compressor protection temperature	110°C

8-2. Anti-freezing control (cooling and dry mode)

The compressor frequency is decrease in cooling and dry mode when the indoor unit heat exchanger temperature sensor detects the temperature lower than the trigger condition.

When the indoor unit heat exchanger temperature reaches release condition, the anti-freezing control is stopped.

• Main unit

Trigger condition	4°C	
Release condition	Outdoor temp. $\geq 10^{\circ}\text{C}^{*1}$	7°C
	Outdoor temp. $\geq 12^{\circ}\text{C}^{*2}$	
	Outdoor temp. $< 10^{\circ}\text{C}^{*1}$	13°C
	Outdoor temp. $< 12^{\circ}\text{C}^{*2}$	

*1: During the outdoor temperature dropping

*2: During the outdoor temperature rising

• Sub unit

Trigger condition	2°C (When continues for 7 minutes)
Release condition	13°C (3 minutes after since compressor stopped)

8-3. Current release control

The compressor frequency is controlled so that the outdoor unit input current does not exceed current limit value set according to the outdoor temperature.

The compressor frequency returns according to the operation mode, when the current becomes lower than the release value.

■ Model: AOYG36KRTA

Operation mode	Outdoor temp. (Ta)	Trigger condition	Release condition
Cooling	$52^{\circ}\text{C} \leq \text{Ta}$	3.5 A	3.0 A
	$50^{\circ}\text{C} \leq \text{Ta} < 52^{\circ}\text{C}$	5.5 A	5.0 A
	$42^{\circ}\text{C} \leq \text{Ta} < 50^{\circ}\text{C}$	6.0 A	5.5 A
	$2^{\circ}\text{C} \leq \text{Ta} < 42^{\circ}\text{C}$	7.5 A	7.0 A
	$\text{Ta} < 2^{\circ}\text{C}$	8.5 A	8.0 A
Heating	$20^{\circ}\text{C} \leq \text{Ta}$	5.5 A	5.0 A
	$16^{\circ}\text{C} \leq \text{Ta} < 20^{\circ}\text{C}$	6.0 A	5.5 A
	$12^{\circ}\text{C} \leq \text{Ta} < 16^{\circ}\text{C}$	7.0 A	6.5 A
	$2^{\circ}\text{C} \leq \text{Ta} < 12^{\circ}\text{C}$	7.5 A	7.0 A
	$\text{Ta} < 2^{\circ}\text{C}$	8.5 A	8.0 A

■ Models: AOYG45KRTA and AOYG54KRTA

Operation mode	Outdoor temp. (Ta)	Trigger condition	Release condition
Cooling	$52^{\circ}\text{C} \leq \text{Ta}$	4.5 A	4.0 A
	$50^{\circ}\text{C} \leq \text{Ta} < 52^{\circ}\text{C}$	5.5 A	5.0 A
	$46^{\circ}\text{C} \leq \text{Ta} < 50^{\circ}\text{C}$	6.5 A	6.0 A
	$42^{\circ}\text{C} \leq \text{Ta} < 46^{\circ}\text{C}$	7.5 A	7.0 A
	$2^{\circ}\text{C} \leq \text{Ta} < 42^{\circ}\text{C}$	8.5 A	8.0 A
	$\text{Ta} < 2^{\circ}\text{C}$	10.0 A	9.5 A
Heating	$20^{\circ}\text{C} \leq \text{Ta}$	6.5 A	6.0 A
	$16^{\circ}\text{C} \leq \text{Ta} < 20^{\circ}\text{C}$	7.0 A	6.5 A
	$12^{\circ}\text{C} \leq \text{Ta} < 16^{\circ}\text{C}$	8.0 A	7.5 A
	$2^{\circ}\text{C} \leq \text{Ta} < 12^{\circ}\text{C}$	8.5 A	8.0 A
	$\text{Ta} < 2^{\circ}\text{C}$	10.0 A	9.5 A

8-4. Low pressure protection control (cooling mode)

- After the compressor start-up and 10 minutes has passed**
 When the pressure sensor detected value is 0.68MPaG or less continues for 1minute, the compressor frequency -8rps.
- After the frequency of the compressor -8rps and 1 minute has passed**
 When the pressure sensor detected value is 0.68MPaG or less, continues for 1 minute, the compressor continues frequency -8rps every 1 minute until the detected value becomes more than 0.68MPaG.
 When the detected value becomes more than 0.78MPaG, this protection is released.
- After the compressor start-up and 1 minute has passed**
 The detected value of pressure sensor is 0.02MPaG or less, continues for 5 minutes, the compressor is stopped.

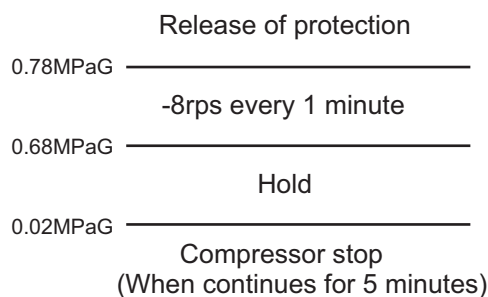

8-5. Indoor unit fan motor over temperature protection

■ Compact cassette type

When satisfy the following conditions, the protection works.

- After the 90 seconds from the fan operation, detect less than 300 rpm for 10 seconds.
- IPM trip protection works.
- Current overload protection works.

When detecting the above condition, recheck the condition after 6 minutes. When count the twice, the protection works.

• Protection contents

Reduce the static pressure 20 Pa. When it does not dissolve even the minimum static pressure condition, work the following operation.

- Fan motor error displayed when less than 300 rpm for 10 seconds is detected after the 90 seconds from the fan operation.
- Fan stop 40 seconds when IPM trip protection works.
- Fan stop 50 seconds when current overload protection works.

■ Slim duct and Medium static pressure duct types

When satisfy the following conditions, the protection works.

- After the 90 seconds from the fan operation, detect less than 200 rpm for 10 seconds.
- IPM trip protection works.
- Current overload protection works.

When detecting the above condition, recheck the condition after 6 minutes. When count the twice, the protection works.

• Protection contents

Reduce the static pressure 20 Pa. When it does not dissolve even the minimum static pressure condition, work the following operation.

- Fan motor error displayed when less than 200 rpm for 10 seconds is detected after the 90 seconds from the fan operation.
- Fan stop 40 seconds when IPM trip protection works.
- Fan stop 50 seconds when current overload protection works.

8-6. Compressor temperature protection

When the compressor temperature sensor detects higher than the trigger condition below, the compressor is stopped. When the compressor temperature sensor detects the release condition, the protection is released.

Trigger condition	108°C
Release condition	80°C (3 minutes after compressor stop)

8-7. High pressure protection

Trigger condition	Pressure switch: Off (Open: Higher than 4.2 MPa) Compressor stop
Release condition	Pressure switch: On (Close: Lower than 3.2 MPa) (3 minutes after compressor stop) Compressor restart

8-8. Low outdoor temperature protection

When the outdoor temperature sensor detects lower than the trigger condition below, the compressor is stopped.

Operation mode	Cooling/Dry	Heating
Trigger condition		-20°C
Release condition		-15°C

8-9. High temperature and high pressure release control

The compressor is controlled as follows.

■ Models: AOYG36KRTA, AOYG45KRTA, and AOYG54KRTA

• Heating mode

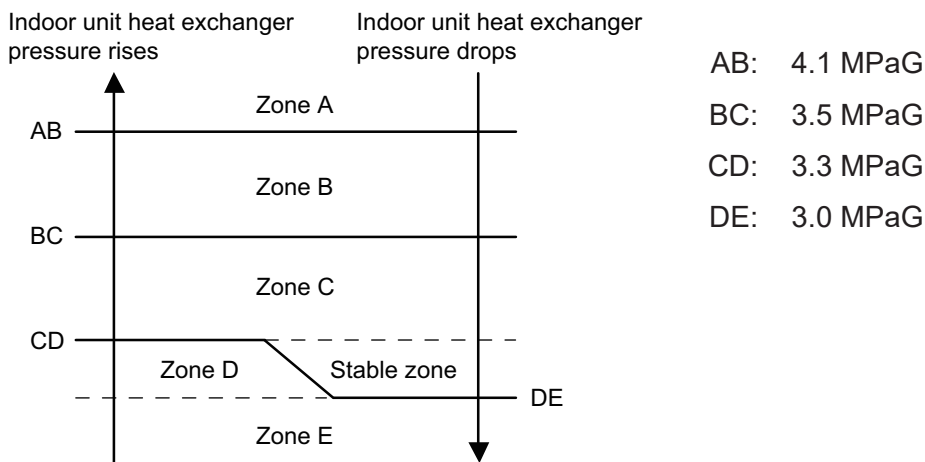

Zone	Operation	
Zone A	Compressor is stopped.	
Zone B	The compressor frequency is decreased.	-10 rps/120 sec.
Zone C		-2 rps/120 sec.
Zone D	The protection is released and the operation is returned to normal mode.	
Zone E		

5. FILED WORKING

CONTENTS

5. FILED WORKING

1. Function settings	05-1
1-1. Outdoor unit.....	05-1
1-2. Compact cassette type (setting by DIP switch).....	05-5
1-3. Slim duct type (setting by DIP switch).....	05-7
1-4. Duct type (setting by DIP switch).....	05-9
1-5. Indoor unit (setting by wireless remote controller)	05-11
1-6. Indoor unit (setting by wired remote controller).....	05-17
1-7. Indoor unit (setting by simple remote controller).....	05-23
1-8. Function details	05-27
1-9. Wired remote controller (UTY-RNNYM)	05-33
1-10. Wired remote controller (UTY-RVNYM).....	05-35
1-11. Simple remote controller (UTY-RSNYM)	05-36

1. Function settings

To adjust the functions of this product according to the installation environment, various types of function settings are available.

NOTE: Incorrect settings can cause a product malfunction.

1-1. Outdoor unit

■ Control PCB and switch buttons location

Control PCB of the outdoor unit is located as shown in the following figure.

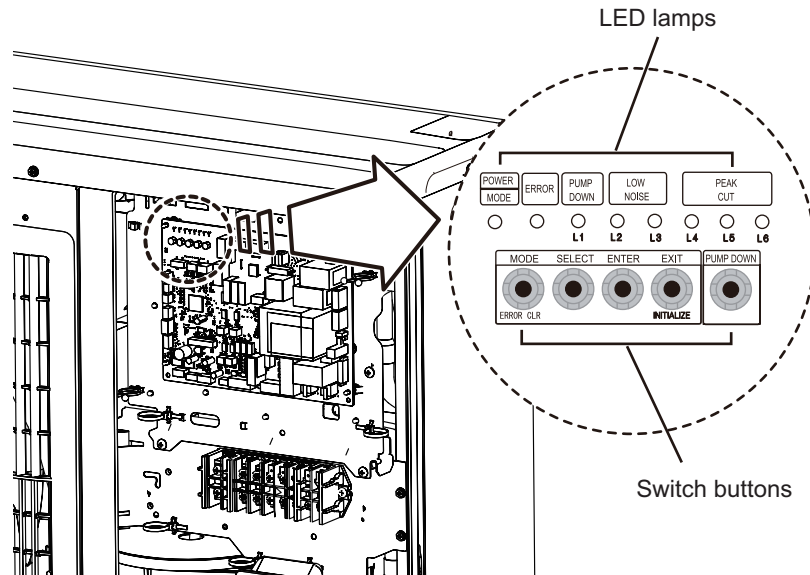

● Switch buttons and the functions

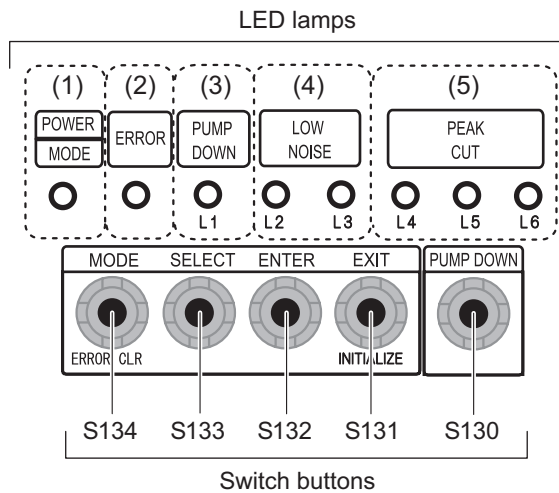

LED lamp		Function or operation method	
(1)	POWER/MODE	Green	Lights on while power on. Local setting in outdoor unit or error code is displayed with blink.
(2)	ERROR	Red	Blinks during error operation.
(3)	PUMP DOWN (L1)	Orange	Lights on during pump down operation.
(4)	LOW NOISE MODE (L2 and L3)	Orange	Lights on during "Low noise mode" when local setting is activated. (Lighting pattern of L2 and L3 indicates low noise level.)
(5)	PEAK CUT MODE (L4, L5, and L6)	Orange	Lights on during "Peak cut mode" when local setting is activated. (Lighting pattern of L4, L5, and L6 indicates peak cut level.)

Switch button		Function or operation method
S134	MODE	Switches between "Local setting" and "Error code display".
S133	SELECT	Switches between the individual "Local settings" and the "Error code displays".
S132	ENTER	Switches between the individual "Local settings" and the "Error code displays".
S131	EXIT	Returns to "Operation status display".
S130	PUMP DOWN	Starts the pump down operation.

● Function setting table

No.	Setting item		LED display								Factory setting
			POWER MODE	ERROR	PUMP DOWN	LOW NOISE			PEAK CUT		
						(L1)	(L2)	(L3)	(L4)	(L5)	
1	Low noise mode setting	Level 1	Blink (9 times)	○	○	○	●	○	○	●	◆
		Level 2		○	○	○	●	○	●	○	
2	Peak cut mode setting	Level 1		○	○	●	○	○	○	●	○
		Level 2		○	○	●	○	○	●	○	○
		Level 3		○	○	●	○	○	●	●	○
		Level 4		○	○	●	○	●	○	○	○

Sign "○": Lights off, "●": Lights on

No.	Setting item	Content
1	Low noise mode setting	By using the "Low noise mode", the limit of the noise level will be set to decrease the noise level. The mode comes in 2 levels which can be set accordingly. To turn on the mode, use the external input terminal (P580). <ul style="list-style-type: none"> By using this mode, the cooling/heating performance may decrease. Depending on the operating condition, the noise level may not decrease even if the Low noise mode is on.
2	Peak cut mode setting	The capacity limit can be selected when operating with the "Peak cut mode." The operation selection can be done by external input terminal (PA580). The lower the level, the more the effect of energy saving, but the cooling/heating performance decreases.

Local setting procedure

NOTE: Before performing the function setting, be sure to stop the operation of the air conditioner.

Low noise mode

1. Press the MODE switch button (S134) for 3 seconds or more to switch to “Local setting mode”.
2. After confirming the LED lamp of POWER/MODE blinks 9 times, press the ENTER switch button (S132).

POWER MODE	ERROR	PUMP DOWN (L1)	LOW NOISE		PEAK CUT		
			(L2)	(L3)	(L4)	(L5)	(L6)
Blinks (9 times)	○	○	○	○	○	○	○

Sign “○”: Lights off

3. Press the SELECT switch button (S133), and adjust the LED lamp as shown below. Then the LED lamp indicates the current setting.

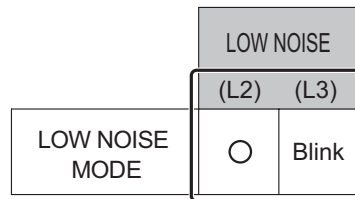

4. Press the ENTER switch button (S132).

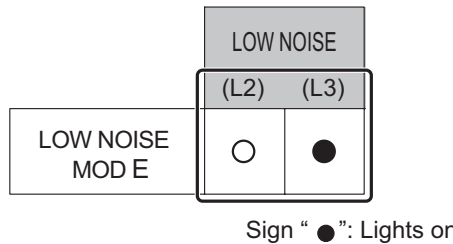

5. Press the SELECT switch button (S133), and adjust the LED lamps as shown below.



6. Press the ENTER switch button (S132) and fix it.

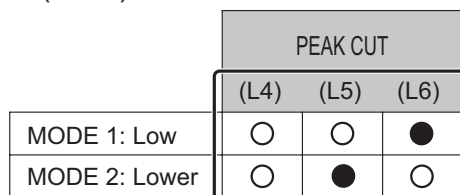

7. To return to “Operating status display (Normal operation)”, press the EXIT switch button (S131).

In case of missing how many times you pressed the SELECT and ENTER switch buttons:

1. To return to “Operation status display (Normal operation)”, press the EXIT switch button once.
2. Restart from the beginning of setting procedure.

NOTE: In case of missing how many times you pressed the SELECT and ENTER switch buttons, you must redo the setting procedure. Return to “Operation status display (Normal operation)” by pressing the EXIT switch button once, and restart from the beginning of the setting procedure.

● Peak cut mode

1. Press the MODE switch button (S134) for 3 seconds or more to switch to “Local setting mode”.
2. After confirming the LED lamp of POWER/MODE blinks 9 times, press the ENTER switch button (S132).

POWER MODE	ERROR	PUMP DOWN (L1)	LOW NOISE (L2) (L3)		PEAK CUT (L4) (L5) (L6)		
Blinks (9 times)	○	○	○	○	○	○	○

Sign “○”: Lights off

3. Press the SELECT switch button (S133), and adjust the LED lamp as shown below. Then the LED lamp indicates the current setting.

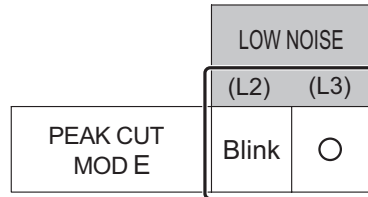

4. Press the ENTER switch button (S132).

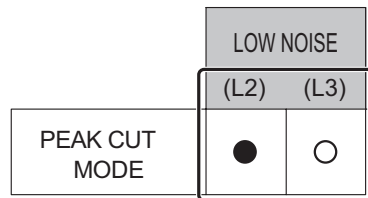

Sign “●”: Lights on

5. Press the SELECT switch button (S133), and adjust the LED lamps as shown below.

	PEAK CUT		
	(L4)	(L5)	(L6)
0 % of rated input ratio	○	○	Blink
50 % of rated input ratio	○	Blink	○
75 % of rated input ratio	○	Blink	Blink
100 % of rated input ratio	Blink	○	○

6. Press the ENTER switch button (S132) and fix it.

	PEAK CUT		
	(L4)	(L5)	(L6)
0 % of rated input ratio	○	○	●
50 % of rated input ratio	○	●	○
75 % of rated input ratio	○	●	●
100 % of rated input ratio	●	○	○

7. To return to “Operating status display (Normal operation)”, press the EXIT switch button (S131).

NOTE: When pressed number is lost during setting, you must redo the setting procedure. Return to “Operation status display (Normal operation)” by pressing the EXIT switch button once, and restart from the beginning of the setting procedure.

1-2. Compact cassette type (setting by DIP switch)

By using some components on the PCB, you can change the function settings.

■ Component location

Components on the indoor unit main PCB used for the function settings are located as shown in the following figure.

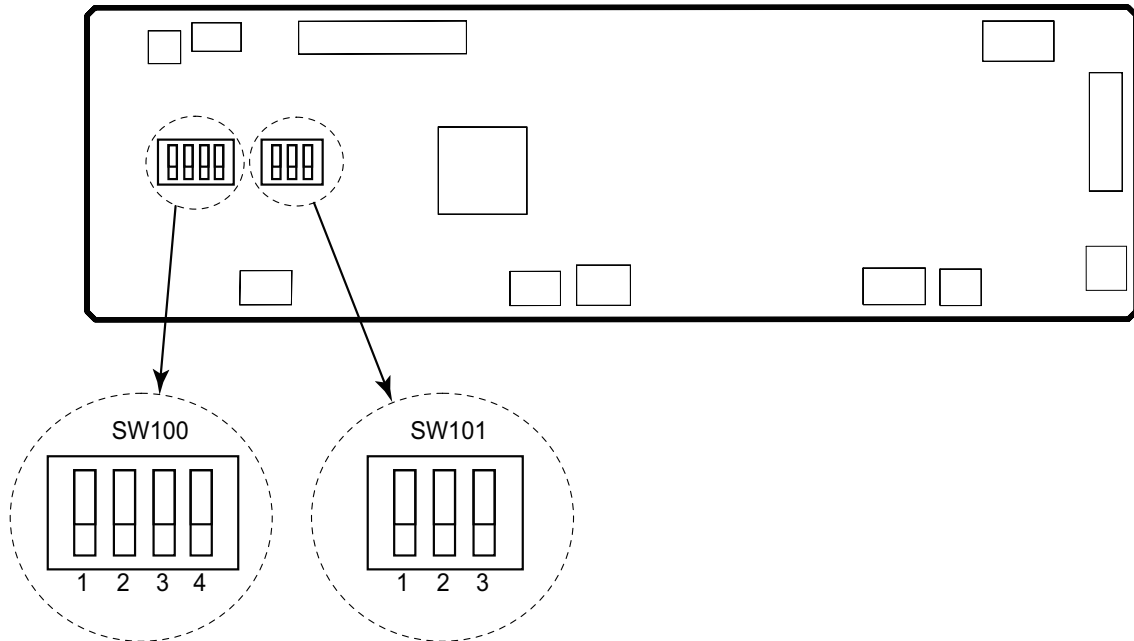

■ DIP switch setting

• SW100: Remote controller address setting

NOTE: Because this setting is normally done automatically when 2-core wired remote controller is installed, setting is unnecessary.

Multiple indoor units can be operated by using one wired remote controller.

Set the unit number of each indoor unit.

Remote controller address	DIP switch number				Factory setting
	1	2	3	4	
00	OFF	OFF	OFF	OFF	◆
01	ON	OFF	OFF	OFF	
02	OFF	ON	OFF	OFF	
03	ON	ON	OFF	OFF	
04	OFF	OFF	ON	OFF	
05	ON	OFF	ON	OFF	
06	OFF	ON	ON	OFF	
07	ON	ON	ON	OFF	
08	OFF	OFF	OFF	ON	
09	ON	OFF	OFF	ON	
10	OFF	ON	OFF	ON	
11	ON	ON	OFF	ON	
12	OFF	OFF	ON	ON	
13	ON	OFF	ON	ON	
14	OFF	ON	ON	ON	
15	ON	ON	ON	ON	

NOTES:

- When connecting Polar 3-core wired remote controller, set the remote controller address in the order of 0, 1, 2,, and 15.
- When different type of indoor units (such as wall-mounted type and cassette type, cassette type and duct type, or other combinations) are connected using group control system, some functions may no longer be available.

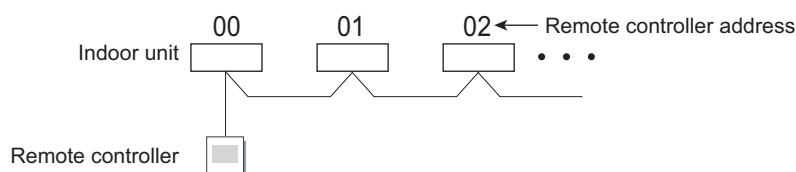

• SW101: Setting change prohibited

1-3. Slim duct type (setting by DIP switch)

By using some components on the PCB, you can change the function settings.

Related components on the PCB and the applicable settings:

Component			Setting content
DIP switch	SW100	1	Remote controller address setting
		2	
		3	
		4	
	SW101	1	Drainage function setting
		2	Auto louver grille setting
		3	Fan delay setting

■ Component location

Components on the indoor unit main PCB used for the function settings are located as shown in the following figure.

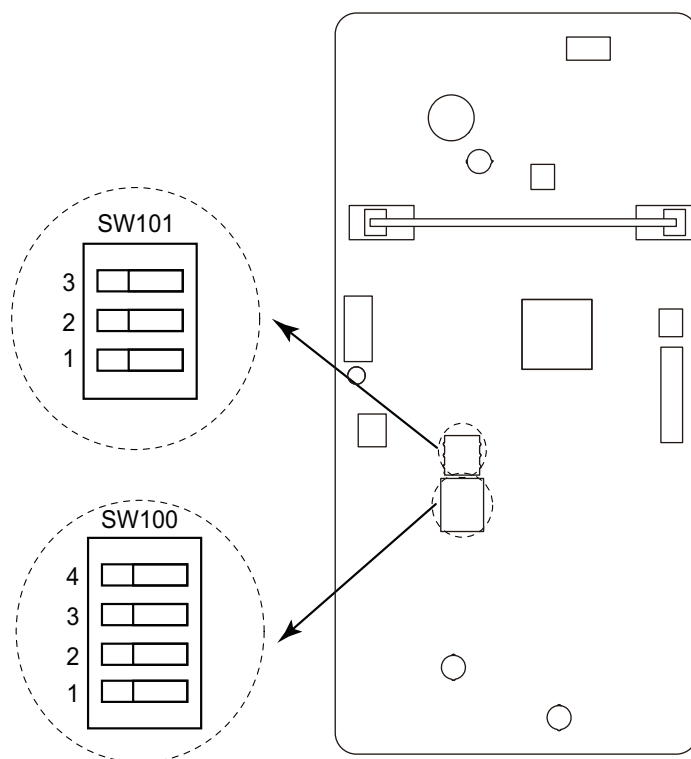

■ DIP switch setting

- **SW100: Remote controller address setting**

When operating a number of indoor units by using a wired remote controller, DIP switch setting for assigning unit number to each indoor unit is required.

The slide switches are normally set to make the unit number 00.

Remote controller address	Switch number				Factory setting
	1	2	3	4	
00	OFF	OFF	OFF	OFF	◆
01	ON	OFF	OFF	OFF	
02	OFF	ON	OFF	OFF	
03	ON	ON	OFF	OFF	
04	OFF	OFF	ON	OFF	
05	ON	OFF	ON	OFF	
06	OFF	ON	ON	OFF	
07	ON	ON	ON	OFF	
08	OFF	OFF	OFF	ON	
09	ON	OFF	OFF	ON	
10	OFF	ON	OFF	ON	
11	ON	ON	OFF	ON	
12	OFF	OFF	ON	ON	
13	ON	OFF	ON	ON	
14	OFF	ON	ON	ON	
15	ON	ON	ON	ON	

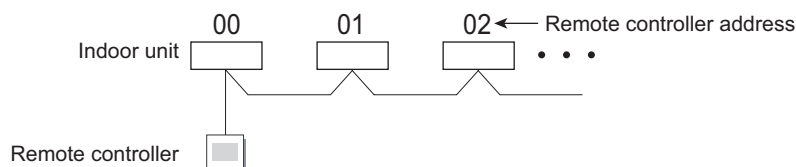

- **SW101-Switch 1: Drainage function setting**

Switch 1	Drainage function	Factory setting
ON	Disabled	
OFF	Enabled	◆

- **SW101-Switch 2: Auto louver grille setting**

When Auto louver grille kit (optional parts) is attached, set to "Enabled".

Switch 2	Auto louver grille setting	Factory setting
ON	Enabled	
OFF	Disabled	◆

- **SW101-Switch 3: Fan delay setting**

When the indoor unit is stopped while operating in conjunction with auxiliary heater, the indoor unit fan operation will continue for 1 minute.

Switch 3	Fan delay	Factory setting
ON	Enabled	
OFF	Disabled	◆

1-4. Duct type (setting by DIP switch)

By using some components on the PCB, you can change the function settings.

Related components on the PCB and the applicable settings:

Component		Setting content	
DIP switch	SW100	1	Remote controller address setting
		2	
		3	
		4	
	SW101	1	Setting change prohibited
		2	Setting change prohibited
		3	Fan delay setting

■ Component location

Components on the indoor unit main PCB used for the function settings are located as shown in the following figure.

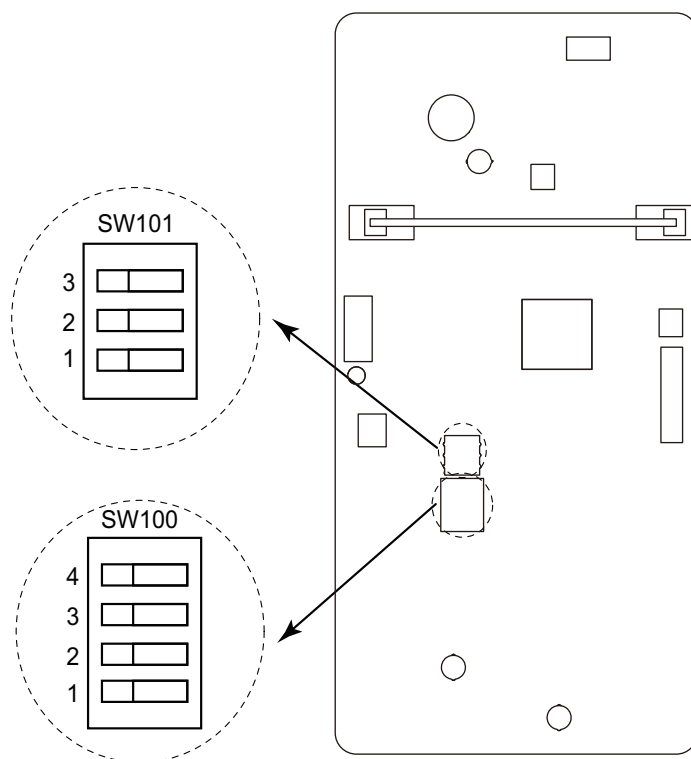

■ DIP switch setting

- **SW100: Remote controller address setting**

When operating a number of indoor units by using a wired remote controller, DIP switch setting for assigning unit number to each indoor unit is required.

The slide switches are normally set to make the unit number 00.

Remote controller address	Switch number				Factory setting
	1	2	3	4	
00	OFF	OFF	OFF	OFF	◆
01	ON	OFF	OFF	OFF	
02	OFF	ON	OFF	OFF	
03	ON	ON	OFF	OFF	
04	OFF	OFF	ON	OFF	
05	ON	OFF	ON	OFF	
06	OFF	ON	ON	OFF	
07	ON	ON	ON	OFF	
08	OFF	OFF	OFF	ON	
09	ON	OFF	OFF	ON	
10	OFF	ON	OFF	ON	
11	ON	ON	OFF	ON	
12	OFF	OFF	ON	ON	
13	ON	OFF	ON	ON	
14	OFF	ON	ON	ON	
15	ON	ON	ON	ON	

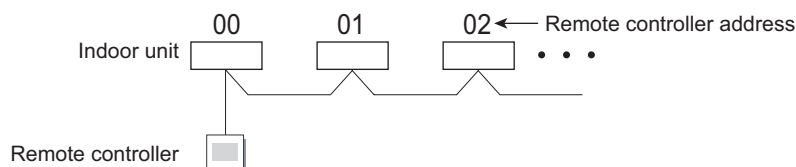

- **SW101-Switch 1: Setting change prohibited**

- **SW101-Switch 2: Setting change prohibited**

- **SW101-Switch 3: Fan delay setting**

When the indoor unit is stopped while operating in conjunction with auxiliary heater, the indoor unit fan operation will continue for 1 minute.

Switch 3	Fan delay	Factory setting
ON	Enabled	
OFF	Disabled	◆

1-5. Indoor unit (setting by wireless remote controller)

⚠ CAUTION

This setting changes the function settings used to control the indoor unit according to the installation conditions. Incorrect settings can cause a product malfunction.

- After the power is turned on, perform the “Function setting” according to the installation conditions using the remote controller.
- The settings may be selected between the following two: Function number or Setting number.
- Settings will not be changed if invalid numbers or setting numbers are selected.

■ Preparation

Before connecting the power supply of the indoor unit, reconfirm following items:

- Piping air tight test and vacuuming have been performed firmly.
- There is no wiring mistake. Then, connect the power supply of the indoor unit.

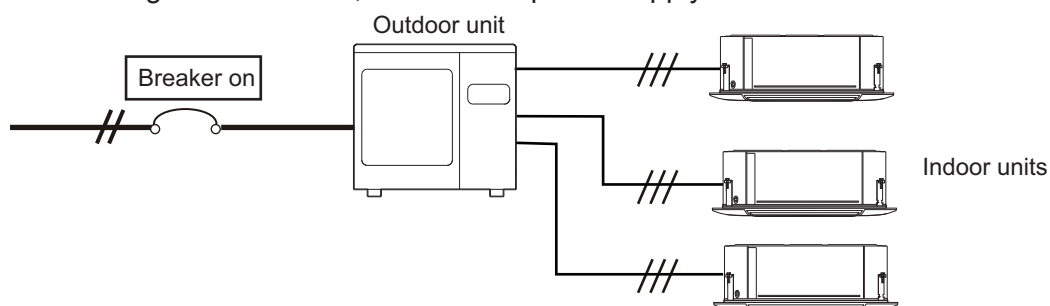

■ UTY-LNTY (included in UTY-LBTYM)

● Button name and function

During address setting mode, indoor unit reject the any operation command from remote controller.

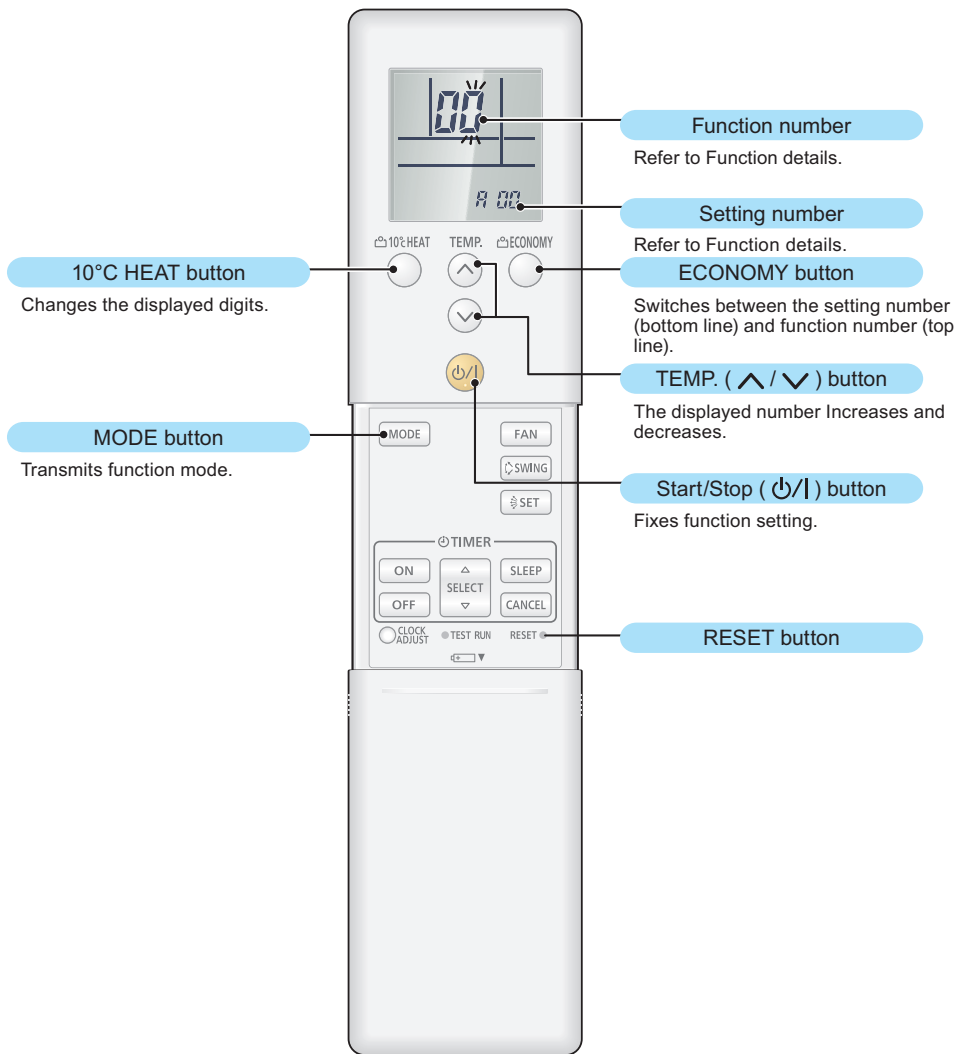

● Function setting procedure

1. Connect the power supply of the outdoor unit.
2. To enter the function setting mode, while holding down the ECONOMY and SET TEMP. ^ buttons, press the RESET button.

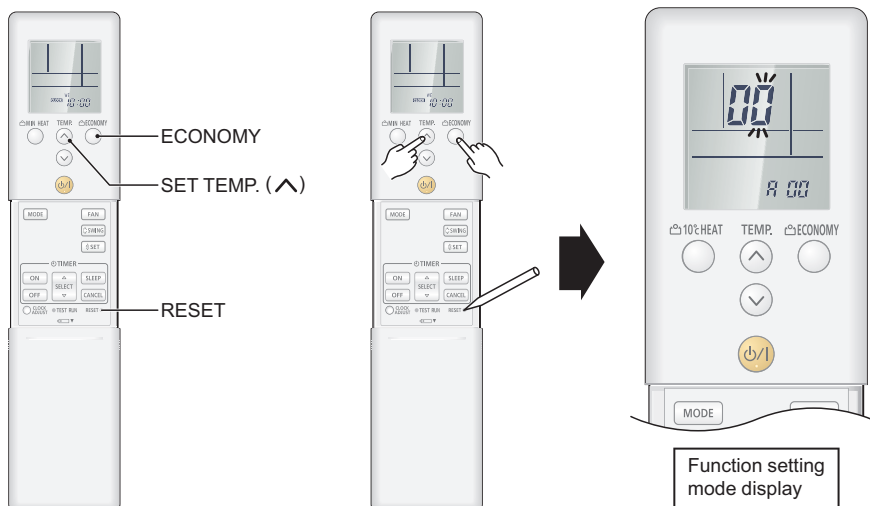

3. Select the function number by pressing the \wedge or the \vee buttons. Each time the 10°C HEAT button is pressed, it switches between the right digit and the left digit.



4. Proceed to the setting number by pressing the ECONOMY button. (To return to the function number selection, press the ECONOMY button again.)



5. Select the function number by pressing the \wedge or the \vee button. Each time the 10°C HEAT button is pressed, it switches between the right digit and the left digit.

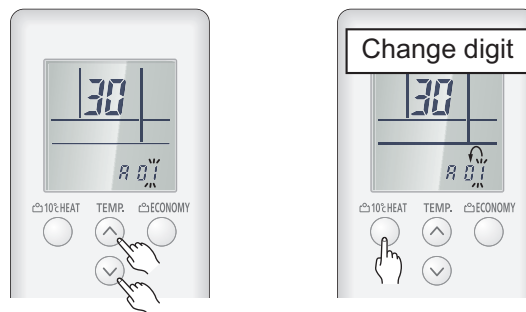

6. Press the MODE button once to transmit the function mode information.

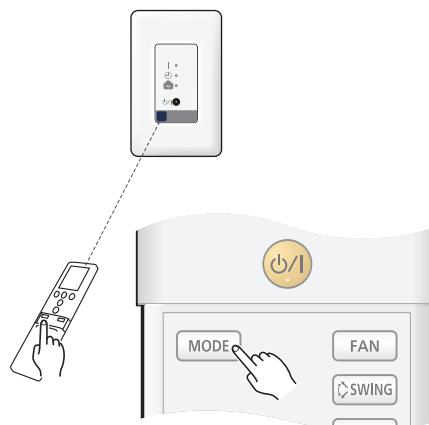

FIELD WORKING

FIELD WORKING

7. Press the $\phi/|$ button once to transmit the function setting information. 1 short beep will be emitted from the indoor unit or the IR receiver when the signal is received correctly. If wrong code is set, no beep sound will be emitted.

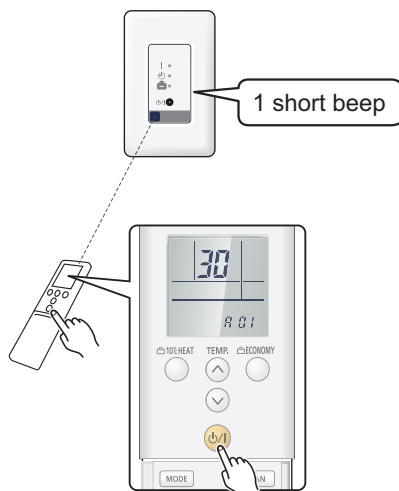

NOTE: Press $\phi/|$ button within 30 seconds after pressing MODE button.

For the function details, refer to [Chapter 1-8. "Function details"](#) on page 05-27.

8. Exit the function setting mode by pressing the RESET button.

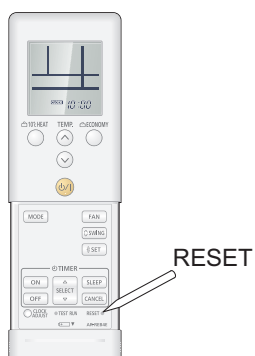

● Setting up each indoor unit

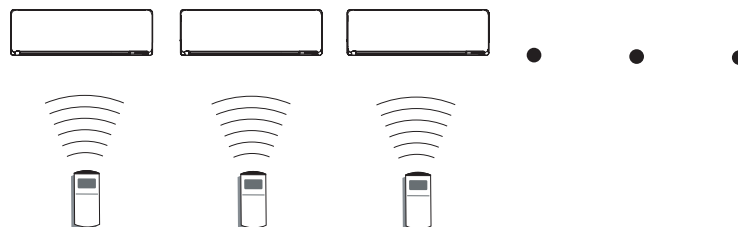

Repeat step from 1. to 8. to set up each indoor unit. If the custom code is other than "H", steps from 1. to 2. and 8. need to be performed.

● Resetting the power after setting up all indoor units

Important:

- If the reset is not performed, function cannot be read correctly.
- After all the functions have been set, the circuit breaker needs to be switched off for at least 2 minutes.
 - After the 2 minutes has passed, power can be restored.
 - The set function is stored in the PCB and will remain in memory even when the power of indoor unit is turned off. However setting function is effective after disconnecting the power supply and then reconnecting it.
- Record the latest configuration of the indoor unit function setting on a label, and put the label on the unit so it can be used for after-sales service operations.

Once the RESET button is pressed on the remote controller, the operation mode will be set to the AUTO MODE.

Adjust the operation mode to either cooling or heating before starting the operation of the air conditioner.

NOTE: If custom code other than "H" is set, the remote control must be set accordingly to the indoor unit setting.

● Remote controller custom code setting

Custom code setting of wireless remote controller needs to be same as the setting of the indoor unit. When you change the custom code setting of the wireless remote controller, do as follows:

1. Press the START/STOP button until only the clock is displayed on the display.

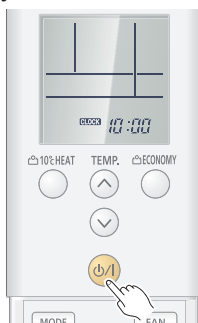

2. Press the MODE button for at least 5 seconds to display the current custom code (initially set to A).
3. Press the SET TEMP. “ ^ ” or the “ v ” button to change the custom code between A → B → C → D.

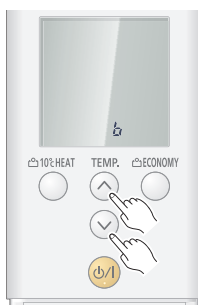

4. Press the MODE button again to return to the clock display. The custom code will be changed.

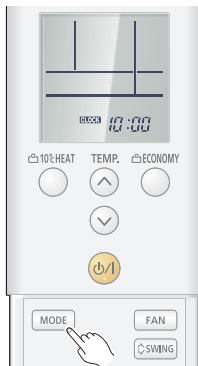

- If no buttons are pressed within 30 seconds after the custom code is displayed, the system returns to the original clock display. In this case, start again from step 1.
- The air conditioner custom code is set to A prior to shipment.
- If you do not know the air conditioner custom code setting, try each of the custom codes (A → B → C → D) until you find the code which operates the air conditioner.

1-6. Indoor unit (setting by wired remote controller)

- The function settings of the control of the indoor unit can be changed by this procedure according to the installation conditions. Incorrect settings can cause the indoor unit malfunction.
- After the power is turned on, perform the “Function setting” according to the installation conditions using the remote controller.
- The settings may be selected between the following two: Function number or Setting number.
- Settings will not be changed if invalid numbers or setting numbers are selected.
- This function cannot be used on the secondary units.

■ Preparation

Before connecting the power supply of the indoor unit, reconfirm following items:

- Piping air tight test and vacuuming have been performed firmly.
- There is no wiring mistake. Then, connect the power supply of the indoor unit.

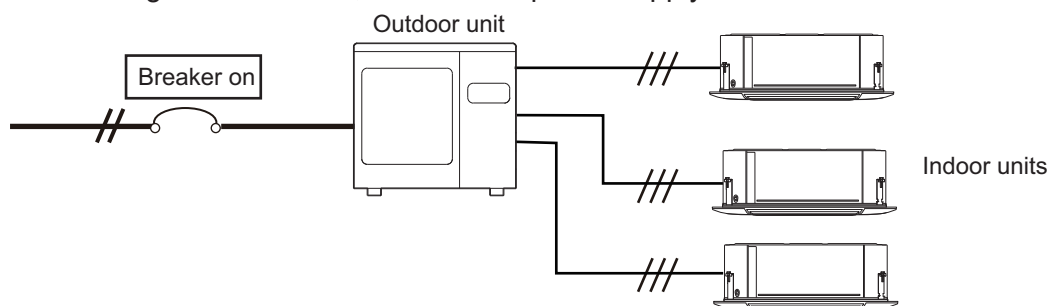

■ UTY-RNNYM

● Button name and function

During address setting mode, indoor unit reject the any operation command from remote controller.

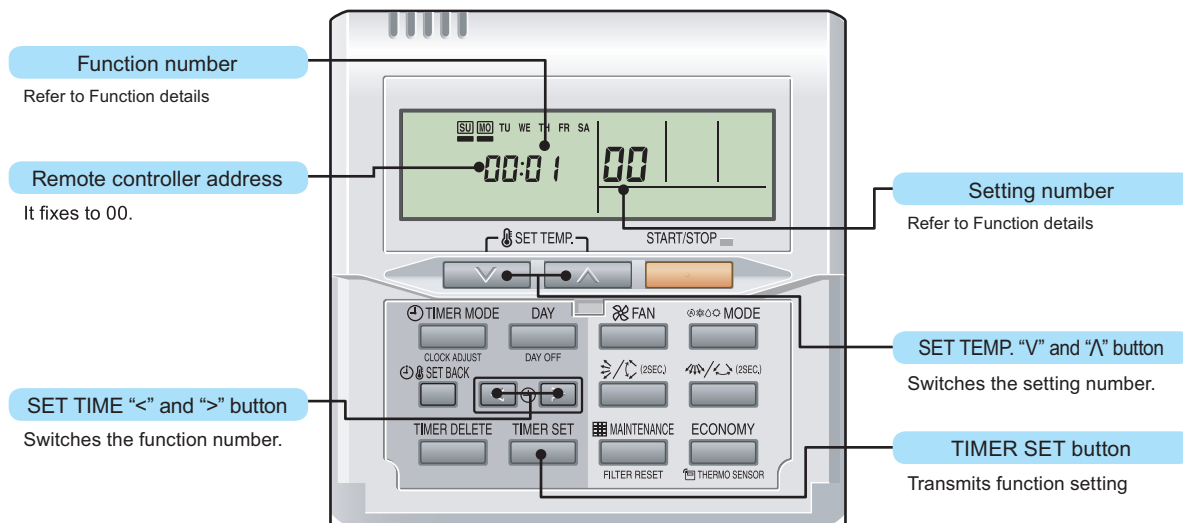

● Function setting procedure

1. Connect the power supply of the outdoor unit.
2. Switch to the function setting mode.
To enter the function setting mode, hold down the 3 buttons of SET TEMP. ∇, SET TEMP. ▲, and FAN at the same time for 5 seconds or longer.

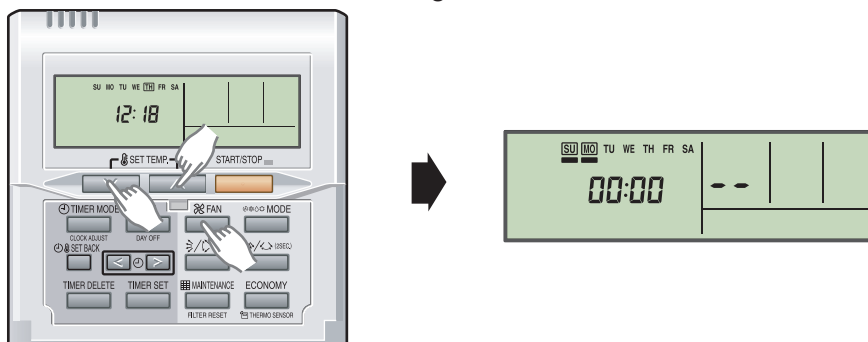

3. Select the function number by pressing the SET TIME < or the SET TIME > button.

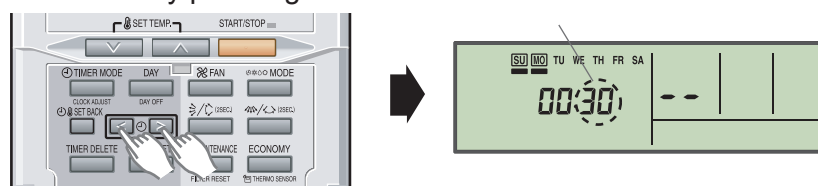

4. Select the setting number by pressing the SET TEMP. ▲ or the SET TEMP. ∇ button. The display flashes during setting number selection.

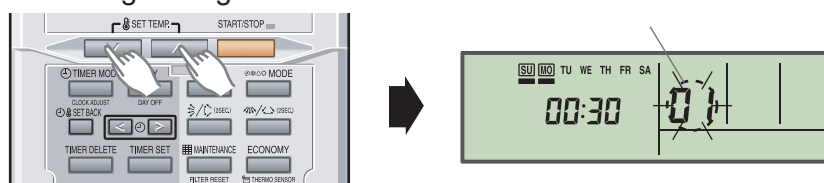

5. Confirm the setting by pressing the TIMER SET button.
The data will be transferred to the indoor unit.

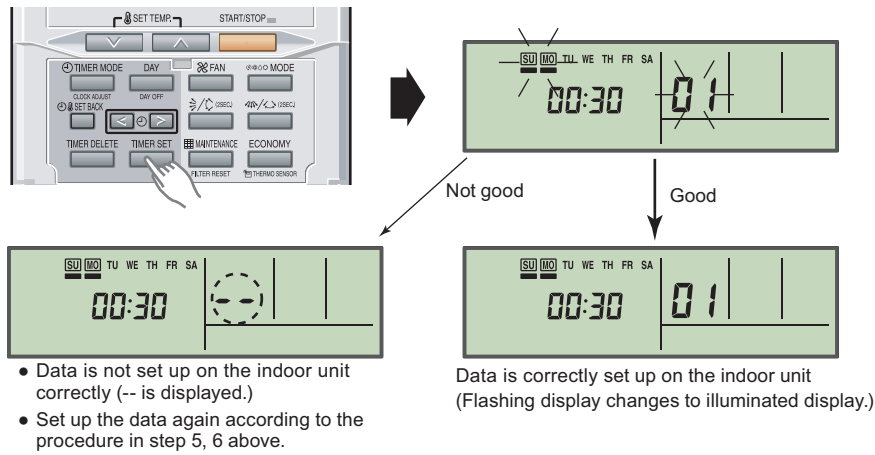

Function details: Refer to [Chapter 1-8. "Function details"](#) on page 05-27.

6. Exit the function setting mode by holding 3 buttons of SET TEMP. ∇ , SET TEMP. \wedge and FAN at the same time.

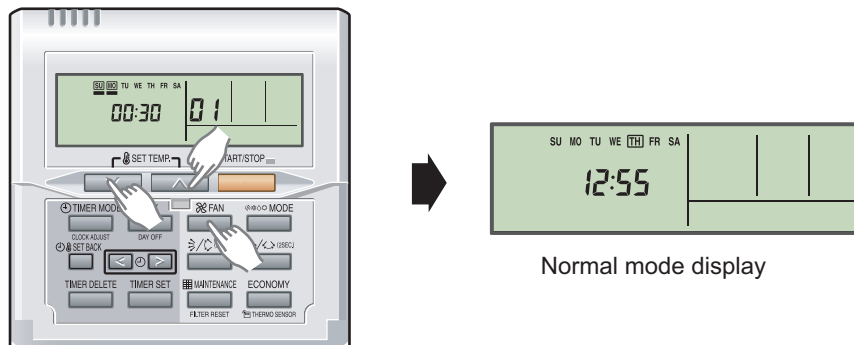

If no button is pressed within 60 seconds after buttons mentioned above are pressed, it will automatically exit the function setting mode.

If you exit the function setting mode unintentionally during setting, enter the mode again according to the procedure in step 2.

● Setting up each indoor unit

Repeat the procedures from step 1 to 6, and set up the indoor units requiring function setting.

● Resetting the power after setting up function of all indoor units

NOTES:

- If the reset is not performed, function cannot be read correctly.
- After all the functions have been set, the circuit breaker needs to be switched off for at least 2 minutes.
 - After the 2 minutes has passed, power can be restored.
 - The set function is stored in the PCB and will remain in memory even when the power of indoor unit is turned off.
However setting function is effective after disconnecting the power supply and then reconnecting it.
- Record the latest configuration of the indoor unit function setting on a label, and put the label on the unit so it can be used for after-sales service operations.

■ UTY-RVNYM

● Function setting procedure

1. Connect the power supply of the outdoor unit.
2. Switch to the function setting mode.

When [Menu button] is pressed twice while “Monitor” screen is displayed, it switches to the “Submenu” screen. If [Menu button] is pressed while the “Submenu” screen is displayed, the display returns to the “Monitor” screen.

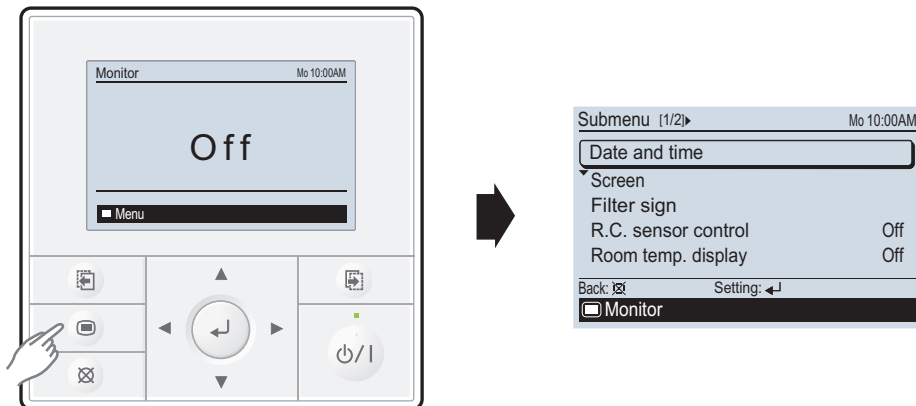

Press the [Screen switch button (Left)] and [Screen switch button (Right)] simultaneously for 5 seconds to switch to “Service” screen.

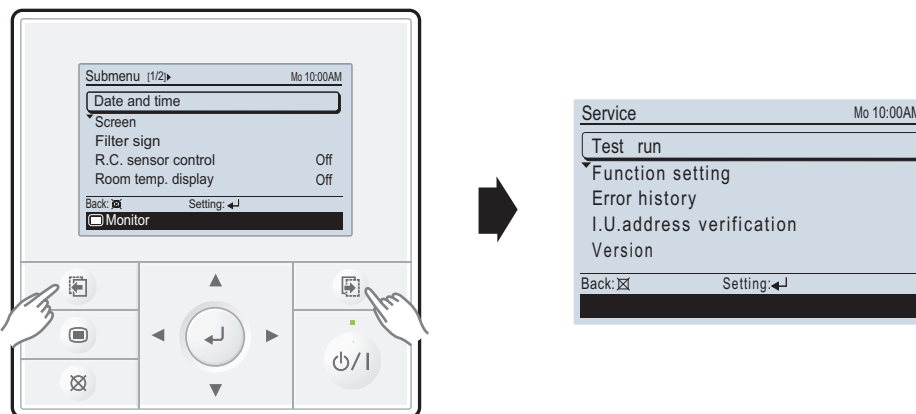

Select [Function setting] with pressing the [Cursor button (Up/Down)], and press the [Enter button].

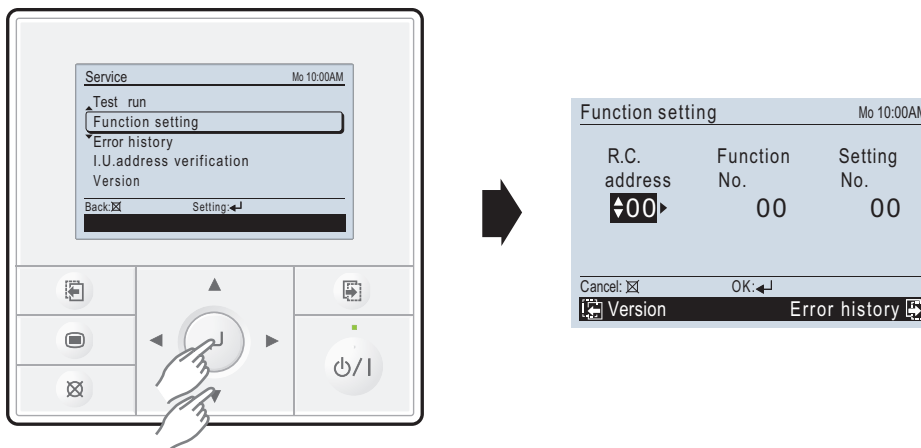

3. Select the [Function No.] with pressing the [Cursor button (Left/Right)], and select the Function No. to be set with pressing the [Cursor button (Up/Down)].

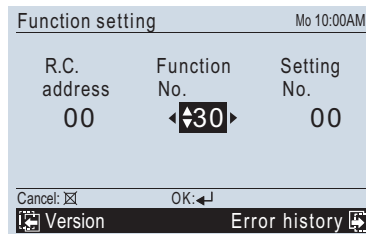
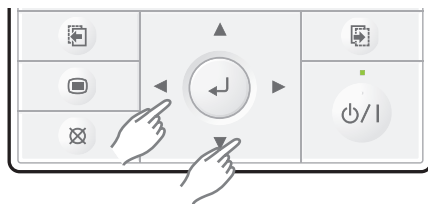

4. Select the [Setting No.] with pressing the [Cursor button (Left/Right)], and select the Setting No. to be set with pressing the [Cursor button (Up/Down)].

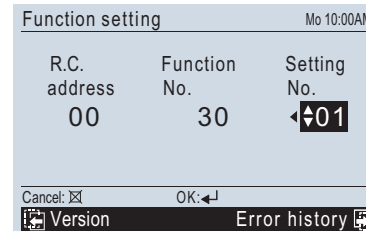
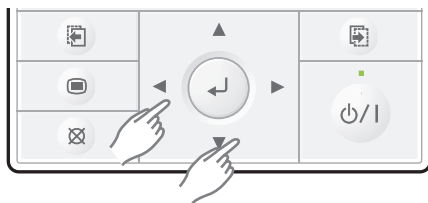

5. Pressing the [Enter button], confirm the setting. The data will be transferred to the indoor unit.

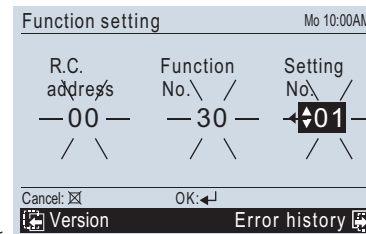
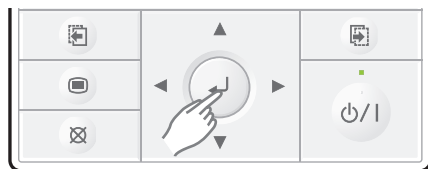

Error

Good

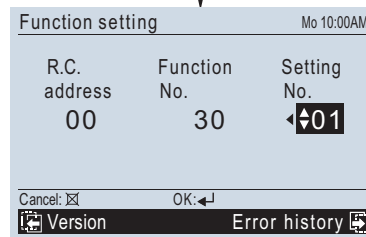
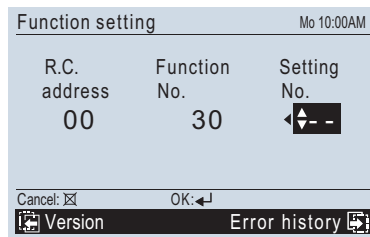

Function details: Refer to [Chapter 1-8. "Function details"](#) on page 05-27.

FIELD WORKING

FIELD WORKING

6. When [Cancel button] is pressed twice while “Function setting” screen is displayed, it switches to the “Submenu” screen.

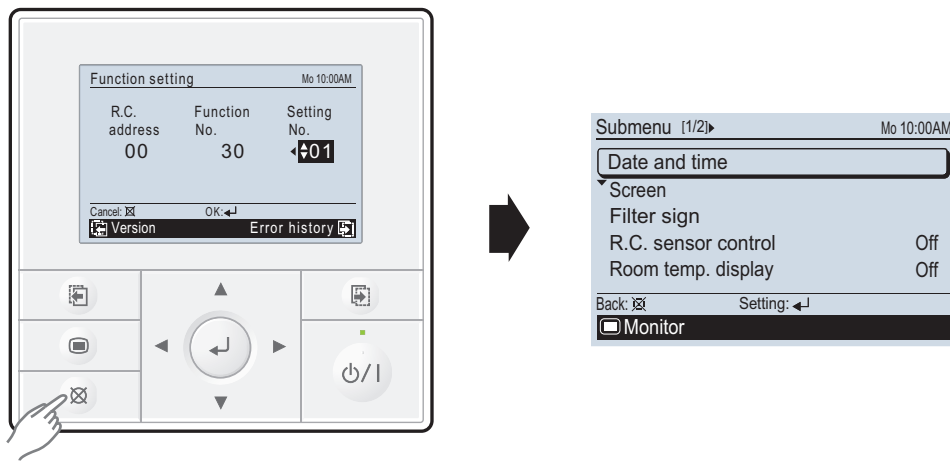

If no button is pressed within 60 seconds after buttons mentioned above are pressed, it will automatically exit the function setting mode.

If you exit the function setting mode unintentionally during setting, enter the mode again according to the procedure in step 2.

● Setting up each indoor unit

Repeat the procedures from step 1 to 6, and set up the indoor units requiring function setting.

● Resetting the power after setting up function of all indoor units

NOTES:

- If the reset is not performed, function cannot be read correctly.
- After all the functions have been set, the circuit breaker needs to be switched off for at least 2 minutes.
 - After the 2 minutes has passed, power can be restored.
 - The set function is stored in the PCB and will remain in memory even when the power of indoor unit is turned off. However setting function is effective after disconnecting the power supply and then reconnecting it.
- Record the latest configuration of the indoor unit function setting on a label, and put the label on the unit so it can be used for after-sales service operations.

1-7. Indoor unit (setting by simple remote controller)

- The function settings of the control of the indoor unit can be changed by this procedure according to the installation conditions. Incorrect settings can cause the indoor unit malfunction.
- After the power is turned on, perform the “Function setting” according to the installation conditions using the remote controller.
- The settings may be selected between the following two: Function number or Setting number.
- Settings will not be changed if invalid numbers or setting numbers are selected.
- This function cannot be used on the secondary units.

■ Preparation

Before connecting the power supply of the indoor unit, reconfirm following items:

- Piping air tight test and vacuuming have been performed firmly.
- There is no wiring mistake. Then, connect the power supply of the indoor unit.

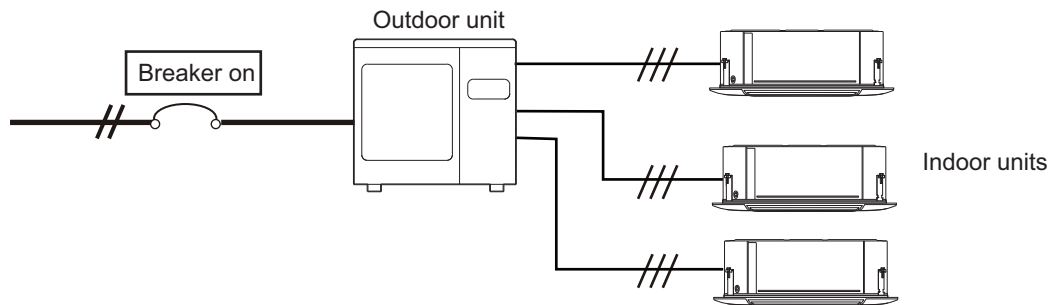

■ UTY-RSNYM

● Button name and function

During address setting mode, indoor unit reject the any operation command from remote controller.

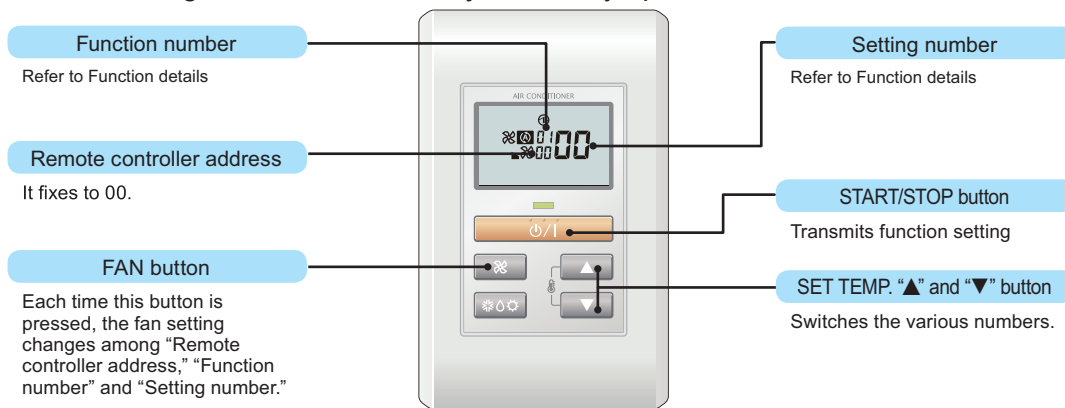

● Function setting procedure

1. Connect the power supply of the outdoor unit.
2. Switch to the function setting mode.

To enter the function setting mode, hold down the 3 buttons of SET TEMP. ▲, SET TEMP. ▼ and FAN at the same time for 5 seconds or longer.

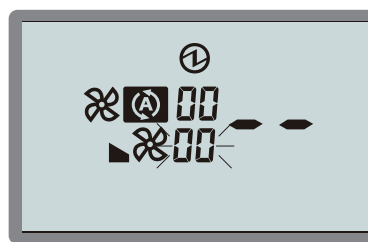
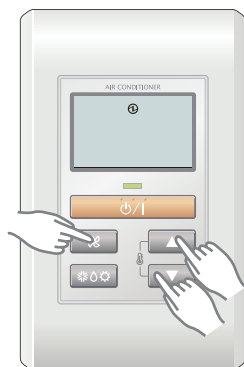

Function setting mode initial display

3. Press the FAN button.
The Function number indicator flashes. Then, press either the SET TEMP. ▲ button or the SET TEMP. ▼ button to set up the function number.

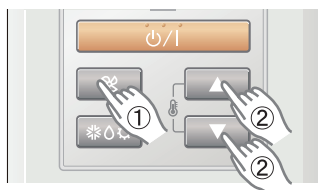

Function number

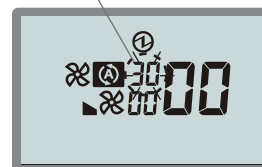

4. Select the setting number by pressing the SET TEMP. ▲ or SET TEMP. ▼ button. The setting number indicator flashes during setting number selection.

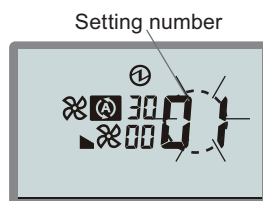
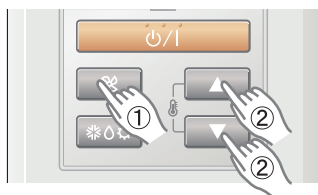

Example) Function number : 30, Setting number : 01

5. Confirm the setting by pressing the TIMER SET button. The data will be transferred to the indoor unit.



Good

Not good



- Data is not set up on the indoor unit correctly (-- is displayed.)
- Set up the data again according to the procedure in step 3, 4 above.

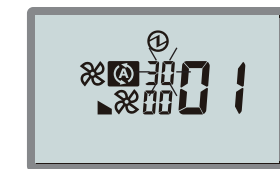

Data is correctly set up on the indoor unit.

Function details: Refer to [Chapter 1-8. "Function details"](#) on page 05-27.

6. Exit the function setting mode by pressing the 3 buttons of SET TEMP. ▲, SET TEMP. ▼, and FAN at the same time for 5 seconds or longer. After exiting the function setting mode, the display returns to the normal mode.

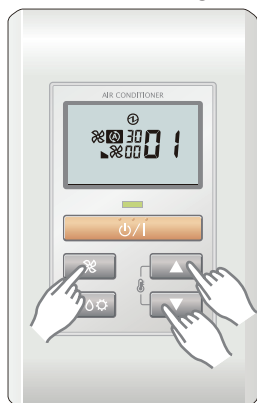

Normal mode display

If no button is pressed within 60 seconds after buttons mentioned above are pressed, it will automatically exit the function setting mode.

If you exit the function setting mode unintentionally during setting, enter the mode again according to the procedure in step 2.

● Setting up each indoor unit

Repeat the procedures from step 1 to 6, and set up the indoor units requiring function setting.

● Resetting the power after setting up function of all indoor units

NOTES:

- If the reset is not performed, function cannot be read correctly.
- After all the functions have been set, the circuit breaker needs to be switched off for at least 2 minutes.
 - After the 2 minutes has passed, power can be restored.
 - The set function is stored in the PCB and will remain in memory even when the power of indoor unit is turned off.
However setting function is effective after disconnecting the power supply and then reconnecting it.
- Record the latest configuration of the indoor unit function setting on a label, and put the label on the unit so it can be used for after-sales service operations.

1-8. Function details

■ Contents of function setting

Each function setting listed in this section is adjustable in accordance with the installation environment.

NOTE: Setting will not be changed if invalid numbers or setting values are selected.

● Function setting list

	Function no.	Functions	Compact cassette	Slim duct	Duct
1)	02	Refrigerant circuit address	●	●	●
2)	11	Filter sign	●	●	●
3)	20	Ceiling height	●	—	—
4)	21	Static pressure	—	—	●
5)	22	Outlet directions	●	—	—
6)	26	Static pressure	—	●	—
7)	30/31	Room temperature control for indoor unit sensor	●	●	●
8)	35/36	Room temperature control for wired remote controller sensor	●	●	●
9)	40	Auto restart	●	●	●
10)	42	Room temperature sensor switching	●	●	●
11)	44	Remote controller custom code	●	●	●
12)	46	External input control	●	●	●
13)	48	Room temperature sensor switching (Aux.)	●	●	●
14)	49	Indoor unit fan control for energy saving for cooling	●	●	●
15)	60	Switching functions for external output terminal	●	●	●

1) Refrigerant circuit address

Assign the same number to all of the indoor units connected to an outdoor unit.

Function number	Setting value	Refrigerant circuit address
02	00 to 15	00
		01
		~
		14
		15

2) Filter sign

Select appropriate intervals for displaying the filter sign on the indoor unit according to the estimated amount of dust in the air of the room.

If the indication is not required, select "No indication" (03).

Function number	Setting value	Setting description	Factory setting
11	00	Standard	
	01	Long interval	
	02	Short interval	
	03	No indication	◆

Setting description	Compact cassette	Slim duct	Duct
Standard	2,500 hours	400 hours	2,500 hours
Long interval	4,400 hours	1,000 hours	4,400 hours
Short interval	1,250 hours	200 hours	1,250 hours

3) Ceiling height (For Compact cassette type only)

Select the appropriate ceiling height according to the place of installation.

Function number	Setting value	Setting description	Factory setting
20	00	Standard	◆
	01	High ceiling	

For the specific height for each setting value, refer to "Installation space" in Chapter "Dimensions" on page 1.

In case of cassette type models:

The ceiling height values are for the 4-way outlet. Do not change this setting in the 3-way outlet mode.

4) Static pressure (For Duct type only)

Select the appropriate static pressure according to the installation conditions.

Function number	Setting value	Setting description	Factory setting
21	00	Normal	◆
	02	High static pressure 1	
	03	High static pressure 2	
	04	High static pressure 3	

5) Outlet directions (For Compact cassette type only)

Select the appropriate number of outlet directions according to the installation conditions.

Function number	Setting value	Setting description	Factory setting
22	00	4-way	◆
	01	3-way	

6) Static pressure (For Slim duct type only)

Select the appropriate static pressure according to the installation conditions.

Function number	Setting value	Setting description	Factory setting
26	00	0 Pa	
	01	10 Pa	
	02	20 Pa	
	03	30 Pa	
	04	40 Pa	
	05	50 Pa	
	06	60 Pa	
	07	70 Pa	
	08	80 Pa	
	09	90 Pa	
	31	Standard (25 Pa)	◆

7) Room temperature control for indoor unit sensor

Depending on the installed environment, correction of the room temperature sensor may be required. Select the appropriate control setting according to the installed environment.

The temperature of the room temperature sensor is corrected as follows:

Corrected temp. = Temp. of the room temp. sensor - Correction temp. value

Example of correction:

When the temperature of the room temp. sensor is 26°C and the setting value is "03" (-1.0°C), corrected temp. will be 27°C (26°C - [-1.0°C]).

The temperature correction values show the difference from the Standard setting "00" (manufacturer's recommended value).

Function number	Setting value	Setting description	Factory setting		
30 (For cooling)	31 (For heating)	00	Standard setting	◆	
		01	No correction 0.0 °C		
		02	-0.5 °C	More cooling Less heating	
		03	-1.0 °C		
		04	-1.5 °C		
		05	-2.0 °C		
		06	-2.5 °C		
		07	-3.0 °C		
		08	-3.5 °C		
		09	-4.0 °C		
		10	+0.5 °C	Less cooling More heating	
		11	+1.0 °C		
		12	+1.5 °C		
		13	+2.0 °C		
		14	+2.5 °C		
		15	+3.0 °C		
		16	+3.5 °C		
17	+4.0 °C				

8) Room temperature control for wired remote controller sensor

Depending on the installed environment, correction of the wire remote temperature sensor may be required. Select the appropriate control setting according to the installed environment.

To change this setting, set Function 42 to Both "01".

Ensure that the Thermo Sensor icon is displayed on the remote controller screen.

Function number		Setting value	Setting description	Factory setting	
35 (For cooling)	36 (For heating)	00	Standard setting	◆	
		01	No correction 0.0°C		
		02	-0.5 °C	More cooling Less heating	
		03	-1.0 °C		
		04	-1.5 °C		
		05	-2.0 °C		
		06	-2.5 °C		
		07	-3.0 °C		
		08	-3.5 °C		
		09	-4.0 °C		
		10	+0.5 °C	Less cooling More heating	
		11	+1.0 °C		
		12	+1.5 °C		
		13	+2.0 °C		
		14	+2.5 °C		
		15	+3.0 °C		
		16	+3.5 °C		
17	+4.0 °C				

9) Auto restart

Enables or disables automatic restart after a power interruption.

Function number	Setting value	Setting description	Factory setting
40	00	Enable	◆
	01	Disable	

NOTE: Auto restart is an emergency function such as for power outage etc. Do not attempt to use this function in normal operation. Be sure to operate the unit by remote controller or external device.

10) Room temperature sensor switching

(Only for wired remote controller)

When using the wired remote controller temperature sensor, change the setting to "Both" (01).

Function number	Setting value	Setting description	Factory setting
42	00	Indoor unit	◆
	01	Both	

00: Sensor on the indoor unit is active.

01: Sensors on both indoor unit and wired remote controller are active.

NOTE: Remote controller sensor must be turned on by using the remote controller.

11) Remote controller custom code

(Only for wireless remote controller)

The indoor unit custom code can be changed. Select the appropriate custom code.

Function number	Setting value	Setting description	Factory setting
44	00	A	◆
	01	B	
	02	C	
	03	D	

12) External input control

"Operation/Stop" mode or "Forced stop" mode can be selected.

Function number	Setting value	Setting description	Factory setting
46	00	Operation/Stop mode 1	◆
	01	(Setting prohibited)	
	02	Forced stop mode	
	03	Operation/Stop mode 2	

13) Room temperature sensor switching (Aux.)

To use the temperature sensor on the wired remote controller only, change the setting to "Wired remote controller" (01).

This function will only work if the function setting 42 is set at "Both" (01).

When the setting value is set to "Both" (00), more suitable control of the room temperature is possible by setting function setting 30 and 31 too.

Function number	Setting value	Setting description	Factory setting
48	00	Both	◆
	01	Wired remote controller	

14) Indoor unit fan control for energy saving for cooling

Enables or disables the power-saving function by controlling the indoor unit fan rotation when the outdoor unit is stopped during cooling operation.

Function number	Setting value	Setting description	Factory setting
49	00	Disable	
	01	Enable	
	02	Remote controller	◆

00: When the outdoor unit is stopped, the indoor unit fan operates continuously following the setting on the remote controller.

01: When the outdoor unit is stopped, the indoor unit fan operates intermittently at a very low speed.

02: Enable or disable this function by remote controller setting.

NOTES:

- As the factory setting, this setting is initially activated.
- Set to "00" or "01" when connecting a remote controller that cannot set the Fan control for energy saving function or connecting a network converter.
To confirm if the remote controller has this setting, refer to the operating manual of each remote controller.

15) Primary and secondary settings

Set the indoor unit that is connected to the outdoor unit using a transmission cable as the primary.

Function number	Setting value	Setting description	Factory setting
51	00	Primary	◆
	01	Secondary	

16) Switching functions for external output terminal

Functions of the external output terminal can be switched. For details, refer to “External input and output”.

Function number	Setting value	Setting description	Factory setting
60	00	Operation status	◆
	01—08	(Setting prohibited)	
	09	Error status	
	10	Fresh air control	
	10	Indoor unit fan operation status	
	11	External heater	

1-9. Wired remote controller (UTY-RNNYM)

DIP switch 1	SW1	Prohibited
	SW2	Dual remote controller setting
	SW3	Prohibited
	SW4	°F/°C switch
	SW5	Prohibited
	SW6	Memory backup setting

* Do not use DIP switch 2.

Switch location

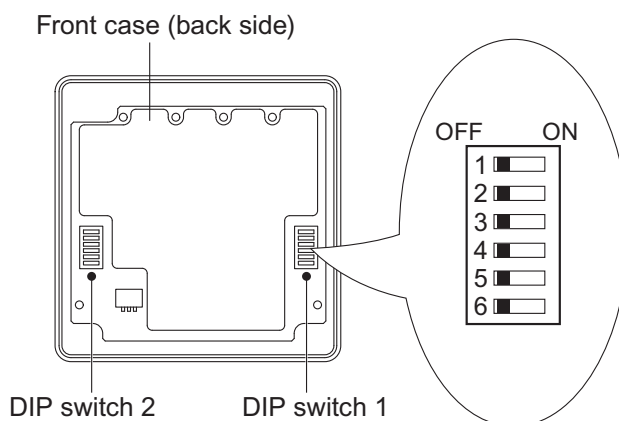

DIP switch 1 setting

SW2: Dual remote controller setting

Set the remote controller SW2 according to the following table.

Number of remote controller	Primary unit	Secondary unit	Factory setting
	SW2	SW2	
1 (Normal)	OFF	—	◆
2 (Dual)	OFF	ON	

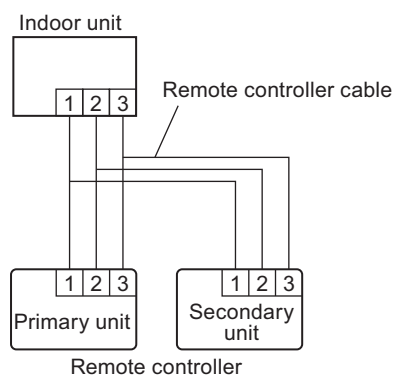

SW4: Switching temperature unit °F / °C

Displayed temperature unit can be switched between Fahrenheit (°F) and Celsius (°C).

SW4	Fahrenheit (°F) / Celsius (°C)	Factory setting
OFF	°C	◆
ON	°F	

● SW6: Memory backup setting

Set to "ON" to use batteries for the memory backup.

When batteries are not used, all of settings stored in memory will be deleted if there is a power failure.

SW6	Memory backup	Factory setting
OFF	Disable	◆
ON	Enable	

1-10. Wired remote controller (UTY-RVNYM)

DIP switch 1	SW1	Memory backup setting
	SW2	Dual remote controller setting

■ Switch location

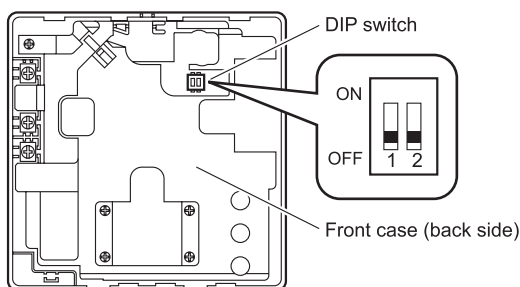

■ DIP switch setting

● SW1: Memory backup setting

Set to "ON" to use batteries for the memory backup.

When batteries are not used, all of settings stored in memory will be deleted if there is a power failure.

SW1	Memory backup	Factory setting
OFF	Disable	◆
ON	Enable	

● SW2: Dual remote controller setting

Set the remote controller SW2 according to the following table.

Number of remote controller	Primary unit	Secondary unit	Factory setting
	SW2	SW2	
1 (Normal)	OFF	—	◆
2 (Dual)	OFF	ON	

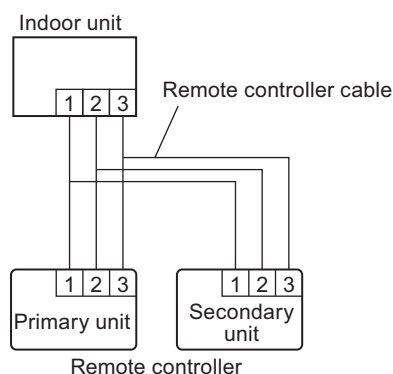

1-11. Simple remote controller (UTY-RSNYM)

DIP switch	SW1	Prohibited
	SW2	Dual remote controller setting
	SW3	°F/°C switch
	SW4	Prohibited
	SW5	Prohibited
	SW6	Prohibited

Switch location

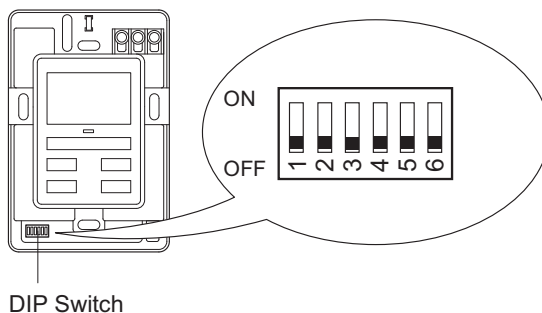

DIP switch setting

SW2: Dual remote controller setting

Set the remote controller SW2 according to the following table.

Number of remote controller	Primary unit	Secondary unit	Factory setting
	SW2	SW2	
1 (Normal)	OFF	—	◆
2 (Dual)	OFF	ON	

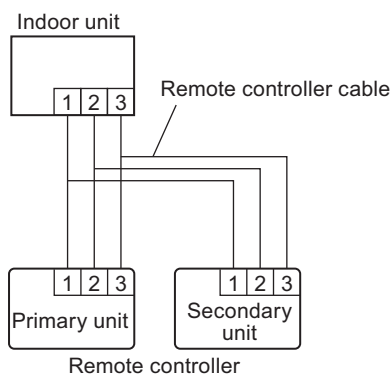

SW3: Switching temperature unit °F / °C

Displayed temperature unit can be switched between Fahrenheit (°F) and Celsius (°C).

SW3	Fahrenheit (°F) / Celsius (°C)	Factory setting
OFF	°C	◆
ON	°F	