

Contents

1. SAFETY PRECAUTIONS.....	1
2. PRODUCT SPECIFICATION.....	3
2.1. Installation tools.....	3
2.2. Accessories.....	4
2.3. Pipe requirements.....	4
2.4. Electrical requirements.....	4
2.5. General information.....	5
3. INSTALLATION WORK.....	5
3.1. Installation dimensions.....	5
3.2. Transporting the unit.....	6
3.3. Mounting the unit.....	6
3.4. Drain installation.....	7
3.5. Pipe installation.....	7
3.6. Sealing test.....	8
3.7. Vacuum process.....	9
3.8. Electrical wiring.....	9
4. TEST RUN.....	12
4.1. Pre-test run check items.....	12
4.2. Test operation method.....	12
4.3. Checklist.....	12
5. FINISHING.....	13
5.1. Installing insulation.....	13
5.2. Filling with putty.....	13
6. HOW TO OPERATE DISPLAY UNIT.....	13
6.1. Display unit position.....	13
6.2. Description of display and buttons.....	13
7. FIELD SETTING.....	14
7.1. Field setting buttons.....	14
7.2. Function settings.....	14
8. EXTERNAL INPUT AND OUTPUT.....	15
8.1. External input.....	15
8.2. External output.....	16
9. PUMP DOWN.....	16
9.1. Preparation for pump down.....	17
9.2. Pump down procedure.....	17
10. ERROR CODES.....	17
10.1. Error display mode.....	17
10.2. Error code check table.....	18

1. SAFETY PRECAUTIONS

- Be sure to read this manual thoroughly before installation.
- The warnings and precautions indicated in this manual contain important information pertaining to your safety. Be sure to observe them.
- Hand this manual, together with the operating manual, to the customer. Request the customer to keep them on hand for future use, such as for relocating or repairing the unit.

⚠ WARNING

Indicates a potentially or imminently hazardous situation which, if not avoided, could result in death or serious injury.

⚠ CAUTION

Indicates a potentially hazardous situation that may result in minor or moderate injury or damage to property.

⚠ WARNING

- Installation of this product must be done by experienced service technicians or professional installers only in accordance with this manual. Installation by nonprofessional or improper installation of the product may cause serious accidents such as injury, water leakage, electric shock, or fire. If the product is installed in disregard of the instructions in this manual, it will void the manufacturer's warranty.
- To avoid getting an electric shock, never touch the electrical components soon after the power supply has been turned off. After turning off the power, always wait 10 minutes or more before you touch the electrical components.
- Do not turn on the power until all work has been completed. Turning on the power before the work is completed can cause serious accidents such as electric shock or fire.
- If refrigerant leaks while work is being carried out, ventilate the area. If the refrigerant comes in contact with a flame, it produces a toxic gas.
- Installation must be performed in accordance with regulations, codes, or standards for electrical wiring and equipment in each country, region, or the installation place.
- Do not use this equipment with air or any other unspecified refrigerant in the refrigerant lines. Excess pressure can cause a rupture.
- During installation, make sure that the refrigerant pipe is attached firmly before you run the compressor.
Do not operate the compressor under the condition of refrigerant piping not attached properly with 3-way valve open. This may cause abnormal pressure in the refrigeration cycle that leads to rupture and even injury.
- When installing or relocating the air conditioner, do not mix gases other than the specified refrigerant (R32) to enter the refrigerant cycle.
If air or other gas enters the refrigerant cycle, the pressure inside the cycle will rise to an abnormally high value and cause rupture, injury, etc.
- To connect the indoor unit and outdoor unit, use air conditioner piping and cables available locally as standard parts. This manual describes proper connections using such installation set.
- Do not modify power cable, use extension cable or branch wiring. Improper use may cause electric shock or fire by poor connection, insufficient insulation or over current.
- Do not purge the air with refrigerants but use a vacuum pump to vacuum the installation.
- There is not extra refrigerant in the outdoor unit for air purging.
- Use a vacuum pump for R32 or R410A exclusively.
- Using the same vacuum pump for different refrigerants may damage the vacuum pump or the unit.
- Use a clean gauge manifold and charging hose for R32 or R410A exclusively.
- Do not use means to accelerate the defrosting process or to clean, other than those recommended by the manufacturer.
- The appliance shall be stored in a room without continuously operating ignition sources (for example: open flames, an operating gas appliance or an operating electric heater).
- Do not pierce or burn.
- Be aware that refrigerants may not contain an odour.
- During the pump-down operation, make sure that the compressor is turned off before you remove the refrigerant piping.
Do not remove the connection pipe while the compressor is in operation with 3-way valve open.
This may cause abnormal pressure in the refrigeration cycle that leads to rupture and even injury.
- This appliance is not intended for use by persons (including children) with reduced physical, sensory or mental capabilities, or lack of experience and knowledge, unless they have been given supervision or instruction concerning use of the appliance by a person responsible for their safety. Children should be supervised to ensure that they do not play with the appliance.

⚠ CAUTION

- For the air conditioner to work appropriately, install it as written in this manual.
- This product must be installed by qualified personnel with a capacity certification of handling refrigerant fluids. Refer to regulation and laws in use on installation place.
- Install the product by following local codes and regulations in force at the place of installation, and the instructions provided by the manufacturer.
- This product is part of a set constituting an air conditioner. The product must not be installed alone or be installed with non-authorized device by the manufacturer.
- Always use a separate power supply line protected by a circuit breaker operating on all wires with a distance between contact of 3 mm for this product.
- To protect the persons, earth (ground) the product correctly, and use the power cable combined with an Earth Leakage Circuit Breaker (ELCB).
- This product is not explosion proof, and therefore should not be installed in explosive atmosphere.
- This product contains no user-serviceable parts. Always consult experienced service technicians for repairing.
- When installing pipes shorter than 3 m, sound of the outdoor unit will be transferred to the indoor unit, which will cause large operating sound or some abnormal sound.
- When moving or relocating the air conditioner, consult experienced service technicians for disconnection and reinstallation of the product.
- Do not touch the fins of the heat exchanger. Touching the heat exchanger fins could result in damage to the fins or personal injury such as skin rupture.
- An indoor unit error (error code: 2-3) occurs if an indoor unit for R410A is connected to the refrigerant system in a concurrent multiple connection environment. In that case, note the indoor model name that experiences the error, and contact our service centre.

Precautions for using R32 refrigerant

The basic installation work procedures are the same as conventional refrigerant (R410A, R22) models.

However, pay careful attention to the following points:

WARNING

- Since the working pressure is 1.6 times higher than that of refrigerant R22 models, some of the piping and installation and service tools are special. (Refer to "2.1. Installation tools".)
Especially, when replacing a refrigerant R22 model with a new refrigerant R32 model, always replace the conventional piping and flare nuts with the R32 and R410A piping and flare nuts on the outdoor unit side.
For R32 and R410A, the same flare nut on the outdoor unit side and pipe can be used.
- Models that use refrigerant R32 and R410A have a different charging port thread diameter to prevent erroneous charging with refrigerant R22 and for safety. Therefore, check beforehand. [The charging port thread diameter for R32 and R410A is 1/2 inch.]
- Be more careful than R22 so that foreign matter (oil, water, etc.) does not enter the piping.
Also, when storing the piping, securely seal the opening by pinching, taping, etc. (Handling of R32 is similar to R410A.)

CAUTION

1. Installation (Space)

- That the installation of pipe-work shall be kept to a minimum.
- That pipe-work shall be protected from physical damage.
- That compliance with national gas regulations shall be observed.
- That mechanical connections shall be accessible for maintenance purposes.
- In cases that require mechanical ventilation, ventilation openings shall be kept clear of obstruction.
- When disposing of the product is used, be based on national regulations, properly processed.

2. Servicing

2-1. Service personnel

- Any person who is involved with working on or breaking into a refrigerant circuit should hold a current valid certificate from an industry-accredited assessment authority, which authorizes their competence to handle refrigerants safely in accordance with an industry recognised assessment specification.
- Servicing shall only be performed as recommended by the equipment manufacturer. Maintenance and repair requiring the assistance of other skilled personnel shall be carried out under the supervision of the person competent in the use of flammable refrigerants.
- Servicing shall be performed only as recommended by the manufacturer.

2-2. Work

- Prior to beginning work on systems containing flammable refrigerants, safety checks are necessary to ensure that the risk of ignition is minimised. For repair to the refrigerating system, the precautions in 2-2 to 2-8 shall be complied with prior to conducting work on the system.
- Work shall be undertaken under a controlled procedure so as to minimize the risk of a flammable gas or vapour being present while the work is being performed.
- All maintenance staff and others working in the local area shall be instructed on the nature of work being carried out.
- Work in confined spaces shall be avoided.
- The area around the workspace shall be sectioned off.
- Ensure that the conditions within the area have been made safe by control of flammable material.

2-3. Checking for presence of refrigerant

- The area shall be checked with an appropriate refrigerant detector prior to and during work, to ensure the technician is aware of potentially flammable atmospheres.
- Ensure that the leak detection equipment being used is suitable for use with flammable refrigerants, i.e. non sparking, adequately sealed or intrinsically safe.

2-4. Presence of fire extinguisher

- If any hot work is to be conducted on the refrigeration equipment or any associated parts, appropriate fire extinguishing equipment shall be available at hand.
- Have a dry powder or CO₂ fire extinguisher adjacent to the charging area.

2-5. No ignition sources

- No person carrying out work in relation to a refrigeration system which involves exposing any pipe work that contains or has contained flammable refrigerant shall use any sources of ignition in such a manner that it may lead to the risk of fire or explosion.
- All possible ignition sources, including cigarette smoking, should be kept sufficiently far away from the site of installation, repairing, removing and disposal, during which flammable refrigerant can possibly be released to the surrounding space.
- Prior to work taking place, the area around the equipment is to be surveyed to make sure that there are no flammable hazards or ignition risks. "No Smoking" signs shall be displayed.

2-6. Ventilated area

- Ensure that the area is in the open or that it is adequately ventilated before breaking into the system or conducting any hot work.
- A degree of ventilation shall continue during the period that the work is carried out.
- The ventilation should safely disperse any released refrigerant and preferably expel it externally into the atmosphere.

2-7. Checks to the refrigeration equipment

- Where electrical components are being changed, they shall be fit for the purpose and to the correct specification.
- At all times the manufacturer's maintenance and service guidelines shall be followed.
- If in doubt consult the manufacturer's technical department for assistance.
- The following checks shall be applied to installations using flammable refrigerants.
 - The charge size is in accordance with the room size within which the refrigerant containing parts are installed.
 - The ventilation machinery and outlets are operating adequately and are not obstructed.
 - If an indirect refrigerating circuit is being used, the secondary circuit shall be checked for the presence of refrigerant.
 - Marking to the equipment continues to be visible and legible. Markings and signs that are illegible shall be corrected.
 - Refrigeration pipe or components are installed in a position where they are unlikely to be exposed to any substance which may corrode refrigerant containing components, unless the components are constructed of materials which are inherently resistant to being corroded or are suitably protected against being so corroded.

2-8. Checks to electrical devices

- Repair and maintenance to electrical components shall include initial safety checks and component inspection procedures.
- If a fault exists that could compromise safety, then no electrical supply shall be connected to the circuit until it is satisfactorily dealt with.
- If the fault cannot be corrected immediately but it is necessary to continue operation, an adequate temporary solution shall be used.
- This shall be reported to the owner of the equipment so all parties are advised.
- Initial safety checks shall include.
 - That capacitors are discharged: this shall be done in a safe manner to avoid possibility of sparking.
 - That there no live electrical components and wiring are exposed while charging, recovering or purging the system.
 - That there is continuity of earth bonding.

3. Repairs to sealed components

- During repairs to sealed components, all electrical supplies shall be disconnected from the equipment being worked upon prior to any removal of sealed covers, etc.
 - If it is absolutely necessary to have an electrical supply to equipment during servicing, then a permanently operating form of leak detection shall be located at the most critical point to warn of a potentially hazardous situation.
 - Particular attention shall be paid to the following to ensure that by working on electrical components, the casing is not altered in such a way that the level of protection is affected.
 - This shall include damage to cables, excessive number of connections, terminals not made to original specification, damage to seals, incorrect fitting of glands, etc.
 - Ensure that apparatus is mounted securely.
 - Ensure that seals or sealing materials have not degraded such that they no longer serve the purpose of preventing the ingress of flammable atmospheres.
 - Replacement parts shall be in accordance with the manufacturer's specifications.
- NOTES: The use of silicon sealant may inhibit the effectiveness of some types of leak detection equipment.
Intrinsically safe components do not have to be isolated prior to working on them.

4. Repair to intrinsically safe components

- Do not apply any permanent inductive or capacitance loads to the circuit without ensuring that this will not exceed the permissible voltage and current permitted for the equipment in use.
- Intrinsically safe components are the only types that can be worked on while live in the presence of a flammable atmosphere.
- The test apparatus shall be at the correct rating.
- Replace components only with parts specified by the manufacturer.
- Other parts may result in the ignition of refrigerant in the atmosphere from a leak.

5. Cabling

- Check that cabling will not be subject to wear, corrosion, excessive pressure, vibration, sharp edges or any other adverse environmental effects.
- The check shall also take into account the effects of aging or continual vibration from sources such as compressors or fans.

6. Detection of flammable refrigerants

- Under no circumstances shall potential sources of ignition be used in the searching for or detection of refrigerant leaks.
- A halide torch (or any other detector using a naked flame) shall not be used.

7. Leak detection methods

- Electronic leak detectors shall be used to detect flammable refrigerants, but the sensitivity may not be adequate, or may need re-calibration. (Detection equipment shall be calibrated in a refrigerant-free area.)
- Ensure that the detector is not a potential source of ignition and is suitable for the refrigerant used.
- Leak detection equipment shall be set at a percentage of the LFL of the refrigerant and shall be calibrated to the refrigerant employed and the appropriate percentage of gas (25 % maximum) is confirmed.
- Leak detection fluids are suitable for use with most refrigerants but the use of detergents containing chlorine shall be avoided as the chlorine may react with the refrigerant and corrode the copper pipe-work.
- If a leak is suspected, all naked flames shall be removed/extinguished.
- If a leakage of refrigerant is found which requires brazing, all of the refrigerant shall be recovered from the system, or isolated (by means of shut off valves) in a part of the system remote from the leak.
Oxygen free nitrogen (OFN) shall then be purged through the system both before and during the brazing process.

⚠ CAUTION

8. Removal and evacuation

- When breaking into the refrigerant circuit to make repairs – or for any other purpose –conventional procedures shall be used. However, it is important that best practice is followed since flammability is a consideration. The following procedure shall be adhered to:
 - remove refrigerant
 - purge the circuit with inert gas
 - evacuate
 - purge again with inert gas
 - open the circuit by cutting or brazing
- The refrigerant charge shall be recovered into the correct recovery cylinders.
- The system shall be “flushed” with OFN to render the unit safe.
- This process may need to be repeated several times.
- Compressed air or oxygen shall not be used for this task.
- Flushing shall be achieved by breaking the vacuum in the system with OFN and continuing to fill until the working pressure is achieved, then venting to atmosphere, and finally pulling down to a vacuum.
- This process shall be repeated until no refrigerant is within the system.
- When the final OFN charge is used, the system shall be vented down to atmospheric pressure to enable work to take place.
- This operation is absolutely vital if brazing operations on the pipe work are to take place.
- Ensure that the outlet for the vacuum pump is not close to any ignition sources and there is ventilation available.

9. Charging procedures

- In addition to conventional charging procedures, the following requirements shall be followed.
 - Ensure that contamination of different refrigerants does not occur when using charging equipment.
 - Hoses or lines shall be as short as possible to minimize the amount of refrigerant contained in them.
 - Cylinders shall be kept upright.
 - Ensure that the refrigeration system is earthed prior to charging the system with refrigerant.
 - Label the system when charging is complete (if not already).
 - Extreme care shall be taken not to overfill the refrigeration system.
- Prior to recharging the system it shall be pressure tested with OFN.
- The system shall be leak tested on completion of charging but prior to commissioning.
- A follow up leak test shall be carried out prior to leaving the site.

10. Decommissioning

- Before carrying out this procedure, it is essential that the technician is completely familiar with the equipment and all its details.
- It is recommended good practice that all refrigerants are recovered safely.
- Prior to the task being carried out, an oil and refrigerant sample shall be taken in case analysis is required prior to re-use of reclaimed refrigerant.
- It is essential that electrical power is available before the task is commenced.
 - Become familiar with the equipment and its operation.
 - Isolate system electrically.
- Before attempting the procedure ensure that:
 - mechanical handling equipment is available, if required, for handling refrigerant cylinders;
 - all personal protective equipment is available and being used correctly;
 - the recovery process is supervised at all times by a competent person;
 - recovery equipment and cylinders conform to the appropriate standards.
- Pump down refrigerant system, if possible.
- If a vacuum is not possible, make a manifold so that refrigerant can be removed from various parts of the system.
- Make sure that cylinder is situated on the scales before recovery takes place.
- Start the recovery machine and operate in accordance with manufacturer’s instructions.
- Do not overfill cylinders. (No more than 80 % volume liquid charge).
- Do not exceed the maximum working pressure of the cylinder, even temporarily.
- When the cylinders have been filled correctly and the process completed, make sure that the cylinders and the equipment are removed from site promptly and all isolation valves on the equipment are closed off.
- Recovered refrigerant shall not be charged into another refrigeration system unless it has been cleaned and checked.





11. Labelling

- Equipment shall be labelled stating that it has been de-commissioned and emptied of refrigerant.
- The label shall be dated and signed.
- Ensure that there are labels on the equipment stating the equipment contains flammable refrigerant.

12. Recovery

- When removing refrigerant from a system, either for servicing or decommissioning, it is recommended good practice that all refrigerants are removed safely.
- When transferring refrigerant into cylinders, ensure that only appropriate refrigerant recovery cylinders are employed.
- Ensure that the correct number of cylinders for holding the total system charge are available.
- All cylinders to be used are designated for the recovered refrigerant and labelled for that refrigerant (i.e. special cylinders for the recovery of refrigerant).
- Cylinders shall be complete with pressure relief valve and associated shut-off valves in good working order.
- Empty recovery cylinders are evacuated and, if possible, cooled before recovery occurs.
- The recovery equipment shall be in good working order with a set of instructions concerning the equipment that is at hand and shall be suitable for the recovery of flammable refrigerants.
- In addition, a set of calibrated weighing scales shall be available and in good working order.
- Hoses shall be complete with leak-free disconnect couplings and in good condition.
- Before using the recovery machine, check that it is in satisfactory working order, has been properly maintained and that any associated electrical components are sealed to prevent ignition in the event of a refrigerant release. Consult manufacturer if in doubt.
- The recovered refrigerant shall be returned to the refrigerant supplier in the correct recovery cylinder, and the relevant Waste Transfer Note arranged.
- Do not mix refrigerants in recovery units and especially not in cylinders.
- If compressors or compressor oils are to be removed, ensure that they have been evacuated to an acceptable level to make certain that flammable refrigerant does not remain within the lubricant.
- The evacuation process shall be carried out prior to returning the compressor to the suppliers.
- Only electric heating to the compressor body shall be employed to accelerate this process.
- When oil is drained from a system, it shall be carried out safely.

Explanation of symbols displayed on the indoor unit or outdoor unit.

	WARNING	This symbol shows that this equipment uses a flammable refrigerant. If the refrigerant is leaked, together with an external ignition source, there is a possibility of ignition.
	CAUTION	This symbol shows that the Operation Manual should be read carefully.
	CAUTION	This symbol shows that a service personnel should be handling this equipment with reference to the Installation Manual.
	CAUTION	This symbol shows that there is information included in the Operation Manual and/or Installation Manual.

2. PRODUCT SPECIFICATION

2.1. Installation tools

⚠ WARNING

- To install a unit that uses R32 refrigerant, use dedicated tools and piping materials that have been manufactured specifically for R32(R410A) use. Because the pressure of R32 refrigerant is approximately 1.6 times higher than R22, failure to use dedicated piping material or improper installation can cause rupture or injury. Furthermore, it can cause serious accidents such as water leakage, electric shock, or fire.
- Do not use a vacuum pump or refrigerant recovery tools with a series motor, since it may ignite.

Tool name	Contents of change
Gauge manifold	Pressure is high and cannot be measured with a conventional (R22) gauge. To prevent erroneous mixing of other refrigerants, the diameter of each port has been changed. It is recommended the gauge with seals -0.1 to 5.3 MPa (-1 to 53 bar) for high pressure. -0.1 to 3.8 MPa (-1 to 38 bar) for low pressure.
Charge hose	To increase pressure resistance, the hose material and base size were changed. (R32/R410A)
Vacuum pump	A conventional vacuum pump can be used by installing a vacuum pump adapter. (Use of a vacuum pump with a series motor is prohibited.)
Gas leakage detector	Special gas leakage detector for HFC refrigerant R32/R410A.

■ Copper pipes





It is necessary to use seamless copper pipes and it is desirable that the amount of residual oil is less than 40 mg/10 m. Do not use copper pipes having a collapsed, deformed or discolored portion (especially on the interior surface). Otherwise, the expansion valve or capillary tube may become blocked with contaminants. As an air conditioner using R32(R410A) incurs pressure higher than when using conventional refrigerant, it is necessary to choose adequate materials.

2.2. Accessories

⚠ WARNING

For installation purposes, be sure to use the parts supplied by the manufacturer or other prescribed parts. The use of non-prescribed parts can cause serious accidents such as the unit falling, water leakage, electric shock, or fire.

- The following installation parts are supplied. Use them as required.
- Keep the Installation Manual in a safe place and do not discard any other accessories until the installation work has been completed.

Name and shape	Q'ty	Description
Installation manual 	1	This manual
Drain pipe 	1	For outdoor unit drain piping work (May not be supplied, depending on the model.)
Drain cap 	3	
One-touch bush 	2	For power supply cable and connection cable installation

2.3. Pipe requirements

⚠ CAUTION

- Do not use existing pipes.
- Use pipes that have clean external and internal sides without any contamination which may cause trouble during use, such as sulfur, oxide, dust, cutting waste, oil, or water.
- It is necessary to use seamless copper pipes.
Material: Phosphor deoxidized seamless copper pipes.
It is desirable that the amount of residual oil is less than 40 mg/10 m.
- Do not use copper pipes that have a collapsed, deformed, or discolored portion (especially on the interior surface). Otherwise, the expansion valve or capillary tube may become blocked with contaminants.
- Improper pipe selection will degrade performance. As an air conditioner using R32(R410A) incurs pressure higher than when using conventional refrigerant, it is necessary to choose adequate materials.

- Thicknesses of copper pipes used with R32(R410A) are as shown in the table.
- Never use copper pipes thinner than those indicated in the table even if they are available on the market.

Thicknesses of Annealed Copper Pipes

Pipe outside diameter [mm (in.)]	Thickness [mm]
6.35 (1/4)	0.80
9.52 (3/8)	0.80
12.70 (1/2)	0.80
15.88 (5/8)	1.00
19.05 (3/4)	1.20

2.3.1. Refrigerant pipe size and allowable piping length

⚠ CAUTION

- Keep the piping length between the indoor unit and outdoor unit within the allowable tolerance.
- The maximum lengths of this product are shown in the table. If the units are further apart than this, correct operation cannot be guaranteed.

■ Single type installation

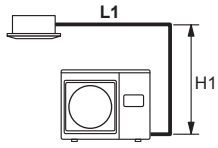
Capacity [Btu/h class]	30,000 ^{*1}	36,000	45,000	54,000
Pipe diameter <Liquid/Gas> (Standard) [mm (in.)]	9.52 (3/8) / 15.88 (5/8)			
Max. piping length (L1) [m]	30 ^{*2}			
Min. piping length (L1) [m]	5			
Max. height difference (H1) <Indoor unit to outdoor unit> [m]	30			
View (Example)				

*1: For the single phase type only.

*2: For the standard pipe diameter.

2.3.2 Connectable pipe diameter and max piping length

The figures enclosed by a thick-lined frame indicate the standard pipe diameter and max. piping length.

■ Single type installation

Capacity [Btu/h class]		30,000 ^{*1} / 36,000 / 45,000 / 54,000
Pipe diameter [mm (in.)]	Liquid pipes	9.52 (3/8)
	Gas pipes	15.88 (5/8)
Piping length [m (m)]	Max. piping length < L1 > ^{*2} (Pre-charge length)	30 [30]

*1: For the single phase type only.

*2: Refer to "View" in the table of "2.3.1. Refrigerant pipe size and allowable piping length" ■ Single type installation".

2.3.3. Protection of pipes

- Protect the pipes to prevent the entry of moisture and dust.
- Especially, pay attention when passing the pipes through a hole or connecting the end of a pipe to the outdoor unit.

Location	Working period	Protection method
Outdoor	1 month or more	Pinch pipes
	Less than 1 month	Pinch or tape pipes
Indoor	-	Pinch or tape pipes

2.4. Electrical requirements

⚠ CAUTION

- Be sure to install a breaker of the specified capacity.
- Before the electrical work, confirm electrical standards and regulations in each country, region, or installing place. Then select appropriate cables and breakers that comply with them.
- Equipment complying with IEC/ EN 61000-3-12
- This unit must be connected to a power supply with impedance of 0.419 ohm and below. If the power supply does not satisfy this requirement, please consult the power supplier.

Cable	Phase	Cable size [mm ²]	Type	Remarks
Power Supply Cable	Single	Min. 4	Type60245 IEC66	2 Cable + Earth (Ground) 1 Φ 230 V
	Three	Min. 2.5	Type60245 IEC57	4 Cable + Earth (Ground) 3 Φ 400 V
Connection Cable	Single	Min. 1.5	Type60245 IEC57	3 Cable + Earth (Ground) 1 Φ 230 V
	Three	Min. 1.5	Type60245 IEC57	3 Cable + Earth (Ground) 3 Φ 400 V

Cable Length: Limit voltage drop to less than 2%. Increase cable gauge if voltage drop is 2% or more.

Model	Phase	Breaker capacity [A]	Earth leakage breaker [mA]
30/36	Single	25	30
45/54	Single	32	
36/45/54	Three	16	

- Selected sample: Select the correct cable type and size according to the country or region's regulations.
- Select the breaker so that enough load current can pass through it.
- Before starting work check that power is not being supplied to all poles of the indoor unit and outdoor unit.
- Install all electrical works in accordance to standard.
- Install the disconnect device with a contact gap of at least 3 mm in all poles nearby the units. (Both indoor unit and outdoor unit)

2.5. General information

- If the unit is operated outside the operating temperature range, various protective circuit mechanisms may be activated and the unit may stop operating. For the operating temperature range, refer to the product FICHE or the specification manual.

3. INSTALLATION WORK

Make sure to obtain the customer's approval for selecting and installing the outdoor unit.

⚠ WARNING

- Securely install the outdoor unit at a location that can withstand the weight of the unit. Otherwise, the outdoor unit may fall and cause injury.
- Be sure to install the outdoor unit as prescribed, so that it can withstand earthquakes and typhoons or other strong winds. Improper installation can cause the unit to topple or fall, or other accidents.
- Do not install the outdoor unit near the edge of a balcony. Otherwise, children may climb onto the outdoor unit and fall off of the balcony.

⚠ CAUTION

- Do not install the outdoor unit in the following areas:
 - Area with high salt content, such as at the seaside. It will deteriorate metal parts, causing the parts to fail or the unit to leak water.
 - Area filled with mineral oil or containing a large amount of splashed oil or steam, such as a kitchen. It will deteriorate plastic parts, causing the parts to fail or the unit to leak water.
 - Area that generates substances that adversely affect the equipment, such as sulfuric gas, chlorine gas, acid, or alkali. It will cause the copper pipes and brazed joints to corrode, which can cause refrigerant leakage.
 - Area containing equipment that generates electromagnetic interference. It will cause the control system to malfunction, preventing the unit from operating normally.
 - Area that can cause combustible gas to leak, contains suspended carbon fibers or flammable dust, or volatile inflammables such as paint thinner or gasoline. If gas leaks and settles around the unit, it can cause a fire.
 - Area that has heat sources, vapors, or the risk of the leakage of flammable gas in the vicinity.
 - Area where small animals may live. It may cause failure, smoke or fire if small animals enter and touch internal electrical parts.
 - Area where animals may urinate on the unit or ammonia may be generated.
- Do not tilt the outdoor unit more than 3 degrees. However, do not install the unit with it tilted towards the side containing the compressor.
- Install the outdoor unit in a well-ventilated location away from rain or direct sunlight.
- If the outdoor unit must be installed in an area within easy reach of the general public, install as necessary a protective fence or the like to prevent their access.
- Install the outdoor unit in a location that would not inconvenience your neighbors, as they could be affected by the airflow coming out from the outlet, noise, or vibration. If it must be installed in proximity to your neighbors, be sure to obtain their approval.
- If the outdoor unit is installed in a cold region that is affected by snow accumulation, snow fall, or freezing, take appropriate measures to protect it from those elements. To ensure a stable operation, install inlet and outlet ducts.
- Install the outdoor unit in a location that is away from exhaust or the vent ports that discharge vapor, soot, dust, or debris.
- Install the indoor unit, outdoor unit, power supply cable, connection cable, and remote controller cable at least 1 m away from a television or radio receivers. The purpose of this is to prevent TV reception interference or radio noise. (Even if they are installed more than 1 m apart, you could still receive noise under some signal conditions.)
- If children under 10 years old may approach the unit, take preventive measures so that they cannot reach the unit.
- Keep the length of the piping of the indoor and outdoor units within the allowable range.
- For maintenance purposes, do not bury the piping.

Decide the mounting position with the customer as follows:

- (1) Install the outdoor unit in a location which can withstand the weight of the unit and vibration, and which can install horizontally.
- (2) Provide the indicated space to ensure good airflow.
- (3) If possible, do not install the unit where it will be exposed to direct sunlight. (If necessary, install a blind that does not interfere with the airflow.)
- (4) Do not install the unit near a source of heat, steam, or flammable gas.
- (5) During heating operation, drain water flows from the outdoor unit. Therefore, install the outdoor unit in a place where the drain water flow will not be obstructed.
- (6) Do not install the unit where strong wind blows or where it is very dusty.
- (7) Do not install the unit where people pass.
- (8) Install the outdoor unit in a place where it will be free from being dirty or getting wet by rain as much as possible.
- (9) Install the unit where connection to the indoor unit is easy.

3.1. Installation dimensions

⚠ CAUTION

Keep the space shown in the installation examples. If the installation is not performed accordingly, it could cause a short circuit and result in a lack of operating performance.

3.1.1. Single outdoor unit installation

When the upward area is open (Unit : mm)

(1) Obstacles at rear only

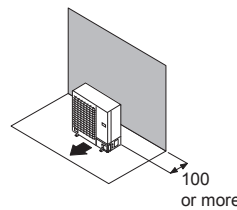

(2) Obstacles at rear and sides

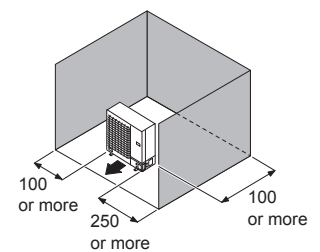

(3) Obstacles at front only

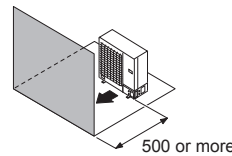

(4) Obstacles at front and rear

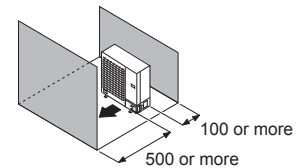

When an obstruction is present also in the upward area (Unit : mm)

(1) Obstacles at rear and above

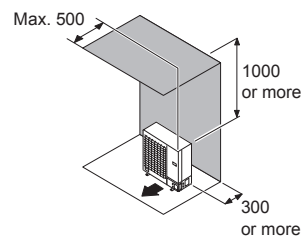

(2) Obstacles at rear, sides, and above

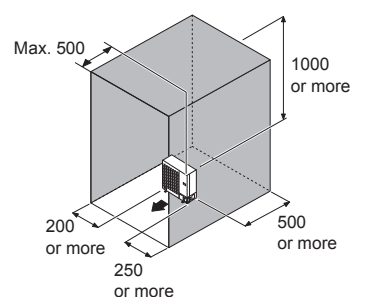

3.1.2. Multiple outdoor unit installation

- Provide at least 250 mm of space between the outdoor units if multiple units are installed.
- When routing the piping from the side of an outdoor unit, provide space for the piping.

When the upward area is open (Unit : mm)

(1) Obstacles at rear only

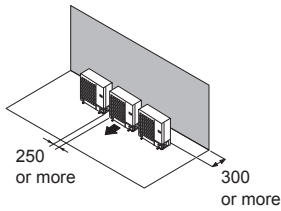

(2) Obstacles at front only

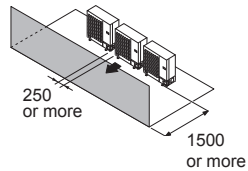

(3) Obstacles at front and rear

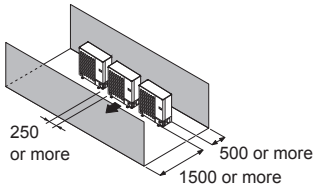

When an obstruction is present also in the upward area (Unit : mm)

(1) Obstacles at rear and above

- Up to 3 units can be installed side by side.
- When 4 units or more are arranged in a line, provide the space as shown below.

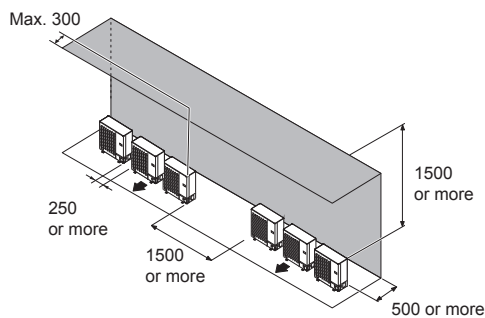

3.1.3. Outdoor units installation in multi row (Unit : mm)

(1) Single parallel unit arrangement

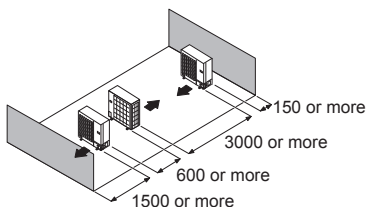

(2) Multiple parallel unit arrangement

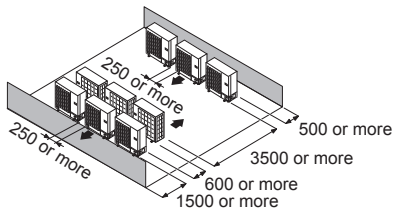

NOTES:

- If the space is larger than stated above, the condition will be the same as when there is no obstacle.
- When installing the outdoor unit, be sure to open the front and left side to obtain better operation efficiency.

3.2. Transporting the unit

⚠ WARNING

Do not touch the fins. Otherwise, personal injury could result.

⚠ CAUTION

When carrying the unit, hold the handles on the right and left sides and be careful. If the outdoor unit is carried from the bottom, hands or fingers may be pinched.

- Be sure to hold the handles on the sides of the unit. Otherwise, the suction grilles on the sides of the unit may be deformed.

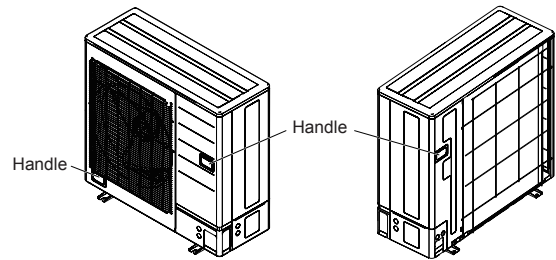

3.3. Mounting the unit

- Install 4 anchor bolts at the locations indicated with arrows in the figure.
- To reduce vibration, do not install the unit directly on the ground. Install it on a secure base (such as concrete blocks).
- The foundation shall support the legs of the unit and have a width of 50 mm or more.
- Depending on the installation conditions, the outdoor unit may spread its vibration during operation, which may cause noise and vibration. Therefore, attach damping materials (such as damping pads) to the outdoor unit during installation.
- Install the foundation, making sure that there is enough space for installing the connection pipes.
- Secure the unit to a solid block using foundation bolts. (Use 4 sets of commercially available M10 bolts, nuts, and washers.)
- The bolts should protrude 20 mm. (Refer to the figure.)
- If overturning prevention is required, purchase the necessary commercially available items.

(Unit : mm)

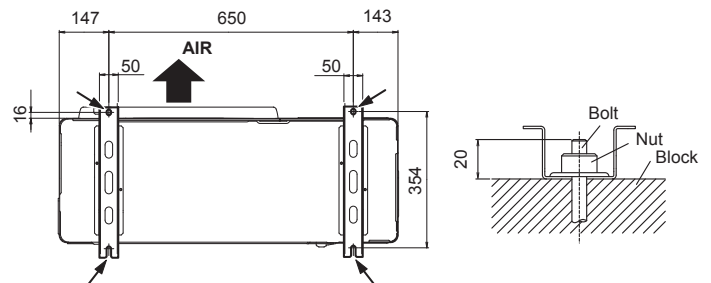

⚠ CAUTION

- Do not install the outdoor unit in two-stage where the drain water could freeze. Otherwise the drainage from the upper unit may form ice and cause a malfunction of the lower unit.
- When the outdoor temperature is 0 °C or less, do not use the accessory drain pipe. If the drain pipe is used, the drain water in the pipe may freeze in extremely cold climate.

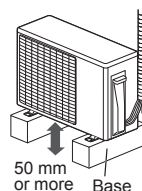

- If the unit is installed in a region that is exposed to high winds, freezing conditions, freezing rain, snow fall or heavy snow accumulation, take appropriate measures to protect it from those elements. To ensure stable operation, the outdoor unit must be installed on a raised stand or rack, at or above the anticipated snow depth for the region. The installation of snow hoods and drift prevention fencing is recommended when blowing and drifting snow is common to the region.

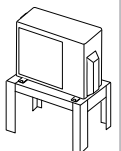

3.4. Drain installation

⚠ CAUTION

- Perform drain work in accordance with this Manual, and ensure that the drain water is properly drained. If the drain work is not carried out correctly, water may drip down from the unit, wetting the furniture.
- When the outdoor temperature is 0 °C or less, do not use the accessory drain pipe. If the drain pipe is used, the drain water in the pipe may freeze in extremely cold weather.

- If you are installing the drain pipe and drain caps, please provide a working space under the base of the outdoor unit.
- As the drain water flows out of the outdoor unit during heating operation, install the drain pipe and connect it to a commercial 16 mm hose. (Reverse cycle model only)
- When installing the drain pipe, plug all the holes other than the drain pipe mounting hole in the bottom of the outdoor unit with putty so there is no water leakage. (Reverse cycle model only)

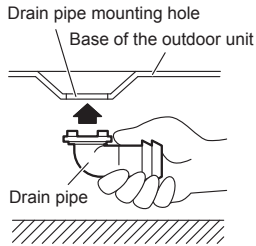

(Unit : mm)

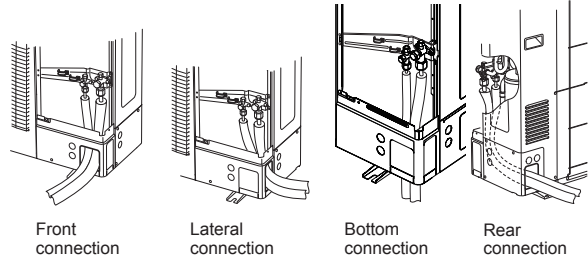
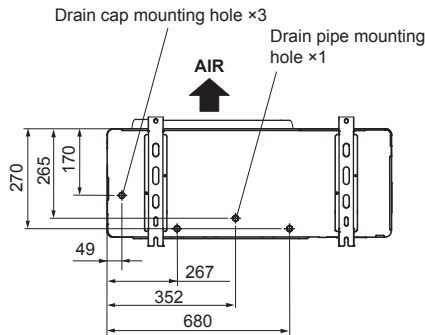
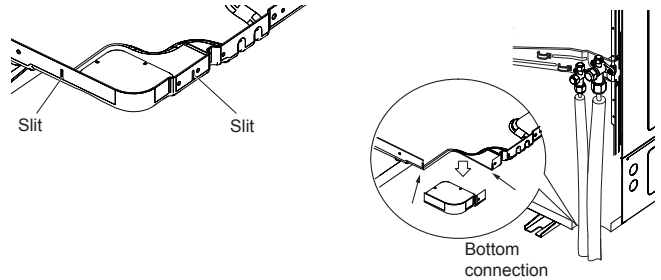

Fig. B

Fig. C



3.5. Pipe installation

3.5.1. Opening a knock out hole

⚠ CAUTION

- Be careful not to deform or scratch the panel while opening the knock out holes.
- To protect the piping insulation after opening a knock out hole, remove any burrs from the edge of the hole. It is recommended to apply rust prevention paint to the edge of the hole.

- Pipes can be connected from 4 directions, front, lateral side, rear side and bottom. (Fig. A)
- When connecting at the bottom, remove the service panel and piping cover on the front of the outdoor unit, and open the knock out hole provided at the bottom corner of the piping outlet.
- It can be installed as shown on "Fig. B" cutting out the 2 slits as indicated on "Fig. C". (When cutting slits, use a steel saw.)

Fig. A

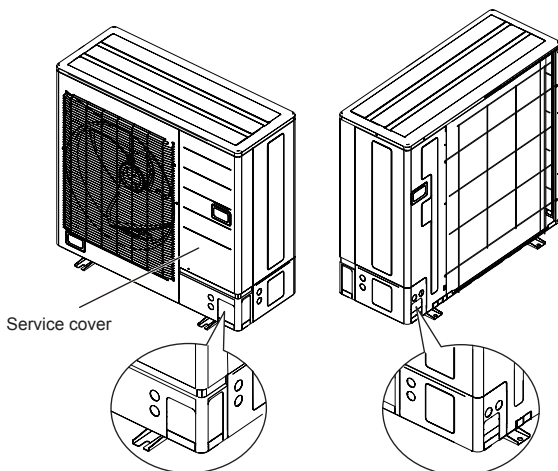

3.5.2. Pipe connection

■ Brazing

⚠ CAUTION

- If air or another type of refrigerant enters the refrigeration cycle, the internal pressure in the refrigeration cycle will become abnormally high and prevent the unit from exerting its full performance.
- Apply nitrogen gas while brazing the pipes. If a pipe is brazed without applying nitrogen gas, an oxidation film will be created. This can degrade performance or damage the parts in the unit (such as the compressor or valves). Nitrogen gas pressure: 0.02 MPa (= pressure felt sufficiently on the back of the hand)
- For brazing material, use phosphor copper that does not require flux. Do not use flux to braze pipes. If the flux is the chlorine type, it will cause the pipes to corrode. Furthermore, if the flux contains fluoride, it will adversely affect the refrigerant pipe system such as by degrading the refrigerant. If fluoride is contained, quality of refrigerant deteriorates and affects the refrigerant piping system.

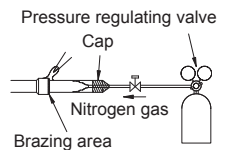

■ Flaring

⚠ CAUTION

Do not use mineral oil on a flared part. Prevent mineral oil from getting into the system as this would reduce the lifetime of the units.

- Use special pipe cutter and flare tool exclusive for R410A.
- (1) Cut the connection pipe to the necessary length with a pipe cutter.
- (2) Hold the pipe downward so that the cuttings will not enter the pipe and remove any burrs.
- (3) Insert the flare nut (always use the flare nut attached to the indoor and outdoor units respectively) onto the pipe and perform the flare processing with a flare tool. Leakage of refrigerant may result if other flare nuts are used.
- (4) Protect the pipes by pinching them or with tape to prevent dust, dirt, or water from entering the pipes.

Check if [L] is flared uniformly and is not cracked or scratched.

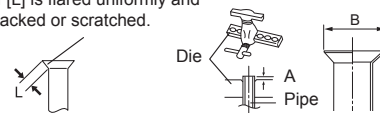

Pipe outside diameter [mm (in.)]	Dimension A [mm]	
	Flare tool for R410A, clutch type	Dimension B _{0.4} ⁰ [mm]
6.35 (1/4)	0 to 0.5	9.1
9.52 (3/8)		13.2
12.70 (1/2)		16.6
15.88 (5/8)		19.7
19.05 (3/4)		24.0

- When using conventional flare tools to flare R410A pipes, the dimension A should be approximately 0.5 mm more than indicated in the table (for flaring with R410A flare tools) to achieve the specified flaring. Use a thickness gauge to measure the dimension A.

Width across flats



Pipe outside diameter [mm (in.)]	Width across flats of Flare nut [mm]
6.35 (1/4)	17
9.52 (3/8)	22
12.70 (1/2)	26
15.88 (5/8)	29
19.05 (3/4)	36

Bending pipes

CAUTION

- To prevent breaking of the pipe, avoid sharp bends. Bend the pipe with a radius of curvature of 100 mm to 150 mm.
- If the pipe is bent repeatedly at the same place, it will break.

- If pipes are shaped by hand, be careful not to collapse them.
- Do not bend the pipes at an angle of more than 90°.
- When pipes are repeatedly bent or stretched, the material will harden, making it difficult to bend or stretch them anymore.
- Do not bend or stretch the pipes more than three times.

Connecting pipes

CAUTION

- Be sure to install the pipe against the port on the indoor unit and the outdoor unit correctly. If the centering is improper, the flare nut cannot be tightened smoothly. If the flare nut is forced to turn, the threads will be damaged.
- Do not remove the flare nut from the outdoor unit pipe until immediately before connecting the connection pipe.
- After installing the piping, make sure that the connection pipes do not touch the compressor or outer panel. If the pipes touch the compressor or outer panel, they will vibrate and produce noise.

- Detach the caps and plugs from the pipes.
- Center the pipe against the port on the outdoor unit, and then turn the flare nut by hand.
- Tighten the flare nut of the connection pipe at the outdoor unit valve connector.

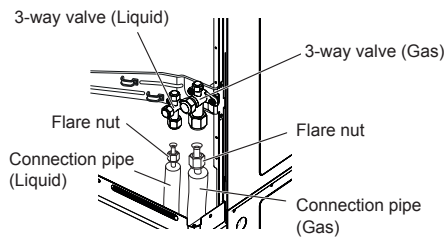

- After tightening the flare nut by hand, use a torque wrench to fully tighten it.

CAUTION

- Hold the torque wrench at its grip, keeping it in a right angle with the pipe, in order to tighten the flare nut correctly.
- Fasten a flare nut with a torque wrench as instructed in this manual. If fastened too tight, the flare nut may be broken after a long period of time and cause a leakage of refrigerant.

- Outer panel may be distorted if fastened only with a wrench. Be sure to fix the elementary part with a spanner and fasten with a wrench. (Refer to the following figure.)
- Do not apply force to the blank cap of the valve or hang a wrench, etc., on the cap. It may cause leakage of refrigerant.

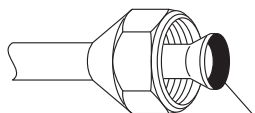
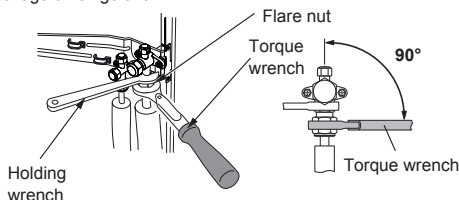

To prevent gas leakage, coat the flare surface with refrigerant oil.

Flare nut [mm (in.)]	Tightening torque [N·m (kgf·cm)]
6.35 (1/4) dia.	16 to 18 (160 to 180)
9.52 (3/8) dia.	32 to 42 (320 to 420)
12.70 (1/2) dia.	49 to 61 (490 to 610)
15.88 (5/8) dia.	63 to 75 (630 to 750)
19.05 (3/4) dia.	90 to 110 (900 to 1100)

Handling precautions for the valves

- Mounted part of blank cap is sealed for protection.
- Fasten blank cap tightly after opening valves.

Table A

Blank cap [mm (in.)]	Tightening torque [N·m (kgf·cm)]
6.35 (1/4)	20 to 25 (200 to 250)
9.52 (3/8)	20 to 25 (200 to 250)
12.70 (1/2)	28 to 32 (280 to 320)
15.88 (5/8)	30 to 35 (300 to 350)
19.05 (3/4)	35 to 40 (350 to 400)

Operating the valves

- Use a hexagon wrench (size 4 mm).
- Opening
 - Insert the hexagon wrench into the valve shaft, and turn it counterclockwise.
 - Stop turning when the valve shaft can no longer be turned. (Open position)
- Closing
 - Insert the hexagon wrench into the valve shaft, and turn it clockwise.
 - Stop turning when the valve shaft can no longer be turned. (Closed position)

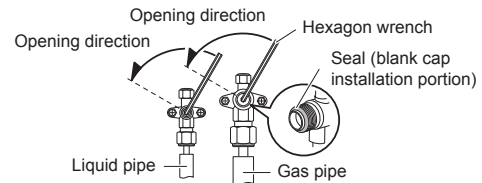

3.6. Sealing test

WARNING

- Before operating the compressor, install the pipes and securely connect them. Otherwise, if the pipes are not installed and if the valves are open when the compressor operates, air could enter the refrigeration cycle. If this happens, the pressure in the refrigeration cycle will become abnormally high and cause damage or injury.
- After the installation, make sure there is no refrigerant leakage. If the refrigerant leaks into the room and becomes exposed to a source of fire such as a fan heater, stove, or burner, it produces a toxic gas.
- Do not subject the pipes to strong shocks during the sealing test. It can rupture the pipes and cause serious injury.

CAUTION

- Do not block the walls and the ceiling until the sealing test and the charging of the refrigerant gas have been completed.
- For maintenance purposes, do not bury the piping of the outdoor unit.

After connecting the pipes, perform a sealing test.

- Make sure that the 3-way valves are closed before performing a sealing test.
- Pressurize nitrogen gas to 4.15 MPa to perform the sealing test.
- Add nitrogen gas to both the liquid pipes and the gas pipes.
- Check all flared and brazed connections. Then, check that the pressure has not decreased.
- Compare the pressures after pressurizing and letting it stand for 24 hours, and check that the pressure has not decreased.
 - * When the outdoor air temperature changes 5 °C, the test pressure changes 0.05 MPa. If the pressure has dropped, the pipe joints may be leaking.
- If a leak is found, immediately repair it and perform the sealing test again.
- After completing the sealing test, release the nitrogen gas from both valves.
- Release the nitrogen gas slowly.

3.7. Vacuum process

⚠ CAUTION

- Perform a refrigerant leakage test (air tightness test) to check for leaks using nitrogen gas while all valves in the outdoor unit are closed. (Use the test pressure indicated on the nameplate.)
- Be sure to evacuate the refrigerant system using a vacuum pump.
- The refrigerant pressure may sometimes not rise when a closed valve is opened after the system is evacuated using a vacuum pump. This is caused by the closure of the refrigerant system of the outdoor unit by the electronic expansion valve. This will not affect the operation of the unit.
- If the system is not evacuated sufficiently, its performance will drop.
- Use a clean gauge manifold and charging hose that were designed specifically for use with R32(R410A). Using the same vacuum equipment for different refrigerants may damage the vacuum pump or the unit.
- Do not purge the air with refrigerants, but use a vacuum pump to evacuate the system.

Refrigerant for purging the air is not charged in the outdoor unit at the factory.

- (1) Remove the cap, and connect the gauge manifold and the vacuum pump to the charging valve by the service hoses.
- (2) Vacuum the indoor unit and the connecting pipes until the pressure gauge indicates -0.1 MPa (-76 cmHg).
- (3) When -0.1 MPa (-76 cmHg) is reached, operate the vacuum pump for at least 60 minutes.
- (4) Disconnect the service hoses and fit the cap to the charging valve to the specified torque.
- (5) Remove the blank caps, and fully open the spindles of the 3-way valves with a hexagon wrench [Torque: 6~7 N·m (60 to 70 kgf·cm)].
- (6) Tighten the blank caps of the 3-way valves to the specified torque.

		Tightening torque
Blank cap	6.35 mm (1/4 in.)	20 to 25 N·m (200 to 250 kgf·cm)
	9.52 mm (3/8 in.)	20 to 25 N·m (200 to 250 kgf·cm)
	12.70 mm (1/2 in.)	28 to 32 N·m (280 to 320 kgf·cm)
	15.88 mm (5/8 in.)	30 to 35 N·m (300 to 350 kgf·cm)
	19.05 mm (3/8 in.)	35 to 40 N·m (350 to 400 kgf·cm)
Charging port cap		12.5 to 16 N·m (125 to 160 kgf·cm)

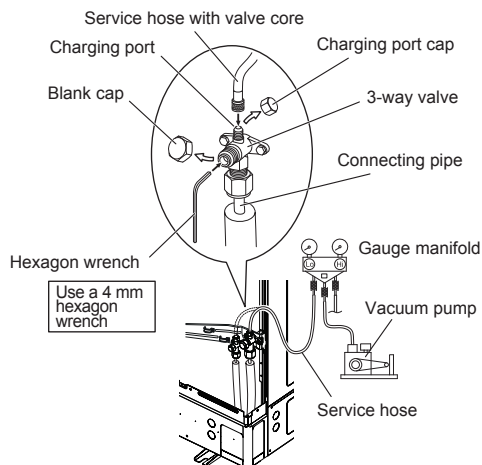

3.8. Electrical wiring

⚠ WARNING

- Wiring connections must be performed by a qualified person in accordance with the specifications. The voltage rating for this product is 230 V at 50 Hz. It should be operated within the range of 198 to 264 V. The voltage rating for the three-phase product is 400 V at 50 Hz. It should be operated within the range of 342 to 456 V.
- Before connecting the wires, make sure the power supply is off.
- Never touch electrical components immediately after the power supply has been turned off. Electrical shock may occur. After turning off the power, always wait 10 minutes or more before touching electrical components.
- Use a dedicated power supply circuit. Insufficient power capacity in the electrical circuit or improper wiring may cause electric shock or fire.
- Be sure to install an earth leakage breaker. Otherwise, it will cause electric shock or fire.
- A circuit breaker is installed in the permanent wiring. Always use a circuit that can trip all the poles of the wiring and has an isolation distance of at least 3 mm between the contacts of each pole.
- Use designated cables and power cables. Improper use may cause electric shock or fire by poor connection, insufficient insulation, or over current.
- Do not modify power cable, use extension cable or branch wiring. Improper use may cause electric shock or fire by poor connection, insufficient insulation or over current.
- Connect the connector cable securely to the terminal. Check no mechanical force bears on the cables connected to the terminals. Faulty installation can cause a fire.
- Use ring terminals and tighten the terminal screws to the specified torques, otherwise, abnormal overheating may be produced and possibly cause serious damage inside the unit.
- Make sure to secure the insulation portion of the connector cable with the cable clamp. Damaged insulation can cause a short circuit.
- Fix cables so that cables do not make contact with the pipes (especially on high pressure side). Do not make power supply cable and transmission cable come in contact with valves (Gas).
- Never install a power factor improvement condenser. Instead of improving the power factor, the condenser may overheat.
- Be sure to perform the grounding work. Do not connect grounding wires to a gas pipe, water pipe, lightning rod or grounding wire for a telephone.
 - Connection to a gas pipe may cause a fire or explosion if gas leaks.
 - Connection to a water pipe is not an effective grounding method if PVC pipe is used.
 - Connection to the grounding wire of a telephone or to a lightning rod may cause a dangerously abnormal rise in the electrical potential if lightning strikes.
 - Improper grounding work can cause electric shocks.
- Securely install the electrical box cover on the unit. An improperly installed service panel can cause serious accidents such as electric shock or fire through exposure to dust or water.
- Do not connect the AC power supply to the transmission line terminal board. Improper wiring can damage the entire system.

CAUTION

- The primary power supply capacity is for the air conditioner itself, and does not include the concurrent use of other devices.
- If the electrical power is inadequate, contact your electric power company.
- Install a breaker in a location that is not exposed to high temperatures. If the temperature surrounding the breaker is too high, the amperage at which the breaker cuts out may decrease.
- When using an earth leakage breaker that has been designed solely for ground fault protection, be sure to install a fuse-equipped switch or circuit breaker.
- This system uses an inverter, which means that it must be used an earth leakage breaker that can handle harmonics in order to prevent malfunctioning of the earth leakage breaker itself.
- Do not use crossover power supply wiring for the outdoor unit.
- If the temperature surrounding the breaker is too high, the amperage at which the breaker cuts out may decrease.
- When the electrical switchboard is installed outdoors, place it under lock and key so that it is not easily accessible.
- Start wiring work after closing branch switch and over current breaker.
- Connection cable between indoor unit and outdoor unit is 230 V (single-phase) or 400 V (three-phase).
- Be sure not to remove thermistor sensor etc. from power wiring and connection wiring. Compressor may fail if operated while removed.
- Do not fasten the power supply cable and connection cable together.
- Always keep to the maximum length of the connection cable. Exceeding the maximum length may lead to erroneous operation.
- Do not start operation until the refrigerant is charged completely. The compressor will fail if it is operated before the refrigerant piping charging is complete.
- The static electricity that is charged to the human body can damage the control PC Board when handling the control PC Board for address setting, etc. Please keep caution to the following points. Provide the grounding of Indoor unit, Outdoor unit and Option equipment. Cut off the power supply (breaker). Touch the metal section (such as the unpainted control box section) of the indoor or outdoor unit for more than 10 seconds. Discharge the static electricity in your body. Never touch the component terminal or pattern on the PC Board.
- Be careful not to generate a spark as follows for using a flammable refrigerant.
 - Do not remove the fuse while power is on.
 - Do not disconnect plug from the wall outlet and the wiring while the power is on.
 - It is recommended to position the outlet connection in a high position. Place the cords so that they do not get tangled.
- Confirm the indoor unit model name before connecting. If the indoor unit is not R32 compatible, error signal will be displayed, and the unit will be inoperable.

3.8.1. How to connect wiring to the terminal

Caution when wiring cable

- When stripping off the coating of a lead wire, always use a special tool such as a wire stripper. If there is no special tool available, carefully strip the coating with a knife etc.
- (1) Use ring terminals with insulating sleeves as shown in the figure below to connect to the terminal block.
 - (2) Securely clamp the ring terminals to the wires using an appropriate tool so that the wires do not come loose.

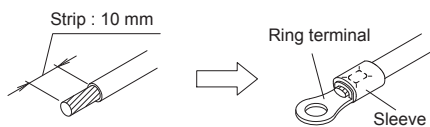

- (3) Use the specified wires, connect them securely, and fasten them so that there is no stress placed on the terminals.
- (4) Use an appropriate screwdriver to tighten the terminal screws. Do not use a screwdriver that is too small, otherwise, the screw heads may be damaged and prevent the screws from being properly tightened.
- (5) Do not tighten the terminal screws too much, otherwise, the screws may break.

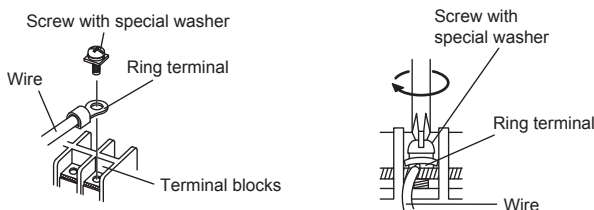

- (6) Refer to the table below for the terminal screw tightening torques.

Tightening torque [N·m (kgf·cm)]	
M4 screw	1.2 to 1.8 (12 to 18)
M5 screw	2.0 to 3.0 (20 to 30)

3.8.2. Knock out holes for wiring

CAUTION

- Be careful not to deform or scratch the panel while opening the knock out holes.
 - When cables are routed from the unit, a protection sleeve for the conduits can be inserted at the knock out hole.
 - If you do not use a wire conduit, be sure to protect the wires to prevent the edge of the knock out hole from cutting the wires.
 - It is recommended to apply anti-rust paint to the edge of the knock out hole.
- Knock out holes are provided 2 each in the same size in front, lateral and rear sides.

Installation method of One-touch bush

Please fix the one-touch bush (accessory) as shown below.

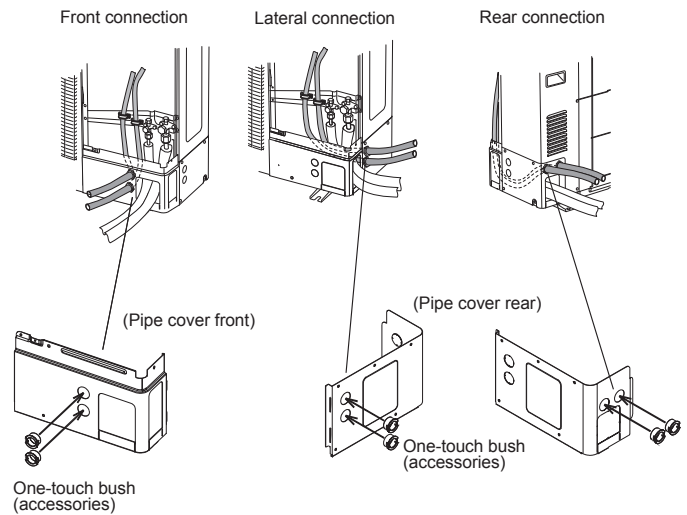

NOTES: Please ensure that the power supply cable and connection cables are not installed through the same cable bush hole opening. They must be installed into the two separate hole openings to prevent damage to the cable.

3.8.3. Wiring method

CAUTION

When connecting the power supply cable, make sure that the phase of the power supply matches with the phase of the terminal board. If the phases do not match, the compressor will rotate in reverse and will not be able to compress.

Connection diagrams

Single phase type

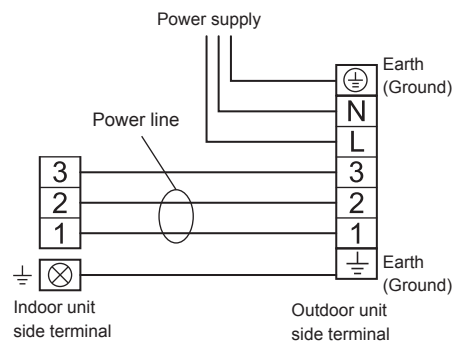

Three phase type

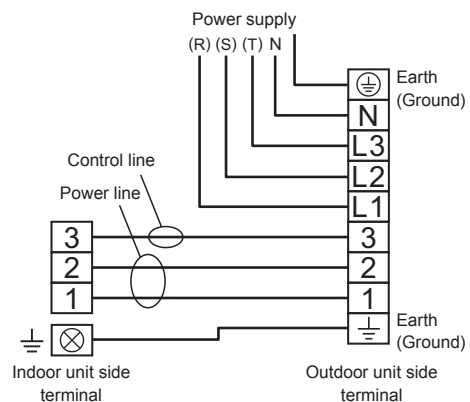

■ Cable preparation

- Keep the earth (ground) wire longer than the other wires.

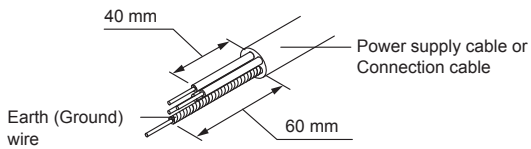

■ Wiring procedure

- (1) • Remove the tapping screws. (2 places)
- Remove the service cover by pushing downwards.

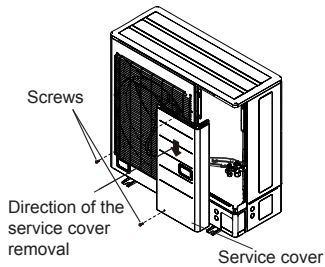

- (2) Connect the power supply cable and the connection cable to terminal.
- (3) Fasten the power supply cable and connection cable with cable clamp.

Single phase type

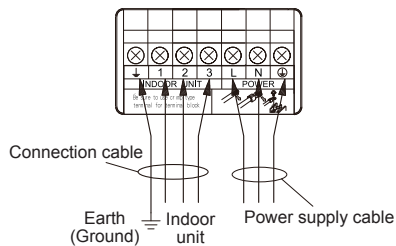
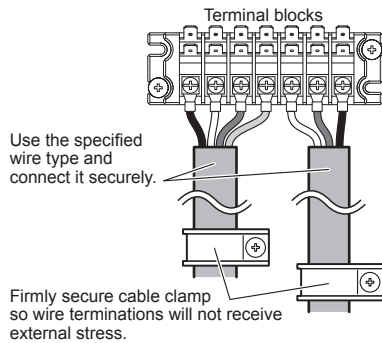

Three phase type

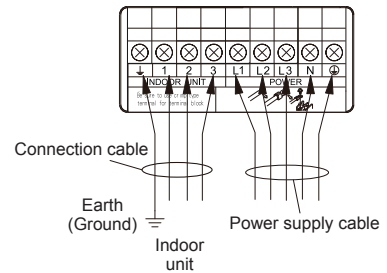
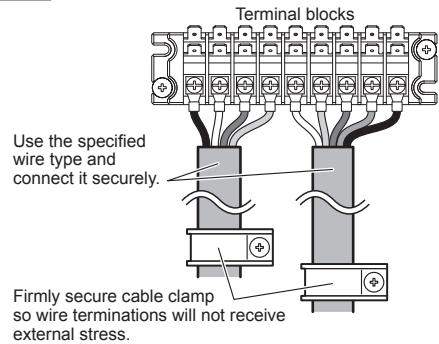

- (4) Secure the cables using the cable clamp attached to the base of the valves.

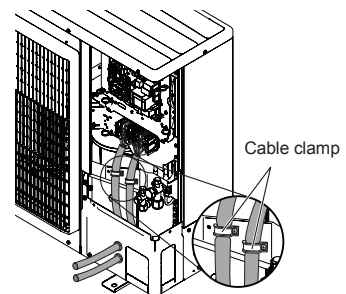

- (5) Put the service cover back after completion of the work. Replace the tapping screws. (2 places)

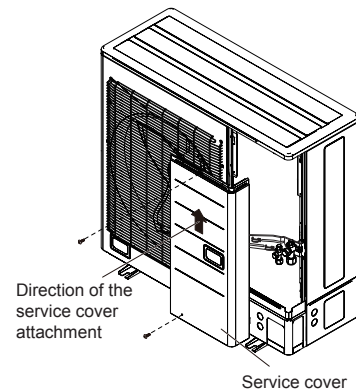

4. TEST RUN

4.1. Pre-test run check items

Check items

<input type="checkbox"/>	Is the outdoor unit securely installed?
<input type="checkbox"/>	Have you performed gas leakage inspection? (Connection joints of various pipes (flange connection, brazing))
<input type="checkbox"/>	Is the heat insulation done completely? (Gas pipe, liquid pipe, drain hose extension on indoor unit side etc.)
<input type="checkbox"/>	Is the water discharging from drain without any problems?
<input type="checkbox"/>	Are the cables connected correctly?
<input type="checkbox"/>	Are the cables as per specifications?
<input type="checkbox"/>	Is the earth (ground) wire connected accurately?
<input type="checkbox"/>	Are there any obstacles blocking the suction gate, and outlet of the indoor/outdoor units?
<input type="checkbox"/>	Have you filled the specified amount of refrigerant?
<input type="checkbox"/>	Are the stop valves of gas pipe and liquid pipe fully open?
<input type="checkbox"/>	Has the power been supplied to crankcase heater for more than 6 hours?

After checking that the above items are all in order, refer to "4.2. Test operation method" to test operation the unit. If there are problems, adjust immediately and recheck.

4.2. Test operation method

Be sure to configure test run settings only when the outdoor unit has stopped operating.

- Depending on the communication status between the indoor and outdoor units, it may take several minutes for the system to start operating after settings for the test run are complete.
- After the test run settings are complete, the outdoor units and the connected indoor units will start operating. Room temperature control will not activate during test operation (continuous operation).
- If a knocking sound can be heard in the liquid compression of the compressor, stop the unit immediately and then energize the crank case heater for a sufficient length of time before restarting the operation.

Test operation setting method (It can be performed in the following two ways)

- Set with test operation setting (refer to the installation manual of indoor unit for further details) available in the remote controller.
- Cooling operation and Heating operation can be set using [SELECT] button (S133) and [ENTER] button (S132) available on the board of display unit. (Make sure to perform the first test operation with cooling operation.) Set as per the following procedure.

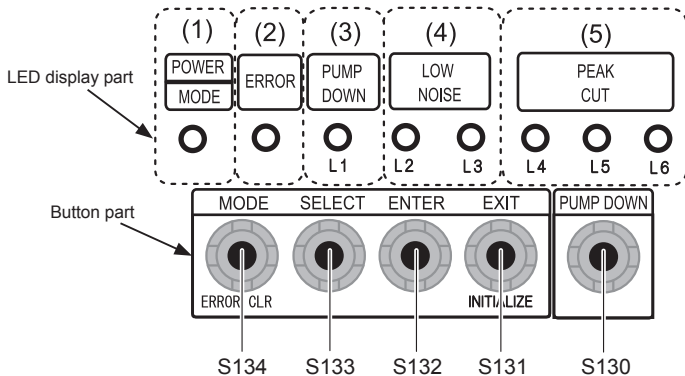

4.2.1. Setting method on outdoor unit board

- Turn on the power of the outdoor unit and enter standby mode. "POWER/MODE" display lights on.

POWER/MODE	ERROR	PUMP DOWN (L1)	LOW NOISE (L2) (L3)		PEAK CUT (L4) (L5) (L6)		
●	○	○	○	○	○	○	○

Sign "○": Lights off, "●": Lights on

- Press the [ENTER] button (S132) for more than 3 seconds.

POWER/MODE	ERROR	PUMP DOWN (L1)	LOW NOISE (L2) (L3)		PEAK CUT (L4) (L5) (L6)		
Blink	○	○	○	Blink	○	○	○

Sign "○": Lights off, "●": Lights on

- Press the [SELECT] button (S133), LED of the test run mode switched between Cooling and Heating.
Cooling test mode

POWER/MODE	ERROR	PUMP DOWN (L1)	LOW NOISE (L2) (L3)		PEAK CUT (L4) (L5) (L6)		
Blink	○	○	○	Blink	○	○	○

Sign "○": Lights off, "●": Lights on

Heating test mode

POWER/MODE	ERROR	PUMP DOWN (L1)	LOW NOISE (L2) (L3)		PEAK CUT (L4) (L5) (L6)		
Blink	○	○	Blink	○	○	○	○

Sign "○": Lights off, "●": Lights on

- After confirming the operation mode, press [ENTER] button (S132). The display changes as follows, and the air conditioner starts operation.
Cooling test mode

POWER/MODE	ERROR	PUMP DOWN (L1)	LOW NOISE (L2) (L3)		PEAK CUT (L4) (L5) (L6)		
Blink	○	○	○	●	○	○	○

Sign "○": Lights off, "●": Lights on

Heating test mode

POWER/MODE	ERROR	PUMP DOWN (L1)	LOW NOISE (L2) (L3)		PEAK CUT (L4) (L5) (L6)		
Blink	○	○	●	○	○	○	○

Sign "○": Lights off, "●": Lights on

- Press [ENTER] button (S132).
Air conditioner stops operation.

POWER/MODE	ERROR	PUMP DOWN (L1)	LOW NOISE (L2) (L3)		PEAK CUT (L4) (L5) (L6)		
●	○	○	○	○	○	○	○

Sign "○": Lights off, "●": Lights on

4.3. Checklist

Check items during test operation.

<input type="checkbox"/>	Is the outdoor unit making any abnormal noise or vibrating significantly?
<input type="checkbox"/>	Is the cold air or hot air blowing from indoor unit according to the operation mode?
<input type="checkbox"/>	Check that the "ERROR" LED blinks. If, it has displayed, check the error content as per the "10.2. Error code check table" described later.
<input type="checkbox"/>	Operate the unit according to the operating manual provided with the indoor unit, and check that it is operating normally.

5. FINISHING

⚠ WARNING

Install the insulated pipes so that they do not touch the compressor.

5.1. Installing insulation

- Install insulation material after conducting "3.6. Sealing test".
- To prevent condensation and water droplets, install insulation material on the refrigerant pipe. (Fig. A)
- Refer to the table to determine the thickness of the insulation material.

Selection of insulation

(Use an insulation material with equal heat transmission rate or below 0.040 W/(m·k))

		Insulation material minimum thickness (mm)			
		≤ 70%	≤ 75%	≤ 80%	≤ 85%
Pipe diameter (mm)	6.35	8	10	13	17
	9.52	9	11	14	18
	12.70	10	12	15	19
	15.88	10	12	16	20
	19.05	10	13	16	21
	22.22	11	13	17	22
	25.40	11	13	17	22

* When the ambient temperature and relative humidity exceed 32 °C (DB) and 85% respectively, please strengthen the heat insulation of refrigerant pipe.

5.2. Filling with putty

⚠ WARNING

Fill the piping holes and wiring holes with putty (locally purchased) to avoid any gap (Fig. A). If small animals such as insects enter the external unit, a short circuit may be caused near electrical components in the service panel.

- If the outdoor unit is installed at a level that is higher than the indoor unit, the water that has condensed in the 3-way valve of the outdoor unit could travel to the indoor unit. Therefore, use putty in the space between the pipe and the insulation to prevent the entry of water to the indoor units.

Fig. A

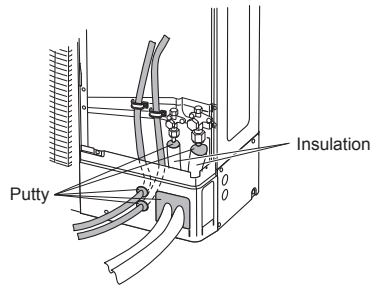

6. HOW TO OPERATE DISPLAY UNIT

6.1. Display unit position

⚠ WARNING

Never touch electrical components such as the terminal blocks except the button on the display board. It may cause a serious accident such as electric shock.

⚠ CAUTION

- Once refrigerant charging is completed, be sure to open the valve prior to performing the local settings. Otherwise, the compressor may fail.
- Discharge any static electricity from your body before touching the push buttons. Never touch any terminal or pattern of any parts on the control board.
- The positions of the buttons on the outdoor unit control board are shown in the following figure.
- Various settings can be adjusted by changing push buttons on the board of the outdoor unit.

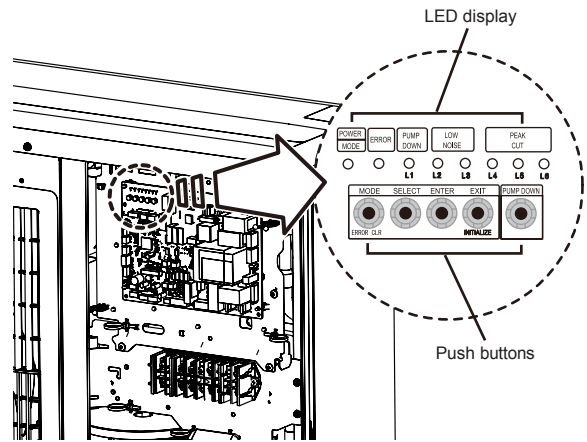

6.2. Description of display and buttons

- The printed characters for the LED display are shown below.

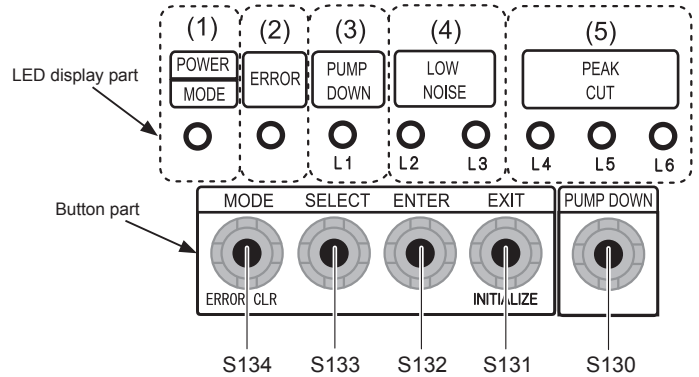

Display lamp		Function or operation method
(1) POWER / MODE	Green	Lights on while power on. Local setting in outdoor unit or error code is displayed with blink.
(2) ERROR	Red	Blinks during abnormal air conditioner operation.
(3) PUMP DOWN (L1)	Orange	Lights on during pump down operation.
(4) LOW NOISE (L2, L3)	Orange	Lights on during Low noise mode when local setting is activated. (Lighting pattern of L2 and L3 indicates low noise level) *Refer to the page 14.
(5) PEAK CUT (L4, L5, L6)	Orange	Lights on during Peak cut mode when local setting is activated. (Lighting pattern of L4, L5 and L6 indicates peak cut level) *Refer to the page 15.

Button		Function or operation method
S134	MODE	To switch between "Local setting" and "Error code display".
S133	SELECT	To switch between the individual "Local settings" and the "Error code displays".
S132	ENTER	To fix the individual "Local settings" and the "Error code displays".
S131	EXIT	To return to "Operation status displays."
S130	PUMP DOWN	To start the pump down operation.

7. FIELD SETTING

CAUTION

- Discharge the static electricity from your body before setting up the switches.
- Never touch the terminals or the patterns on the parts that are mounted on the board.

7.1. Field setting buttons

- Remove the front panel of the outdoor unit to access the print circuit board of the display unit.
Print circuit board buttons for various settings and LED displays are shown in the figure.

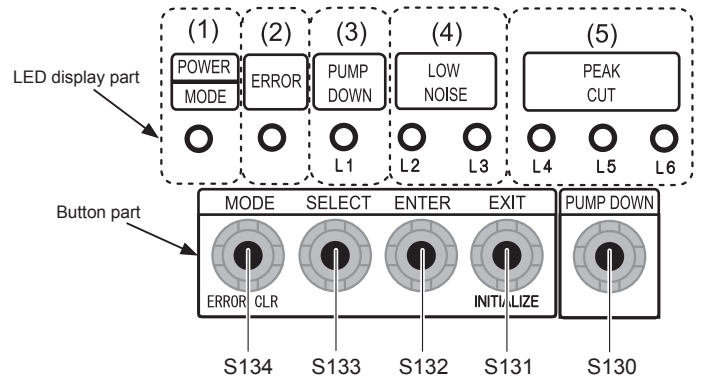

7.2. Function settings

- Various functions can be set. Follow the setting method described in 7.2.1. and 7.2.2. to set as per the requirement.
Perform these settings after the indoor unit stops.

Table. Settings List

No	Setting Item	LED display									Factory setting	Content	
		POWER/MODE	ERROR	PUMP DOWN (L1)	LOW NOISE (L2) (L3)			PEAK CUT (L4) (L5) (L6)					
1	Low noise mode setting	Level 1	Blink (9 times)	○	○	○	●	○	○	○	●	◆	By using the "Low noise mode", the limit of the noise level will be set to decrease the noise level. The mode comes in 2 levels which can be set accordingly. To turn on the mode, use the external input connector (P580). *By using this mode, the cooling/heating performance may decrease. *Depending on the operating condition, the noise level may not decrease even if the Low noise mode is on.
		Level 2	Blink (9 times)	○	○	○	●	○	●	○	○		
2	Peak cut mode setting	Level 1	Blink (9 times)	○	○	●	○	○	○	○	●		The capacity limit can be selected when operating with the Peak cut mode. The operation selection can be done by external input connector (PA580). The lower the level, the more the effect of energy saving, but the cooling/heating performance decreases.
		Level 2	Blink (9 times)	○	○	●	○	○	●	○			
		Level 3	Blink (9 times)	○	○	●	○	○	●	●			
		Level 4	Blink (9 times)	○	○	●	○	●	○	○	◆		

Sign "○": Lights off, "●": Lights on

7.2.1. Setting for Low noise mode

- (1) Switch to "Local setting mode" by pressing [MODE] button (S134) for 3 seconds or more.
- (2) Confirm (POWER / MODE) blinks 9 times, and press [ENTER] button (S132).

POWER/MODE	ERROR	PUMP DOWN (L1)	LOW NOISE (L2) (L3)			PEAK CUT (L4) (L5) (L6)		
Blink (9 times)	○	○	○	○	○	○	○	○

Sign "○": Lights off, "●": Lights on, () : Number of blinking

- (3) Press [SELECT] button (S133), and adjust LED display as shown below. (Current setting is displayed)

LOW NOISE	
(L2)	(L3)
LOW NOISE MODE	○
	Blink

Sign "○": Lights off

- (4) Press [ENTER] button (S132).

LOW NOISE	
(L2)	(L3)
LOW NOISE MODE	○
	●

Sign "○": Lights off, "●": Lights on

- (5) Press [SELECT] button (S133), and adjust LED display as shown in below figure.

PEAK CUT		
(L4)	(L5)	(L6)
Level 1	○	○
Level 2	○	Blink

Sign "○": Lights off

The noise of Level 2 is lower than the one of Level 1.

- (6) Press [ENTER] button (S132) and fix it.

		PEAK CUT		
		(L4)	(L5)	(L6)
Level 1		○	○	●
Level 2		○	●	○

Sign "○": Lights off, "●": Lights on

- (7) Return to "Operating status displays" (normal operation) by pressing [EXIT] button (S131).

- In case of missing how many times [SELECT] and [ENTER] buttons are pressed, restart from the beginning of operation procedure after returning to "Operation status displays" (normal operation) by pressing the [EXIT] button (S131) once.

7.2.2. Setting for Peak cut mode

- Switch to "Local setting mode" by pressing [MODE] button (S134) for 3 seconds or more.
- Confirm (POWER / MODE) blinks 9 times, and press [ENTER] button (S132).

POWER/ MODE	ERROR	PUMP DOWN (L1)	LOW NOISE		PEAK CUT		
			(L2)	(L3)	(L4)	(L5)	(L6)
Blink (9 times)	○	○	○	○	○	○	○

Sign "○": Lights off, "●": Lights on, () : Number of blinking

- Press [SELECT] button (S133), and adjust LED display as shown below. (Current setting is displayed)

		LOW NOISE	
		(L2)	(L3)
PEAK CUT MODE	Blink	○	

Sign "○": Lights off

- Press [ENTER] button (S132).

		LOW NOISE	
		(L2)	(L3)
PEAK CUT MODE	●	○	

Sign "○": Lights off, "●": Lights on

- Press [SELECT] button (S133), and adjust LED display as shown in below figure.

		PEAK CUT		
		(L4)	(L5)	(L6)
Level 1	0% of rated input ratio	○	○	Blink
Level 2	50% of rated input ratio	○	Blink	○
Level 3	75% of rated input ratio	○	Blink	Blink
Level 4	100% of rated input ratio	Blink	○	○

Sign "○": Lights off

- Press [ENTER] button (S132) and fix it.

		PEAK CUT		
		(L4)	(L5)	(L6)
Level 1	0% of rated input ratio	○	○	●
Level 2	50% of rated input ratio	○	●	○
Level 3	75% of rated input ratio	○	●	●
Level 4	100% of rated input ratio	●	○	○

Sign "○": Lights off, "●": Lights on

- Return to "Operating status displays" (normal operation) by pressing [EXIT] button (S131).

- When pressed number is lost during operation, restart from the beginning of operation procedure after returning to "Operation status displays" (normal operation) by pressing the [EXIT] button once.

8. EXTERNAL INPUT AND OUTPUT

8.1. External input

8.1.1. Wiring of connector

On/Off of the "Low noise mode" and "Peak cut mode" functions can be enabled with an external field device.

When installing connection cable, specified part (optional parts) must be used.

Refer to section 7.2. "Table. Settings List", for the required function. The function must be set for the external input to work.

Input	Connector
Low noise mode	P580
Peak cut mode	PA580

* Make the distance from the PC board to the connected unit within 10m (33ft).

* Contact capacity : 24VDC or more, 10mA or more.

Circuit diagram example

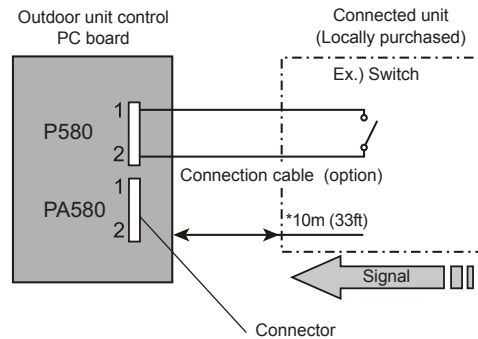

8.1.2. Low noise mode (P580)

This feature reduces the operating sound of the outdoor unit from the normal sound.

The air conditioner is set to Low noise mode when closing the contact input of a commercial timer or On/Off switch to a connector on the outdoor control PC board.

* Performance may drop depending on the outside air temperature condition, etc.

* Set the "Low noise mode" level, refer to "7.2. Function settings".

Input Signal ...On : Low noise mode

...Off : Normal operation

Input Signal

On

Off

Low noise mode

On

Off

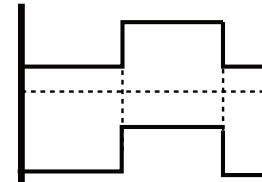

8.1.3. Peak cut mode (PA580)

Operation that suppressed the current value can be performed by means of the connected unit. The air conditioner is set to the Peak cut mode by applying the contact input of a commercial On/Off switch to a connector on the outdoor control PC board.

* Set the "Peak cut mode" level, refer to "7.2. Function settings".

Input Signal ...On : Peak cut mode

...Off : Normal operation

Input Signal

On

Off

Peak cut mode

On

Off

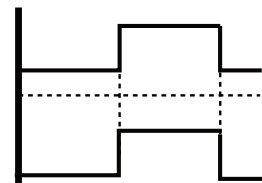

8.2. External output

8.2.1. Wiring of connector

When installing connection cable, specified part (optional parts) must be used.

Output	Connector
Error status	P590
Compressor status	PA590

* Make the distance from the PC board to the connected unit within 10m (33ft).

Load

- Load : DC 50mA or less is recommended

Circuit diagram example

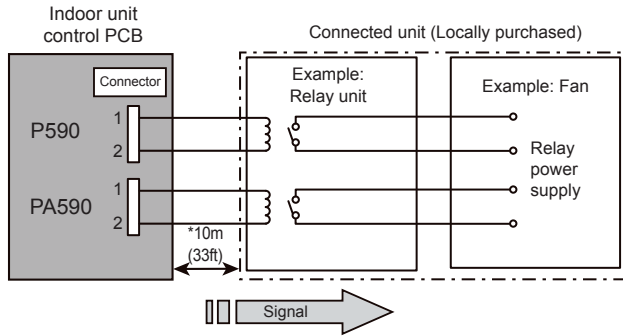

8.2.2. Error status output (P590)

An air conditioner error status signal is produced when a malfunction occurs.

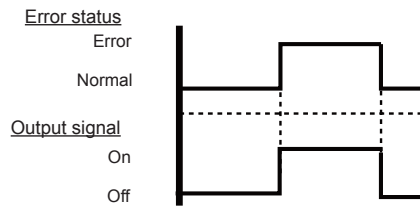

8.2.3. Compressor status output (PA590)

Compressor operation status signal is produced when the compressor is running.

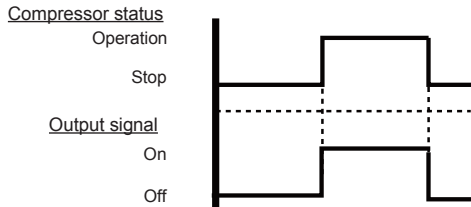

9. PUMP DOWN

⚠ WARNING

- Never touch electrical components such as the terminal blocks except the button on the display board. It may cause a serious accident such as electric shock.
- During the pump down operation, make sure that the compressor is turned off before you remove the refrigerant piping. Do not remove the connection pipe while the compressor is in operation with 2-way or 3-way valve open. This may cause abnormal pressure in the refrigeration cycle that leads to breakage and even injury.

⚠ CAUTION

- Perform the pump down operation before disconnecting any refrigerant pipe or electric cable.
- Collect refrigerant from the service port or the 3-way valve if pump down cannot be performed.
- In case of a group control system installation, do not turn the power off until the pump down is completed in all outdoor units. (Group control system installation described in "SPECIAL INSTALLATION METHODS" in the installation manual of the indoor unit.)

- Operate [PUMP DOWN] button (S130) on the display board with the following procedure.

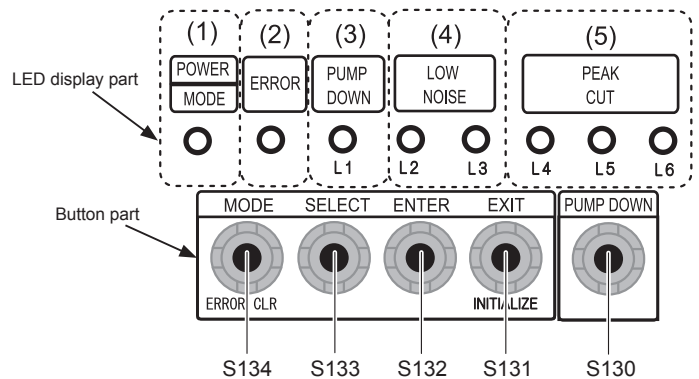
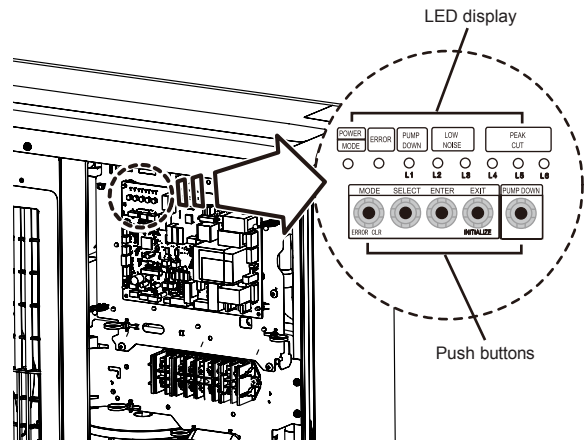

9.1. Preparation for pump down

- Confirm that the power is off, and then open the service panel.

9.2. Pump down procedure

- Check the 3-way valves (both the liquid side and gas side) are opened.
- Turn the power on.

POWER/ MODE	ERROR	PUMP DOWN (L1)	LOW NOISE			PEAK CUT		
			(L2)	(L3)	(L4)	(L5)	(L6)	
●	○	○	○	○	○	○	○	○

Sign "○": Lights off, "●": Lights on

- Press [PUMP DOWN] button (S130) for 3 seconds or more after 3 minutes after power on.

POWER/ MODE	ERROR	PUMP DOWN (L1)	LOW NOISE			PEAK CUT		
			(L2)	(L3)	(L4)	(L5)	(L6)	
●	○	●	○	○	●	●	●	

Sign "○": Lights off, "●": Lights on

LED display lights on as shown in the above table, and the fans and the compressor start operating.

- If the [PUMP DOWN] button (S130) is pressed while the compressor is operating, the compressor will stop, then start again in about 3 minutes.
- LED display will change as shown below about 3 minutes after the compressor starts. Fully close the 3-way valve on the liquid pipe side at this stage.

POWER/ MODE	ERROR	PUMP DOWN (L1)	LOW NOISE			PEAK CUT		
			(L2)	(L3)	(L4)	(L5)	(L6)	
●	○	●	○	○	○	●	●	

Sign "○": Lights off, "●": Lights on

- If the valve on the liquid pipe side is not closed, the pump down cannot be performed.
- When LED display changes as shown in the following table, close the 3-way valve on the gas pipe side tightly.

POWER/ MODE	ERROR	PUMP DOWN (L1)	LOW NOISE			PEAK CUT		
			(L2)	(L3)	(L4)	(L5)	(L6)	
●	○	●	○	○	○	○	●	

Sign "○": Lights off, "●": Lights on

- If the valve on the gas pipe side is not closed, refrigerant may flow into the piping after the compressor stops.

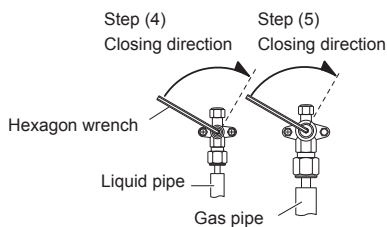

- LED display changes after 1 minute as shown in the table.

POWER/ MODE	ERROR	PUMP DOWN (L1)	LOW NOISE			PEAK CUT		
			(L2)	(L3)	(L4)	(L5)	(L6)	
●	○	●	○	○	○	○	○	

Sign "○": Lights off, "●": Lights on

Fans and compressor stop automatically.

- If the pump down is successfully completed (the above LED display is shown), the outdoor unit remains stopped until the power is turned off.

- Turn the power off.

POWER/ MODE	ERROR	PUMP DOWN (L1)	LOW NOISE			PEAK CUT		
			(L2)	(L3)	(L4)	(L5)	(L6)	
○	○	○	○	○	○	○	○	

Sign "○": Lights off

Pump down is completed.

NOTES:

- To stop pump down, press the [PUMP DOWN] button (S130) again.
- To start the pump down again after the compressor is automatically stopped due to an error, turn the power off and open the 3-way valves. Wait 3 minutes, turn the power on and start the pump down again.
- When starting the operation after completion of the pump down, turn the power off, and then open the 3-way valves. Wait 3 minutes, turn the power on and perform a test run in Cooling operation mode.
- If an error occurs, recover the refrigerant from service port.

10. ERROR CODES

You can determine the operating status by the lighting on and blinking of the LED display.

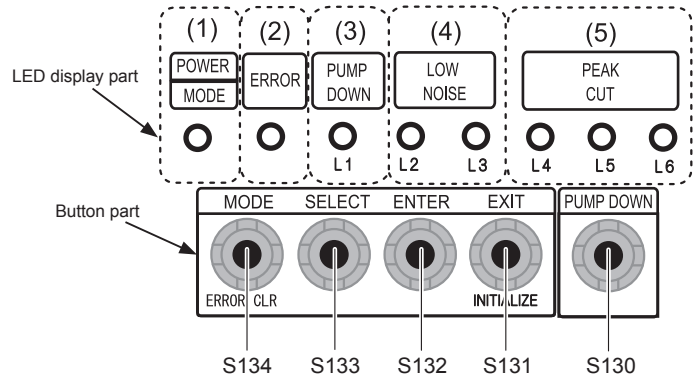

10.1. Error display mode

Display when an error occurs.

POWER/ MODE	ERROR	PUMP DOWN (L1)	LOW NOISE			PEAK CUT		
			(L2)	(L3)	(L4)	(L5)	(L6)	
●	Blink (Hi speed)	○	○	○	○	○	○	

Sign "○": Lights off, "●": Lights on

- Check that the "ERROR" LED blinks, then press the [ENTER] button (S132) once.

10.2. Error code check table

DESCRIPTION	REMARK	LED display							
		POWER/ MODE	ERROR	PUMP DOWN (L1)	LOW NOISE (L2) (L3)		PEAK CUT (L4) (L5) (L6)		
Serial communication error	Serial forward transmission error immediately after operation	Blink (2 times)	●	Blink (1 time)	Blink (1 time)	○	○	●	●
	Serial forward transmission error during operation	Blink (2 times)	●	Blink (1 time)	Blink (1 time)	○	●	○	○
Indoor unit capacity error	Indoor unit capacity error	Blink (2 times)	●	Blink (2 times)	Blink (2 times)	○	○	○	●
Indoor unit error	Indoor unit error	Blink (2 times)	●	Blink (5 times)	Blink (15 times)	○	○	○	●
Outdoor unit main PCB error	Outdoor unit PCB model information error	Blink (2 times)	●	Blink (6 times)	Blink (2 times)	○	○	○	●
Inverter PCB error	Inverter error	Blink (2 times)	●	Blink (6 times)	Blink (3 times)	○	○	○	●
IPM error	Trip terminal L error	Blink (2 times)	●	Blink (6 times)	Blink (5 times)	○	○	●	●
Discharge temp. sensor error	Discharge temp. sensor 1 error	Blink (2 times)	●	Blink (7 times)	Blink (1 time)	○	○	○	●
Compressor temp. sensor error	Compressor temp. sensor 1 error	Blink (2 times)	●	Blink (7 times)	Blink (2 times)	○	○	○	●
Outdoor unit Heat Ex. sensor error	Heat Ex. center temp. sensor error	Blink (2 times)	●	Blink (7 times)	Blink (3 times)	○	○	●	○
	Outdoor unit Heat Ex. liquid temp. sensor error	Blink (2 times)	●	Blink (7 times)	Blink (3 times)	○	○	●	●
Outdoor temp. sensor error	Outdoor temp. sensor error	Blink (2 times)	●	Blink (7 times)	Blink (4 times)	○	○	○	●
Heat sink temp. sensor error	Heat sink temp. sensor error	Blink (2 times)	●	Blink (7 times)	Blink (7 times)	○	○	○	●
Current sensor error	Current sensor 1 error (stoppage permanently)	Blink (2 times)	●	Blink (8 times)	Blink (4 times)	○	○	○	●
Pressure sensor error	High pressure switch 1 error	Blink (2 times)	●	Blink (8 times)	Blink (6 times)	○	●	○	○
	Pressure sensor error	Blink (2 times)	●	Blink (8 times)	Blink (6 times)	○	●	●	○
Trip detection	Trip detection	Blink (2 times)	●	Blink (9 times)	Blink (4 times)	○	○	○	●
Compressor motor control error	Rotor position detection error (stoppage permanently)	Blink (2 times)	●	Blink (9 times)	Blink (5 times)	○	○	○	●
Outdoor unit fan motor 1 error	Duty abnormal	Blink (2 times)	●	Blink (9 times)	Blink (7 times)	○	○	●	●
Outdoor unit fan motor 2 error	Duty abnormal	Blink (2 times)	●	Blink (9 times)	Blink (8 times)	○	○	●	●
4-way valve error	4-way valve error	Blink (2 times)	●	Blink (9 times)	Blink (9 times)	○	○	○	●
Discharge temp. 1 error	Discharge temp. 1 error	Blink (2 times)	●	Blink (10 times)	Blink (1 time)	○	○	○	●
Compressor temp. error	Compressor 1 temp. error	Blink (2 times)	●	Blink (10 times)	Blink (3 times)	○	○	○	●
Pressure error 2	Low pressure error	Blink (2 times)	●	Blink (10 times)	Blink (5 times)	○	○	○	●
IPM error	Temp. error	Blink (2 times)	●	Blink (6 times)	Blink (5 times)	○	○	○	●
Heat sink temp. error	Heat sink temp. error	Blink (2 times)	●	Blink (10 times)	Blink (12 times)	○	○	●	●

Sign "○": Lights off, "●": Lights on