



*Air-cooled liquid chiller for outdoor installation*

# ELFOEnergy Magnum

WSAT-XIN 18.2 - 45.2 RANGE



TECHNICAL BULLETIN



SIZE	18.2	20.2	25.2	30.2	35.2	40.2	45.2
COOLING CAPACITY KW	50,3	63,0	74,6	86,5	99,5	113	125



Clivet is taking part in the EUROVENT certification programme up to 1.500 kW. The products concerned appear in the certified products list of the EUROVENT [www.eurovent-certification.com](http://www.eurovent-certification.com) site.

## ELFOEnergy Magnum, three solutions to satisfy different installation requirements

### MAGNUM COOL ONLY

#### WSAT-XIN:

- Water chiller
- Hot water production by partial energy recovery option



### MAGNUM HEAT PUMP

#### WSAN-XIN:

- Reversible-cycle heat pump



### MAGNUM MULTIFUNCTION

#### WSAN-XIN MF:

- Reversible-cycle heat pump
- Chilled and hot water produced at the same time



## Clivet. Change thing.

**For 25 years, we have been offering solutions to ensure sustainable comfort and the well-being of people and environment.**

Clivet's business strategy has always been clearly defined as the **development of high efficiency systems. It has** placed its R&D department at the complete disposal of this strategy, investing significant financial and human resources in this area and identifying its mission as **"Comfort & Energy Saving"**, at a time when issues such as **energy saving** and **high efficiency** were not yet as central to public opinion as they are today.

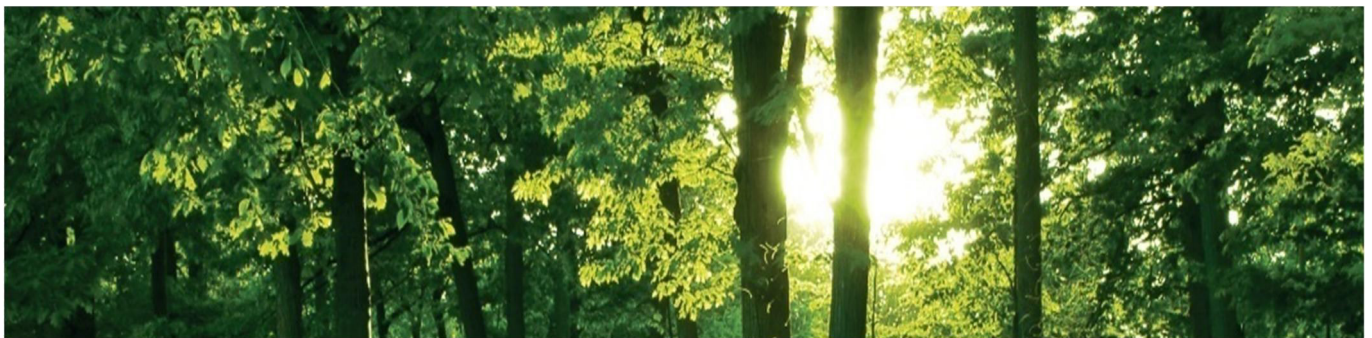

### Medium EE



### Medium XEE



### Magnum XIN

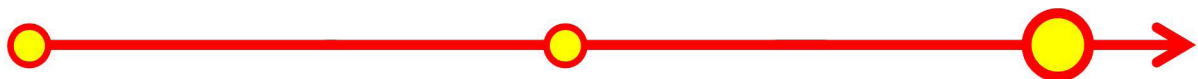

2004

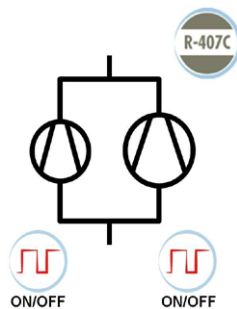

2007

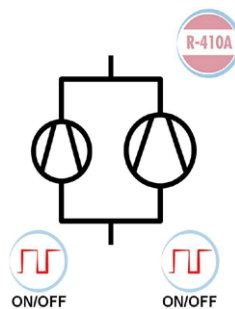

2014

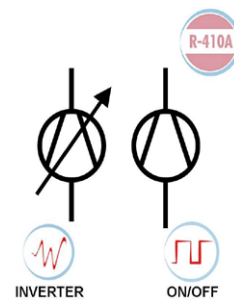

# Maximum efficiency is necessary with a part load

## Load variability

Cooling capacity required from the air conditioning system typically **varies over the year and often even in the course of the same day.**

Climatic conditions vary depending on the place consequently also the load's trend.

The **highest values appear for limited periods of time**, often coinciding with the most demanding weather conditions.

Installation cooling load

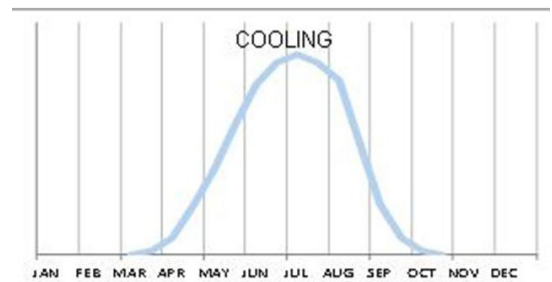

## Maximum efficiency is necessary with a part load

Since the **maximum power** generated by the system is **requested only for short periods of time**, it is fundamental to dispose of the **maximum efficiency in the conditions of part-load.**

This is the only way to actually reduce overall yearly consumptions.

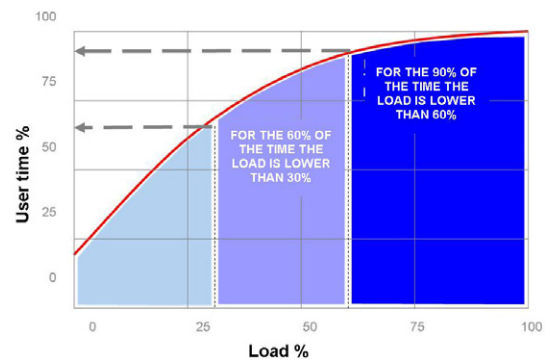

## ELFOEnergy Magnum

The most advanced technologies, enclosed in a single compact unit, combined with the reliability advantages of the **double refrigeration circuit**, guarantee **the best seasonal efficiency.**

- AXITOP fans (optional)
- Ecobreeze fans
- New design optimized for partial loads
- DC Inverter compressor
- VARYFLOW+ Water flow-rate continuous modulation with inverter pumps (optional)
- Electronic thermostatic

## High seasonal efficiency thanks to the capacity continuous modulation

The progressive and sequential activation of the two refrigeration circuits, one controlled by inverter technology, guarantees the complete adjustment to the installation load.

The capacity modulation is necessary starting from minimum values which guarantee the continuous capacity supply depending on the requirements.



## Control of the refrigerant flow

The load variability involves the continuous variation of the refrigerant volume moved by compressors.

The **electronic expansion valve (EEV)**, standard on Clivet units, adapts rapidly and precisely to the actual load required for usage, allowing stable and reliable control in comparison with mechanical thermostatic valves (TEV). This results also in **a further increase in efficiency and longer compressor life**.

The overheating control allows preventing phenomena that are hazardous to the compressors, such as overtemperature and return fluids, thereby increasing even more efficiency and durability.

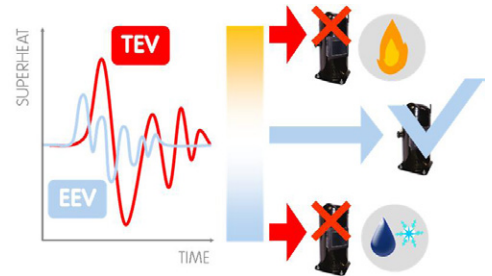

## Efficient heat exchange

The **new plate exchanger design** allows an higher evaporating temperature, guaranteeing a better exchange efficiency, above all in the part-load operating that coincides with the most of the unit operating time.

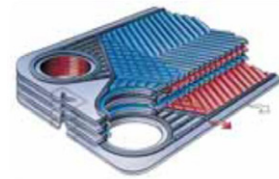

## Standard supplied ECOBREEZE fans, electronically controlled.

With ECOBREEZE, the electric motor with an external rotor is driven by the continuous magnetic switching of the stator, deriving from the integrated electronic control.

User benefits:

- **70% increase in efficiency** thanks to the brushless technology and the special electricity supply;
- **increase in the working life**, thanks to the elimination of the brush wear;
- **reduction in the electrical consumption by the system**, thanks to a drastic reduction of the inrush current for the fans obtained using the integrated 'Soft starter' function.



## Fans at variable speed for minimal noise emission

All units are equipped with **electronic condensation control**. It automatically reduces the fan speed when the heat load is reduced.

Since the fans are the unit's main noise source, the benefits are evident especially during the night hours, when the load is reduced but sensitivity to noise is enhanced.

All this translates into a **reduction of sound pressure down to 8 dB(A)** compared to full load operation in 90% of operating time of the unit.

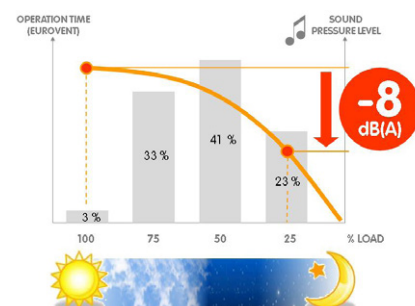

## Efficient and silent ventilation technology (optional)

It is possible to further increase the seasonal efficiency with the innovative air handling system on the external exchangers.

The new AxiTop diffuser creates an ideal air distribution: it aerodynamically decelerates the flow and transforms a big part of its kinetic energy in static pressure.

All AXITOP components are aerodynamically optimized enhancing significantly the efficiency and reducing the impeller speed and consequently the noise.

Obtaining:

- down to -3 dB of silence
- reduction of 3% of the absorbed energy

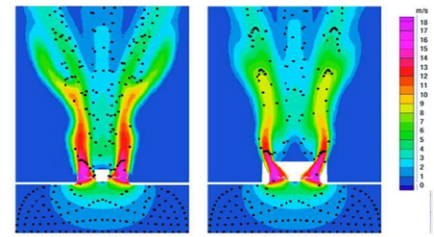

No Axitop                      Axitop



## Water flow-rate continuous modulation (optional)

The energy used for the vector pumping is fundamental on the seasonal efficiency.

The **VARYFLOW+ modulating pumping unit** made up of two pumps in parallel controlled by inverter, allows a precise water flow-rate modulation reducing notably the consumptions and at the same time it guarantees its functionality also in case of temporary unavailability of one of the two pumps, guaranteeing about the 80% of the nominal flow-rate.

**The water flow-rate modulation** can be managed in function of the installation pressure or keeping constant the delta between return and supply temperature.

If the installation water temperature is in critical conditions, **VARYFLOW+** allows to extend the ELFOEnergy Magnum operating ranges guaranteeing the operating.

In case of particular installation needs, the hydronic assemblies are also available:

- **ON/OFF pump:** the traditional solution with high available pressure.
- **ON/OFF pump + ON/OFF pump in stand-by:** the solution that favours reliability. The built-in control balances the operating hours of the two pump and in case of any failure it signals the damage and automatically activates the stand-by pump.

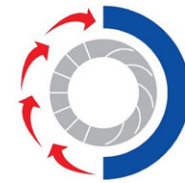

**VARYFLOW+**

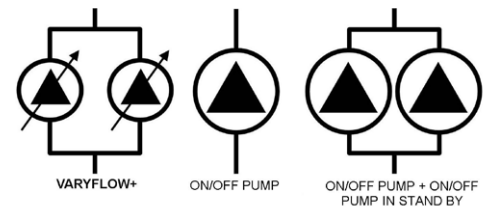

## Integrated inertial storage tank available (optional)

Available only for size 35.2 ÷ 45.2.

In most Magnum systems it can be installed without inertial storage tank on the system. In fact, the unit quickly adapts to the load due to modular compressors, electronic thermostatic valve and low water content plate heat exchangers. However, in the event of hydraulic distribution networks with reduced dimensions, it is important to provide the system with a hydraulic flywheel. In such cases, inertial storage tank is available built-in, equipped with insulating coating and all the necessary safety devices. This allows eliminating installation times and costs and freeing space inside the building.

## Produces hot water freely (optional)

Condensation heat partial recovery:

- it recovers about the 20% of the available heat (desuperheater)

It allows the free DHW production for:

- Hot water coil supply for reheat
- Domestic hot water production (with intermediate exchanger)
- Other processes or operations

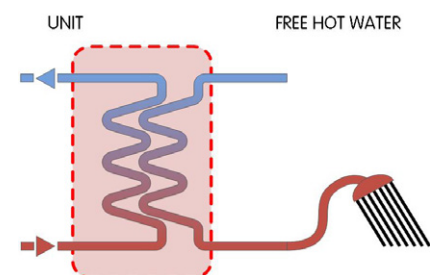

## Advanced control

The control system combines in a single solution the operating efficiency and the user-friendliness.

Continuously monitoring all of the unit operating parameters, it ensures the maintenance of an optimal energy efficiency.

The control includes many safety functions and a complete alarm management.

It also includes advanced functions, such as daily and weekly programming and automatic maximum power consumption limitation (demand limit).

It allows the management of several units in cascade up to 1 master and 6 slave (Ecoshare).

The interface terminal is equipped with a backlit graphic display and a multifunction access keyboard. The multilevel menu is protected by different passwords according to the type of user.



## Remote control (optional)

The remote control allows accessing to the same functions that are accessible by the built-in unit user interface, and can be installed at a maximum distance of 350 meters.



## Even for low water temperature

The unit is also perfectly adapted for use in process cooling where the low temperature version (Brine) together with the addition of glycol to the thermo-vector liquid produces chilled water down to  $-8^{\circ}\text{C}$ .



## Remote system management:

Magnum is standard equipped with:

- potential-free contact for remote on/off control
- potential-free contacts for remote display of the compressor status
- setting from user interface: Off / local On / serial On
- potential-free contact to remote any possible alarm

The various communication protocols allow the unit to exchange information with the main supervision systems by means of serial connections.



## Controlled power supply

Proper power supply ensures optimal unit operation and protects its many electrical components.

The phase monitor, standard supplied:

- controls the presence and the exact sequence of the phases
- checks any voltage anomalies (-10%)
- automatically restarts the unit as soon as the proper power supply is restored.

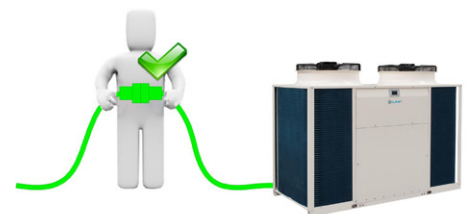



## Modularity

In the event of particularly large buildings requiring high capacities, it is advisable to use several units.

The Magnum units are designed to be connected in parallel in modular logic, thereby granting the following advantages:

Increased flexibility, enhanced by the control that can adapt to the load;

Increased reliability, since the malfunction of one unit does not compromise the capacity supply of the other units;

Increased efficiency, since energy is produced where and when required, according to the area served.

The microprocessor control combined with ECOSHARE allows controlling up to 7 units in local network (1 Master unit and 6 Slave).

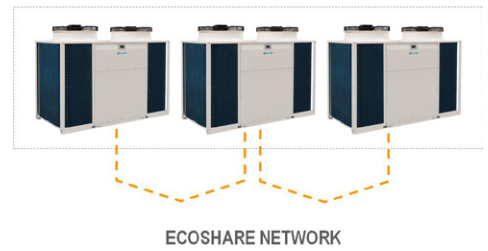

## Compact unit

All these distinctive elements are included in only one packaged solution.

The new design reduces the overall dimensions and allows a simplified access, both front and rear, allowing a quick maintenance.



# ELFOEnergy Magnum

## System solutions:

### Standard unit

- Production of chilled water

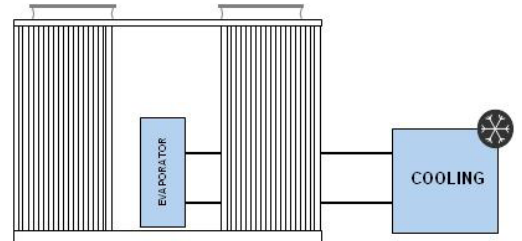
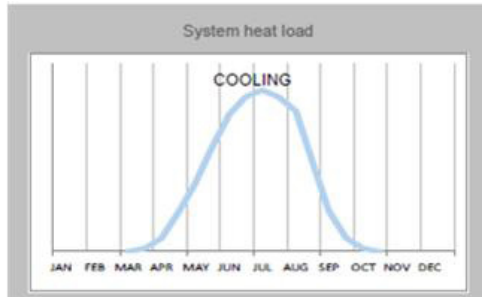

### Unit with Partial energy recovery option

- Production of chilled water
- Free production of hot water from partial energy recovery

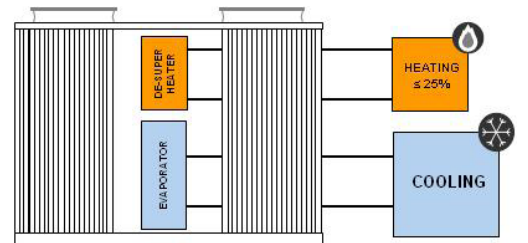
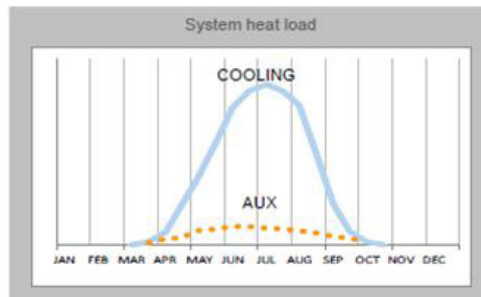

# Unit configuration

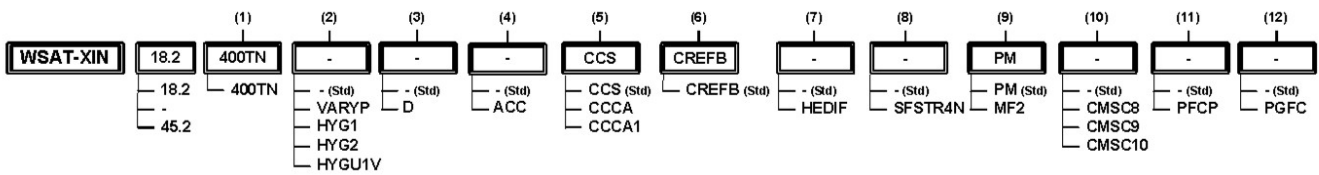

### (1) Voltage

Supply voltage 400/3/50+N (standard)

### (2) User side hydronic unit

Refer to the diagrams of the hydronic assembly reported

### (3) Partial recovery device

(-) not required (standard)

D - Partial energy recovery

### (4) Storage tank

(-) not required (standard)

ACC - Storage tank (only for size 35.2 ÷ 45.2)

### (5) Condensing coil

CCS - Standard condenser coil (standard)

CCA - Copper / aluminium condenser coil with acrylic lining

CCA1 - Condenser coil with Energy Guard DCC Aluminum

### (6) Type of fans

CREFB - ECOBREEZE external section fans consumption reduction device (Standard)

### (7) Diffuser for fan

(-) not required (standard)

HEDIF - Diffuser for high efficiency axial fan

### (8) Soft starter

(-) not required (standard)

SFSTR4N - Disposal for inrush current reduction, for unit 400/3/50+N

### (9) Phase monitor

PM - Phase monitor (standard)

MF2 - Multi-function phase monitor

### (10) Serial communication module

(-) not required (standard)

CMSC8 - Serial communication module to BACnet supervisor

CMSC9 - Serial communication module to Modbus supervisor

CMSC10 - Serial communication module to LonWorks supervisor

### (11) Power capacitors

(-) not required (standard)

PFCC - Power factor correction capacitors (cosφ > 0.95)

### (12) Protection grill

(-) not required (standard)

PGFC - Finned coil protection grill

Functionalities	Hydronic units				
<b>2 PIPE SYSTEM</b>  Chilled water production for installation	<b>1.1</b> Standard unit (Std)	<b>1.2</b> Unit with VARYFLOW+ (VARYP)	<b>1.3</b> Unit with one ON/OFF pump (HYG1)	<b>1.4</b> Unit with two ON/OFF pumps (HYG2)	<b>1.5</b> Unit with one INVERTER pump (HYGU1V)
<b>2 PIPE SYSTEM + PARTIAL REGENERATION</b>  Chilled water production for installation - Hot water production with partial recovery	<b>2.1</b> Unit with partial recovery (D)	<b>2.2</b> Unit with partial recovery and VARYFLOW+ (D+VARYP)	<b>2.3</b> Unit with partial recovery and one ON/OFF pump (D+HYG1)	<b>2.4</b> Unit with partial recovery and two ON/OFF pumps (D+HYG2)	<b>2.5</b> Unit with partial recovery and one INVERTER pump (D+HYGU1V)

### Accessories separately supplied

<ul style="list-style-type: none"> <li>• <b>RCTX</b> - Remote control</li> </ul>	<ul style="list-style-type: none"> <li>• <b>BACX</b> - BACnet serial communication module</li> <li>• <b>CMMBX</b> - Serial communication module to supervisor (Modbus)</li> <li>• <b>CMSLWX</b> - LonWorks serial communication module</li> </ul>	<ul style="list-style-type: none"> <li>• <b>PGFCX</b> - Finned coil protection grill</li> <li>• <b>IFWX</b> - Steel mesh strainer on water side</li> </ul>	<ul style="list-style-type: none"> <li>• <b>AVIBX</b> - Anti-vibration mount support</li> </ul>
--	---	--	---

## General technical data

Size			18.2	20.2	25.2	30.2	35.2	40.2	45.2
<b>Cooling</b>									
Cooling capacity	1	kW	50,3	63,0	74,6	86,5	99,5	113	125
Compressor power input	1	kW	13,5	17,8	20,6	24,4	28,0	32,6	36,4
Total power input	2	kW	14,6	18,9	22,0	25,8	29,6	34,3	38,1
EER	1		3,44	3,33	3,39	3,35	3,36	3,29	3,28
Water flow-rate	1	l/s	2,40	3,01	3,56	4,13	4,75	5,38	5,96
User side exchanger pressure drops	1	kPa	20	30	23	22	28	25	30
Cooling capacity (EN14511:2013)	3	kW	50,1	62,7	74,3	86,3	99,1	112	124
Total power input (EN14511:2013)	3	kW	16,1	20,2	23,9	27,6	31,8	36,1	40,1
EER (EN14511:2013)	3		3,12	3,10	3,11	3,13	3,12	3,11	3,10
SEER	6		3,80	3,86	3,80	4,09	4,02	4,07	4,36
Minimum cooling capacity	3	kW	14,5	14,5	14,5	20	20	20	29
<b>Compressor</b>									
Type of compressors			SCROLL INVERTER + SCROLL ON/OFF						
Refrigerant			R-410A						
No. of compressors		No	2	2	2	2	2	2	2
Oil charge (C1)		l	3,0	3,3	3,3	3,6	3,6	6,7	6,7
Oil charge (C2)		l	3,3	3,3	3,3	3,6	3,6	3,6	6,7
Refrigerant charge (C1)		Kg	6,0	5,5	7,0	8,5	11,0	12,0	13,0
Refrigerant charge (C2)		Kg	6,0	5,5	7,0	8,5	11,0	11,5	15,5
Refrigeration circuits		No	2	2	2	2	2	2	2
<b>User side exchanger</b>									
Type of exchanger	4		PHE						
No. of exchangers		No	1	1	1	1	1	1	1
Water content		l	9,9	9,9	14,7	14,7	15,7	17,4	18,0
<b>External Section Fans</b>									
Type of fans	5		EC						
No. of fans		No	2	2	2	2	2	2	2
Standard airflow		l/s	10556	10556	13056	13056	13333	14167	14167
Installed unit power		kW	1,1	1,1	1,4	1,4	1,4	1,7	1,7
<b>Connections</b>									
Water fittings			2"	2"	2"1/2	2"1/2	2"1/2	2"1/2	2"1/2
<b>Water circuit</b>									
Maximum water side pressure		kPa	1000	1000	1000	1000	1000	1000	1000
Min. installation water contents		l	60	91	102	117	121	157	159
<b>Power supply</b>									
Standard power supply		V	400/3/50+N	400/3/50+N	400/3/50+N	400/3/50+N	400/3/50+N	400/3/50+N	400/3/50+N

The Product is compliant with the Erp (Energy Related Products) European Directive. It includes the Commission delegated Regulation (EU) No 2016/2281, also known as Ecodesign Lot21. 'Contains fluorinated greenhouse gases' (GWP 2087,5)

1. Data referred to the following conditions: Internal exchanger water temperature = 12/7°C Entering external exchanger air temperature = 35°C
2. The Total Power Input value does not take into account the part related to the pumps and required to overcome the pressure drops for the circulation of the solution inside the exchangers
3. Data compliant to Standard EN 14511:2013 referred to the following conditions: - Internal exchanger water temperature = 12/7°C - Entering external exchanger air temperature = 35°C
4. PHE = plate exchanger
5. AX = axial fan
6. Data calculated according to the EN 14825:2016 Regulation

## Electrical data

### Supply voltage 400/3/50+N

Size			18.2	20.2	25.2	30.2	35.2	40.2	45.2
<b>F.L.A. - Full load current at max admissible conditions</b>									
F.L.A. - Compressor 1 (ON/OFF)		A	16,8	24,3	26,6	30,8	30,8	40,6	40,6
F.L.A. - Compressor 2 (INVERTER)		A	20,8	20,8	23,3	29,5	32,1	32,1	40,5
F.L.A. - Single External Fan		A	3,9	3,9	3,9	3,9	3,9	3,9	3,9
F.L.A. - Total		A	45,5	52,9	57,7	68,1	70,7	80,5	88,9
<b>L.R.A. - Locked rotor amperes</b>									
L.R.A. - Compressor 1 (ON/OFF)		A	98,0	147	158	197	197	215	215
L.R.A. - Compressor 2 (INVERTER)		A	20,8	20,8	23,3	29,5	32,1	32,1	40,5
<b>F.L.I. - Full load power input at max admissible conditions</b>									
F.L.I. - Compressor 1 (ON/OFF)		kW	9,7	14,6	16,5	18,5	18,5	24,8	24,8
F.L.I. - Compressor 2 (INVERTER)		kW	12,7	12,7	14,6	18,0	19,6	19,6	26,7
F.L.I. - Single External Fan		kW	2,56	2,56	2,56	2,56	2,56	2,56	2,56
F.L.I. - Total		kW	27,5	32,5	36,3	41,6	43,3	49,6	56,6
<b>M.I.C. - Maximum unit starting current</b>									
M.I.C - Value		A	126,6	175,6	189,1	234,3	237,0	255,0	263,3
M.I.C - With soft start accessory		A	77,6	102,1	110,1	135,8	138,4	147,4	155,8

Power supply: 400/3/50 Hz. Voltage variation: max. +/-10%

Voltage unbalance between phases: max 2 %

For non standard voltage please contact Clivet technical office

Units are in compliance with the european law CEI EN 60204 and CEI EN 60335.

## Sound levels

### Standard unit

Size	Sound power level (dB)								Sound pressure level	Sound power level
	Octave band (Hz)									
	63	125	250	500	1000	2000	4000	8000	dB(A)	dB(A)
18.2	90	83	78	80	78	72	67	61	65	82
20.2	89	82	80	81	77	72	64	59	65	82
25.2	90	83	80	81	79	74	68	60	66	83
30.2	91	84	82	83	78	75	66	59	66	84
35.2	91	85	82	84	79	74	67	61	68	85
40.2	92	85	83	84	80	75	67	62	68	85
45.2	94	85	83	84	82	77	71	63	69	86

Sound levels refer to units with full load under nominal test conditions.

The sound pressure level refers to a distance of 1 meter from the outer surface of the unit operating in open field.

Noise levels are determined using the tensiometric method (UNI EN ISO 9614-2)

Data referred to the following conditions:

internal exchanger water = 12/7°C

ambient temperature = 35 °C

### Unit with HEDIF - "Diffuser for high efficiency axial fan" option

Size	Sound pressure level	Sound power level
	dB(A)	dB(A)
18.2	63	80
20.2	63	80
25.2	64	81
30.2	64	82
35.2	66	83
40.2	66	83
45.2	67	84

Sound levels refer to units with full load under nominal test conditions.

The sound pressure level refers to a distance of 1m from the outer surface of the unit operating in an open field.

Noise levels are determined using the tensiometric method (UNI EN ISO 9614-2)

Data referred to the following conditions:

internal exchanger water = 12/7°C

ambient temperature = 35 °C

# Operating range

## Cooling

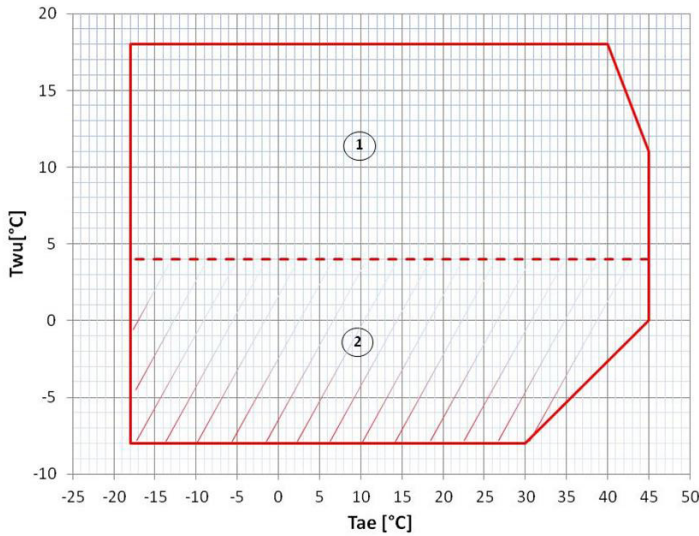

$T_{wu}$  [°C] = Internal exchanger outlet water temperature  
 $T_{ae}$  [°C] = External exchanger inlet air temperature

1. Standard unit operating range at full load
2. Operating range where the use of ethylene glycol is mandatory in relation to the temperature of the water at the outlet of the user side exchanger

## Unit equipment with low outdoor temperatures

Minimum outdoor air temperature	Operating unit	Unit in stand-by* (fed unit)	Unit in storage (unit not fed)
-11°C	√ standard unit	√ standard unit	√ standard unit (2)
+2°C			
-7°C			
-10°C			
Between -10°C and -15°C	√ glycol in an appropriate percentage (1)	√ glycol in an appropriate percentage (1)	NOT POSSIBLE
Between -15°C and -18°C	√ glycol in an appropriate percentage (1) X not compatible with Clivet integrated pumping device	√ glycol in an appropriate percentage (1) X not compatible with Clivet integrated pumping device	

Data referred to the following conditions:  
 internal exchanger water = 12/7°C

\* consider the unit powered electrically, with active control on pumping units. It is recommended to set a set-point value lower than standard (eco mode)

1. Operating range where the water pumping unit must be powered and always active, or with a periodical activation of the outdoor temperature operating pump to guarantee the correct unit operation.
2. Unit without water or containing water with an appropriate quantity of glycol.

At the unit start-up the water temperature or water with glycol must be inside the operating range indicated in the "Operating range" graph.  
 To know the water freezing temperature at the glycol percentage changing refer to the specific 'Correction factor for antifreeze solutions' table.



Air conditions which are at rest are defined as the absence of air flowing towards the unit. Weak winds can induce air to flow through the exchanger and air-levels which can cause a reduction in the operating range. In the presence of predominant winds it is necessary to use suitable windbreak barriers.

## Correction factors for glycol use

### Internal exchanger (evaporator)

% ethylene glycol by weight			5%	10%	15%	20%	25%	30%	35%	40%
Freezing temperature		°C	-2,0	-3,9	-6,5	-8,9	-11,8	-15,6	-19,0	-23,4
Safety temperature		°C	3	1	-1	-4	-6	-10	-14	-19
Cooling Capacity Factor			0,995	0,990	0,985	0,981	0,977	0,974	0,971	0,968
Compressor power input Factor			0,997	0,993	0,990	0,988	0,986	0,984	0,982	0,981
Internal exchanger glycol solution flow factor			1,003	1,010	1,020	1,033	1,050	1,072	1,095	1,124
Pressure drop Factor			1,029	1,060	1,090	1,118	1,149	1,182	1,211	1,243

## Fouling Correction Factors

m <sup>2</sup> °C/W	Internal exchanger	
	F1	FK1
0,44 x 10 <sup>-4</sup>	1,0	1,0
0,88 x 10 <sup>-4</sup>	0,97	0,99
1,76 x 10 <sup>-4</sup>	0,94	0,98

F1 = Cooling capacity correction factors

FK1 = Compressor power input correction factor

## Overload and control device calibrations

			Open	Closed	Value
High pressure safety pressure switch		kPa	4050	3300	-
Low pressure switch		kPa	450	600	-
Low pressure switch (Brine)		bar	200	350	-
Antifreeze protection		°C	3	5,5	-
high pressure safety valve		kPa	-	-	4500
Low pressure safety valve		kPa	-	-	3000
Max no. of compressor starts per hour		No	-	-	10
High compressor discharge temperature safety thermostat		°C	-	-	120

# Standard unit technical specifications

## Compressor

First circuit: Hermetic scroll compressor, complete with motor over-temperature and over-current devices and protection against excessive gas discharge temperature. Fitted on rubber antivibration mounts and complete with oil charge. The automatic oil heater prevents the oil from being diluted by the refrigerant when the compressor stops.

Second circuit: Hermetic orbiting scroll compressor, complete with motor over-temperature and over-current devices and protection against excessive gas discharge temperature. Fitted on rubber antivibration mounts and complete with oil charge. The automatic oil heater prevents the oil from being diluted by the refrigerant when the compressor stops.

## Structure

Supporting structure realised with steel frame with zinc-magnesium superficial treatment painted with polyester powder RAL 9001, that ensures excellent mechanical features and high long-term resilience against corrosion.

## Panelling

External sheet steel panelling with pre-painted zinc-magnesium superficial treatment that ensures superior resistance to corrosion for outdoor installation and eliminates the need for periodical painting. The panels can be easily removed to fully access internal components and are lined with sound-proof material on the inside to contain the unit's sound levels.

## Internal exchanger

Direct expansion heat exchanger, braze-welded AISI 316 stainless steel plates with large exchange surface and complete with external heat and anti-condensate insulation.

The exchanger is complete with:

- differential pressure switch, water side
- antifreeze heater to protect the water side exchanger, preventing the formation of frost if the water temperature falls below a set value.

## External exchanger

Direct expansion finned coil exchanger made with copper pipes placed on staggered rows mechanically expanded to better adhere to the fin collar. The fins are made from aluminium with a corrugated surface and adequately distanced to ensure the maximum heat exchange efficiency.

## Fan

Axial fans with sickle-shaped blades with "Winglets" at the end, coupled directly to a three phase electric external rotor motor with heat protection incorporated, with IP 54 operation. Housed in aerodynamically shaped nozzles to increase efficiency and minimize noise levels. They are fitted with protective safety guard grilles. Supplied with variable speed control (ECOBREEZE).

## Refrigeration circuit

Double refrigeration circuit complete, for each circuit, with:

- replaceable anti-acid solid cartridge dehydrator filter
- high pressure safety pressure switch
- high pressure transducer
- low pressure transducer
- refrigerant temperature probe
- electronic thermostatic expansion valve
- high pressure safety valve



## Electrical panel

The capacity section includes:

- main door lock isolator switch
- isolating transformer for auxiliary circuit power supply
- on-off scroll compressor protection magnetothermic
- inverter scroll compressor protection fuses
- Inverter, complete with thermal protection, for continuous control of the modulating scroll compressor revolutions
- fan protection fuses and heat protection
- on-off scroll compressor control contactor

The control section includes:

- interface terminal with graphic display
- display of the set values, the error codes and the parameter index
- ON/OFF and alarm reset buttons
- proportional-integral water temperature control
- daily, weekly programmer of temperature set-point and unit on/off
- Set point compensation in function of the outdoor air temperature
- set-point compensation with 0-10 V signal
- unit switching on management by local or remote (serial)
- antifreeze protection water side
- compressor overload protection and timer
- prealarm function for water antifreeze and high refrigerant gas pressure
- self-diagnosis system with immediate display of the fault code
- automatic rotation control for compressor starts
- compressor operating hour display
- input for remote ON/OFF control
- relay for remote cumulative fault signal
- inlet for demand limit (power input limitation according to a 0÷10V external signal)
- digital input for double set-point enabling
- potential-free contacts for compressor status
- phase monitor
- ECOSHARE function for the automatic management of a group of units
- numeration of electrical panel cables

## Electronic control

### Description of step start-up control

The electronic control allows to manage the unit depending on the requested load.

The compressor step activation favours the maximum efficiency and manages at its best the inverter compressor.

The inverter compressor is activated first modulating the capacity in function of the installation return temperature and controlling the supply temperature with PID control.



### Main controls

Leaving water temperature control with PID algorithm: it keeps the leaving mean temperature to a set value.

- Auto-adaptive switching on differential: guarantees the compressors minimum operating time in systems with low water content.
- Set point compensation with outdoor temperature
- Condensation control based on pressure
- Pre-alarms at automatic reset: in case of alarm it is allowed a certain number of restarts before the definitive lock.
- Compressor operating hour calculation
- Compressor start calculation
- Control and continuous management of the compressor operating conditions to guarantee the unit operating also in extreme conditions
- Water temperature check (when used) to avoid the pipe freezing
- "Anti-snow" function: in case of heavy snowfalls, it avoid the deposit of snow on fans
- Alarm log
- Autostart after voltage drop
- Local or remote control

### Unit status display

By the user interface is possible to display:

- unit operating status
- Leaving/entering water temperature
- Outdoor air temperature
- Refrigeration circuit pressure and temperatures (circuit 1 and 2)
- Signalling of alarms and anomalies in progress.

### Probe, transducer and parameter display

A user interface dedicated section allows the maintenance or technical assistance personnel to control the unit operating stata.

This section is accessible only by specialized personnel.

### Management of more units in cascade (ECOSHARE)

It allows the management of several units hydraulically connected up to 1 master and 6 slave maximum.

Units must be of the same type: all reversible heat pumps, or all cool only, or all heat only. Sizes can be different.

The communication among the units is via a BUS serial cable allowing:

- Supply water set-point setting of the slave units
- Setting of logics that increase the system energy efficiency
- Unit operating hours balancing
- Unit management in case of damage (only on slave unit)
- Hydronic assembly switch-off management of units not used

### RCTX - Remote control

The remote control allows the full control of all unit functions from remote position.

It can be easily installed on the wall and has the same aspect and functions of the user interface on the unit.

# Hydronic assembly configuration - 1.1

## Standard unit

Configuration without hydronic assembly, equipped with components as described on the water diagram key.  
All water fittings are Victaulic type. It is possible to control an external pump by an on/off or 0-10V signal.

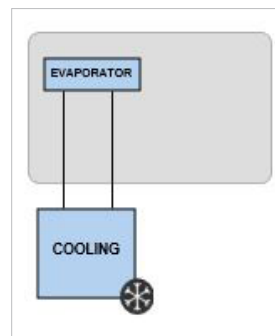

## Internal exchanger pressure drop curves

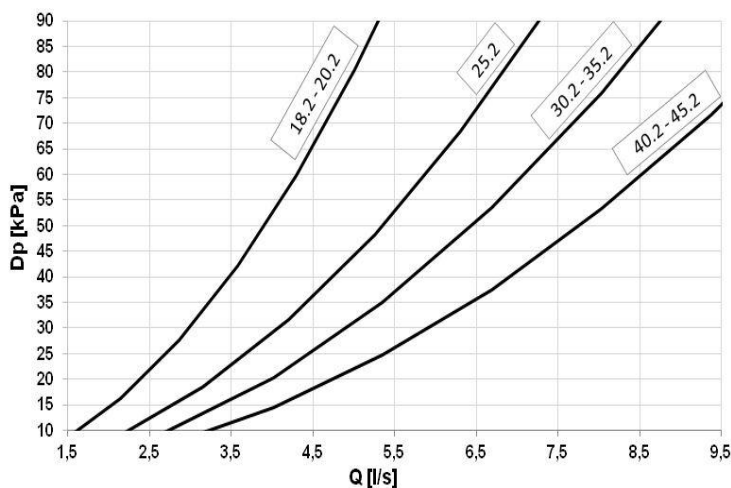

The pressure drops on the water side are calculated by considering an average water temperature at 7°C.

Q = Water flow rate [l/s]  
DP = Pressure drops [kPa]

The water flow rate must be calculated with the following formula

$$Q \text{ [l/s]} = kWf / (4,186 \times DT)$$

kWf = Cooling capacity [kW]  
DT = Temperature difference between entering / leaving water

To the internal exchanger pressure drops must be added the pressure drops of the steel mesh mechanical strainer that must be placed on the water input line. It is a device compulsory for the correct unit operation, and it is available as Clivet option (IFWX).

## Admissible water flow rates

Minimum (Qmin) and maximum (Qmax) water flow-rates admissibles for the correct unit operation.

Size		18.1	20.2	25.2	30.2	35.2	40.2	45.2
Qmin	[l/s]	1,7	1,7	2,3	2,7	2,7	3,3	3,3
Qmax	[l/s]	5,6	5,6	7,7	9,3	9,3	11,1	11,1

## Water diagram

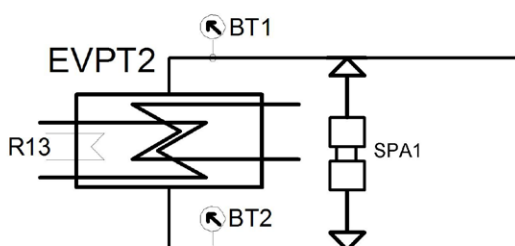

EVPT2 = Plate evaporator 2 circuits  
R13 = Evaporator group heater  
BT1 = Probes of entering water temperature  
BT2 = Probes of leaving water temperature  
SPA1 = Differential water pressure switch

## Hydronic assembly configuration - 1.2

### Unit with VARYFLOW+ (VARYP)

Configuration with 2 centrifugal electric pumps arranged in parallel and controlled by inverter, with housing and impeller made with AISI 304 stainless steel, and components as described on the water diagram key. All water fittings are Victaulic type.

The electric pumps are equipped with three-phase electric motor with IP55-protection and complete with thermoformed insulated casing.

The control, modulates the water flow-rate keeping constant the delta T. If the water temperature is in critical conditions, it allows to extend the unit operating ranges guaranteeing its operating, automatically reducing the water flow-rate. In the event of one of the two pumps is temporarily unavailable, it guarantees about the 80% of the nominal flow-rate.

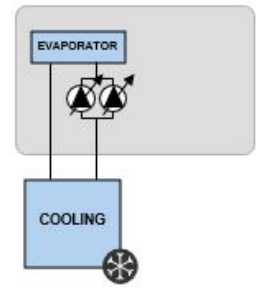

#### VARYFLOW+ pressure head (Size 18.2 - 30.2)

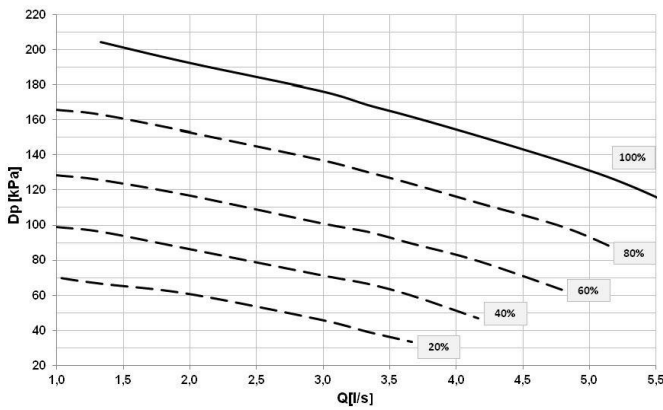

Q = Water flow rate [l/s] DP = Pressure drop [kPa]

#### VARYFLOW+ pressure head (Size 35.2 - 45.2)

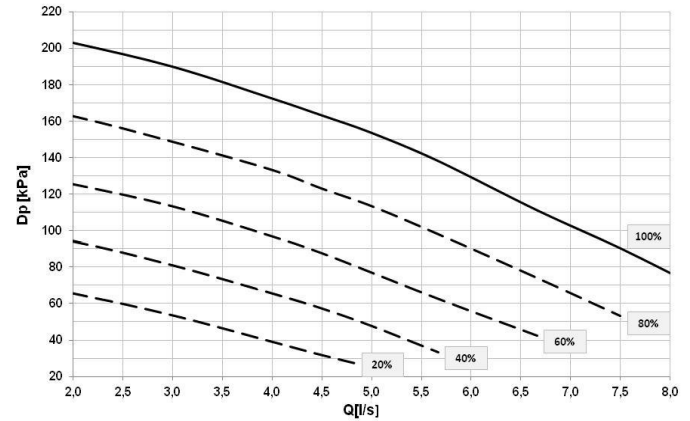

Caution: to obtain the available pressure values, you need to subtract the following from the head values represented in these diagrams:

- User side exchanger pressure drops
- IFVX accessory –Steel mesh filter on the water side (where applicable)

#### VARYFLOW+ absorption curves (Size 18.2 - 30.2)

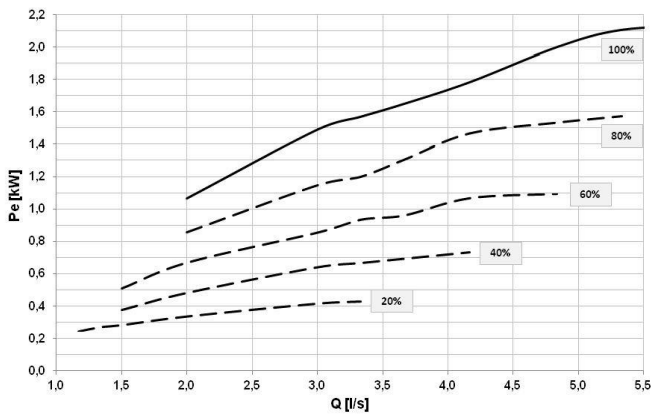

Q = Water flow rate [l/s] Pe = Electric power consumption [kW]

#### VARYFLOW+ absorption curves (Size 35.2 - 45.2)

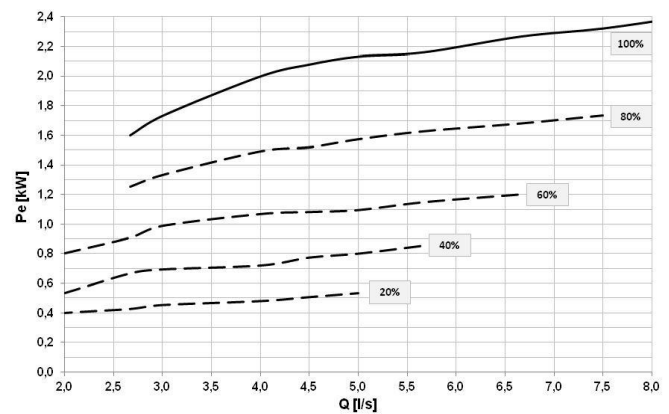

### Water diagram

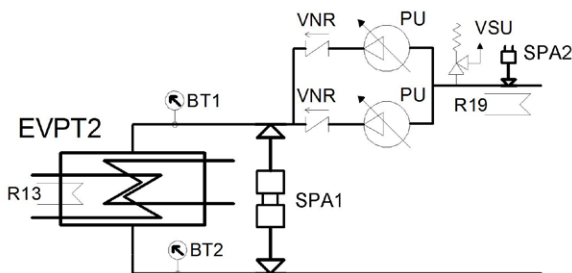

- EVPT2 = Plate evaporator 2 circuits
- R13 = Evaporator group heater
- BT1 = Probes of entering water temperature
- BT2 = Probes of leaving water temperature
- VNR = Non return valves
- SPA1 = Differential water pressure switch
- PU = Hydronic assembly VARYFLOW +
- VSU = Water safety valve
- R19 = Hydronic assembly heaters
- SPA2 = System water pressure switch

## Hydronic assembly configuration - 1.3

### Unit with one ON/OFF pump (HYG1)

Configuration with 1 centrifugal electric pump, with housing and impeller made with AISI 304 stainless steel, and components as described on the water diagram key. All water fittings are Victaulic type.

The electric pump is equipped with three-phase electric motor with IP55-protection and complete with thermoformed insulated casing.

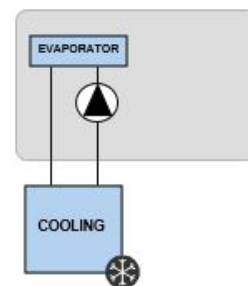

#### ON/OFF pump pressure head (Size 18.2 - 45.2)

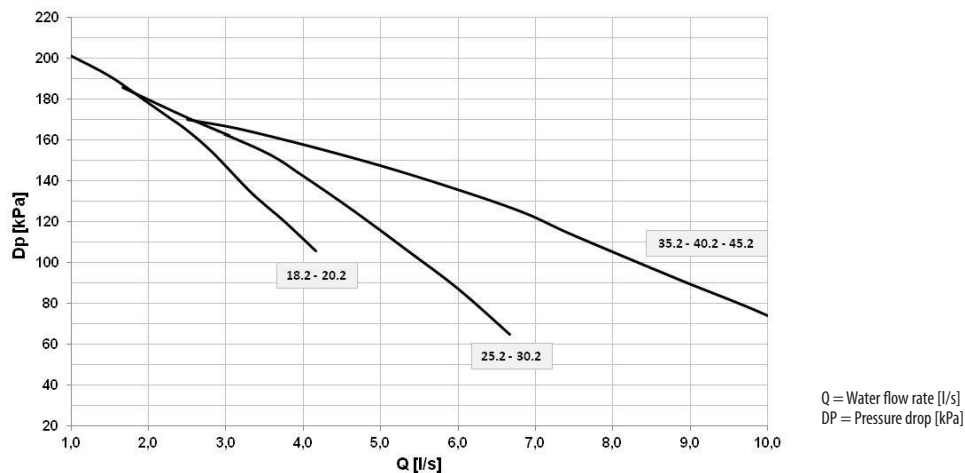

Q = Water flow rate [l/s]  
DP = Pressure drop [kPa]

Caution: to obtain the available pressure values, you need to subtract the following from the head values represented in these diagrams:



- User side exchanger pressure drops
- IFVX accessory –Steel mesh filter on the water side (where applicable)

#### ON/OFF pump absorption curves (Size 18.2 - 45.2)

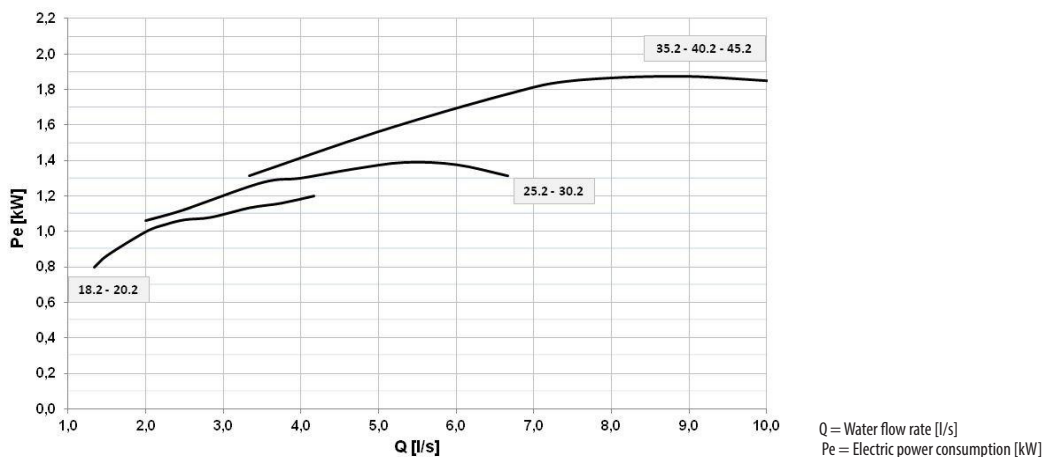

Q = Water flow rate [l/s]  
Pe = Electric power consumption [kW]

### Water diagram

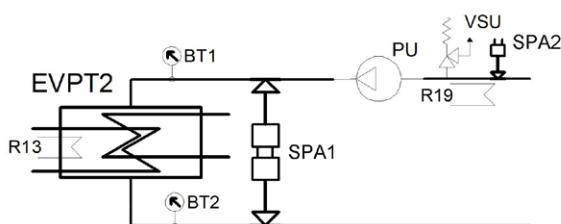

- EVPT2 = Plate evaporator 2 circuits
- R13 = Evaporator group heater
- BT1 = Probes of entering water temperature
- BT2 = Probes of leaving water temperature
- SPA1 = Differential water pressure switch
- PU = Hydronic assembly 1 ON/OFF pump
- VSU = Water safety valve
- R19 = Hydronic assembly heaters
- SPA2 = System water pressure switch

## Hydronic assembly configuration - 1.4

### Unit with two ON/OFF pumps (HYG2)

Configuration with 2 centrifugal electric pumps, 1 stand-by, with housing and impeller made with AISI 304 stainless steel, and components as described on the water diagram key. All water fittings are Victaulic type.

The electric pumps are equipped with three-phase electric motor with IP55-protection and complete with thermoformed insulated casing.

The control balances the operating hours and in case of failure it is signaled and the stand-by pump is automatically activated.

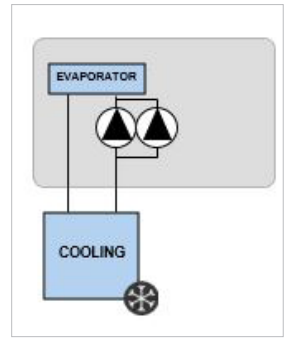

#### ON/OFF pump pressure head (Size 18.2 - 45.2)

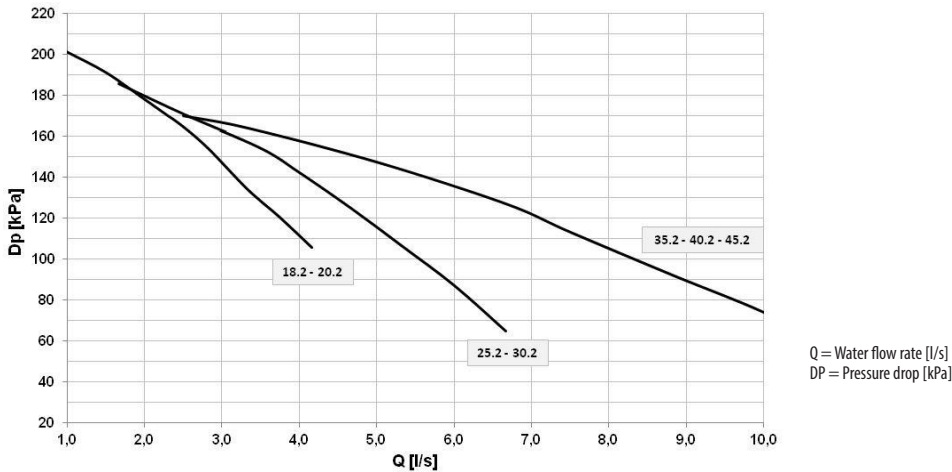

Caution: to obtain the available pressure values, you need to subtract the following from the head values represented in these diagrams:

- User side exchanger pressure drops
- IFVX accessory –Steel mesh filter on the water side (where applicable)

#### ON/OFF pump absorption curves (Size 18.2 - 45.2)

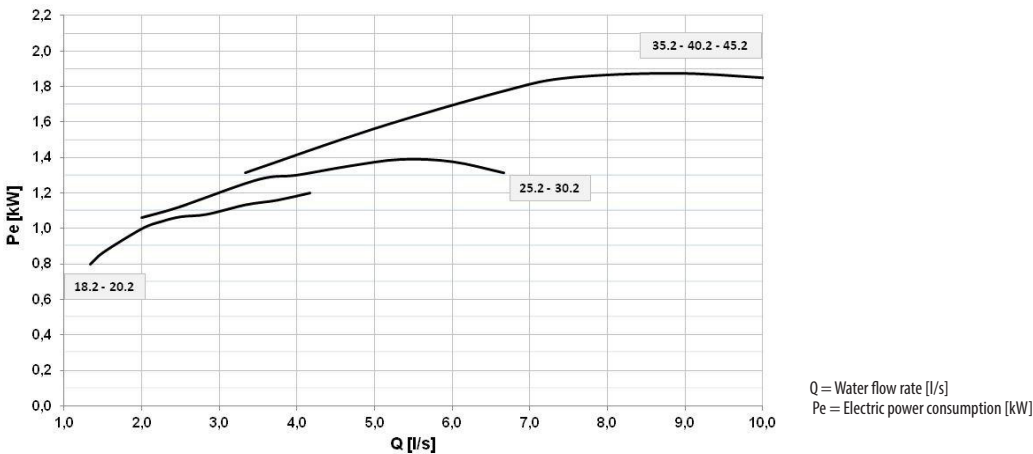

### Water diagram

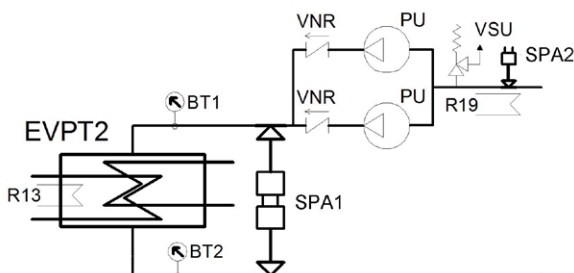

- EVPT2 = Plate evaporator 2 circuits
- R13 = Evaporator group heater
- BT1 = Probes of entering water temperature
- BT2 = Probes of leaving water temperature
- SPA1 = Differential water pressure switch
- PU = Hydronic assembly 2 ON/OFF pumps
- VSU = Water safety valve
- R19 = Hydronic assembly heaters
- SPA2 = System water pressure switch

# Hydronic assembly configuration - 1.5

## Unit with one INVERTER pump (HYGU1V)

This configuration provides for one inverter-controlled electric centrifugal pump with body and impeller in AISI 304 steel and components listed in the key of the included water diagram. All water fittings are Victaulic. The electric pump is equipped with three-phase electric motor with IP55-protection and complete with thermoformed insulated casing.

Adjustment enables the optimised load distribution according to the system requirements.

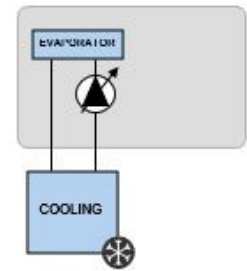

### Inverter pump pressure head (Size 18.2 - 20.2)

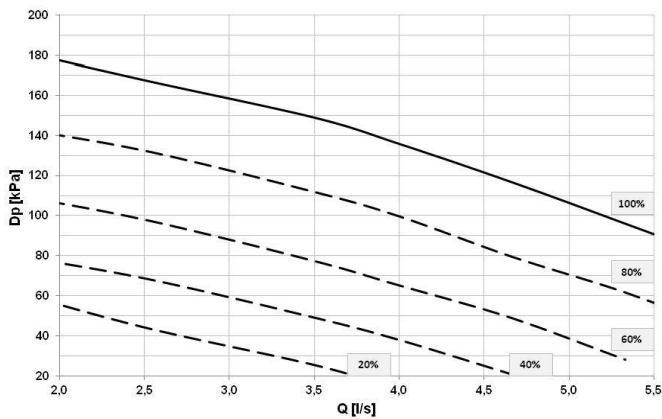

Q = Water flow rate [l/s]  
DP = Pressure head [kPa]

### Inverter pump pressure head (Size 25.2 - 30.2)

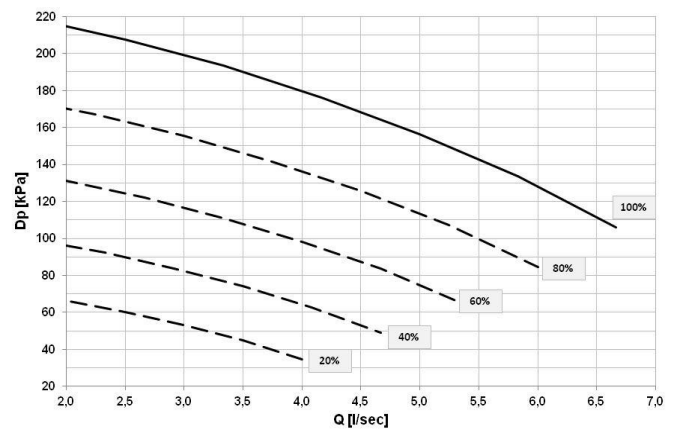

Q = Water flow rate [l/s]  
DP = Pressure head [kPa]

### Inverter pump absorption curve (Size 18.2 - 20.2)

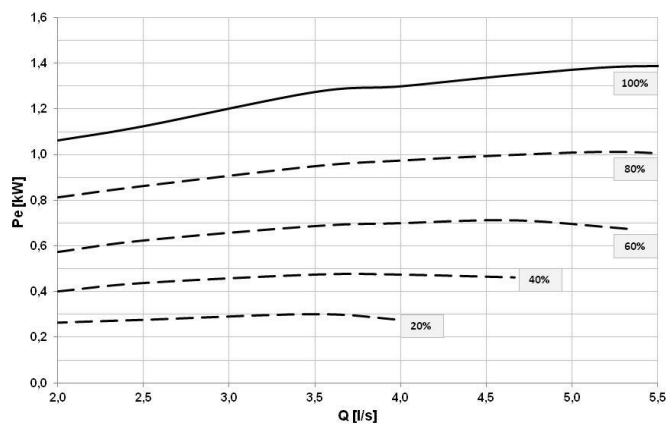

Q = Water flow rate [l/s]  
Pe = Electric power consumption [kW]

### Inverter pump absorption curve (Size 25.2 - 30.2)

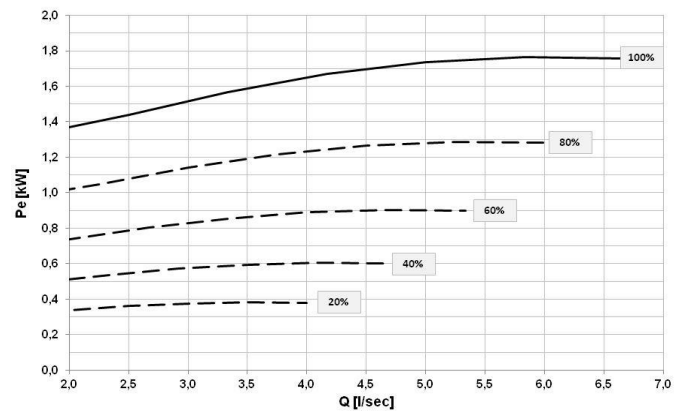

Q = Water flow rate [l/s]  
Pe = Electric power consumption [kW]

### Inverter pump available pressure (Size 35.2 - 45.2)

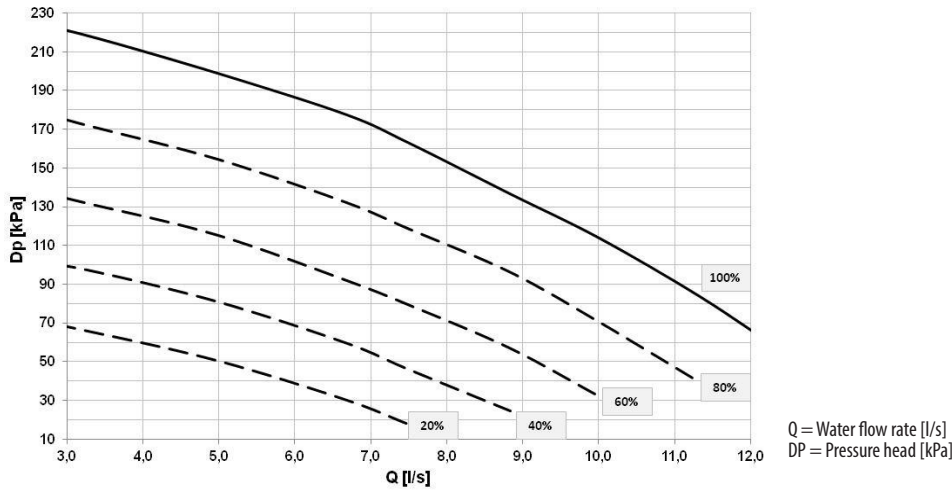

Caution: to obtain the available pressure values, you need to subtract the following from the head values represented in these diagrams:

- User side exchanger pressure drops
- IFVX accessory steel mesh filter on the water side (where applicable)

### Inverter pump absorption curve (Size 35.2 - 45.2)

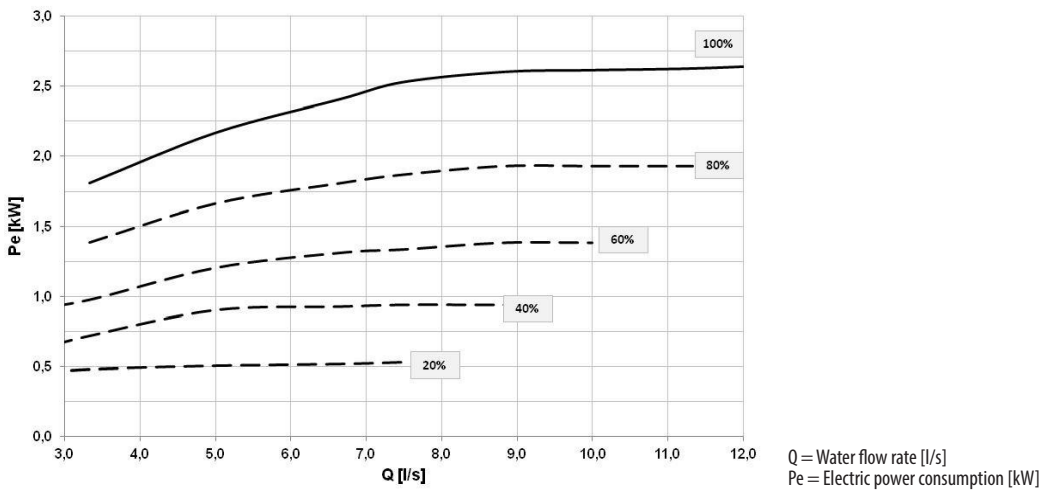

### Water diagram

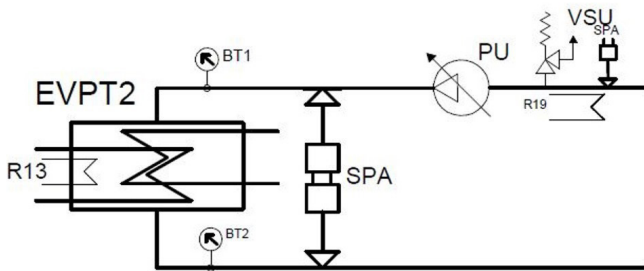

- EVPT2 = Plate evaporator 2 circuits
- R13 = Evaporator group heater
- BT1 = Probes of entering water temperature
- BT2 = Probes of leaving water temperature
- SPA1 = Differential water pressure switch
- PU = Hydronic assembly 1 inverter pump
- VSU = Water safety valve
- R19 = Hydronic assembly heaters
- SPA2 = System water pressure switch



## Configurations - Partial energy recovery (D)

Configuration with one recovery side brazed stainless steel (316 AISI) plate exchanger, and components per the legend of the enclosed plumbing circuit diagram. All water fittings are Victaulic type.

A configuration which enables the production of hot water free-of-charge while operating in the cooling mode, thanks to the partial recovery of condensation heat that would otherwise be rejected to the external heat source. It is possible to recovery about 20% of the unit rejected heating capacity equal to the sum of the cooling capacity and the compressor power input.

The partial recovery device is considered to be operating when it is powered by the water flow which is to be heated. This condition improves the unit performance, since it reduces the condensation temperature: in nominal conditions the cooling capacity increases indicatively by 3.2% and the power input of the compressors is reduced by 3.6%.

If cold water production is not requested, the unit can not produce hot water. The heating capacity request is made by the digital contact enabling, that activates the pump recovery side (outside the unit) The partial energy recovery option (D) can be matched to the hydronic assemblies user side indicated in the previous pages according to the diagrams below.

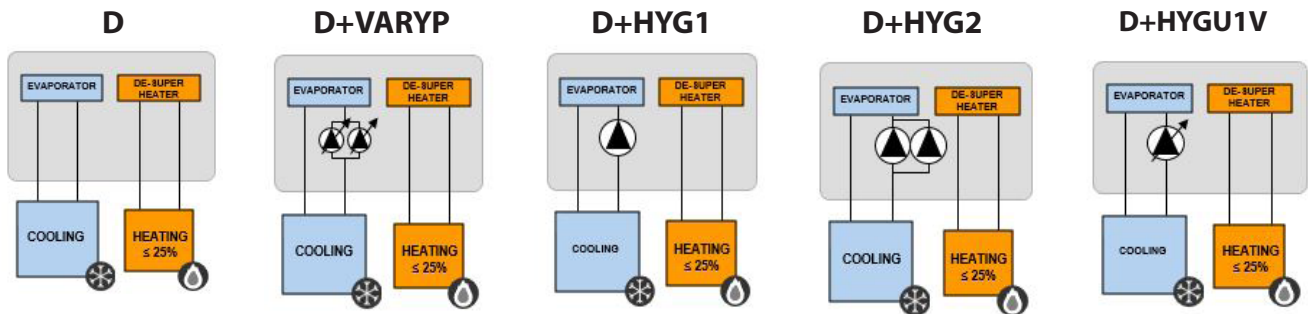

### Partial energy recovery pressure drop curves

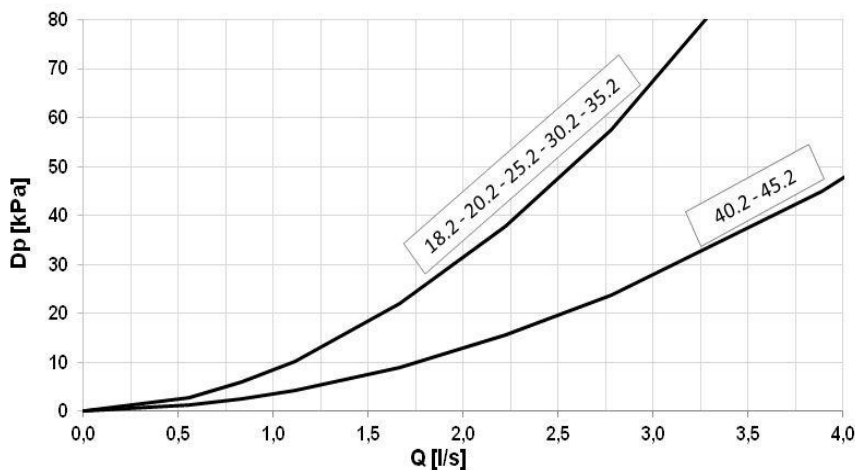

The pressure drops on the water side are calculated by considering an average water temperature at 7°C.  
 Q = Water flow rate [l/s]  
 DP = Pressure drops [kPa]

### Partial recovery heating capacity

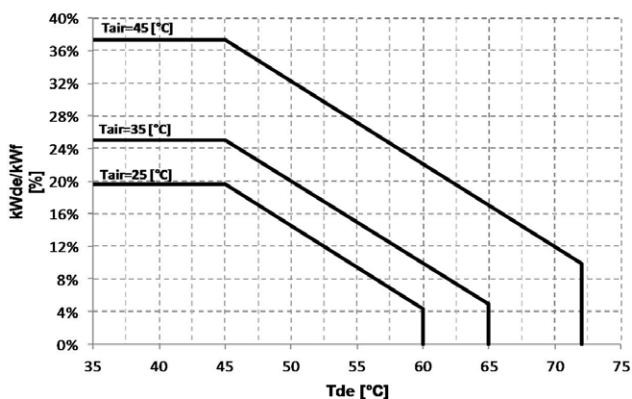

### Water diagram

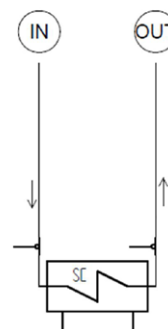

IN = Recovery side inlet  
 OUT = Recovery side outlet  
 SC = Plate heat exchangers

$kW_{del}/kW_f$  = Heat recovered/Cooling capacity [%]  
 Tde = Heat recovering device outlet water temperature [°C]

## Built-in configuration options

### ACC - Storage tank

Option supplied built-in the unit. Steel storage tank complete with double layer covering with closed-cell insulation, stainless steel anti-freeze immersion resistance, bleed valve, draw off cock, quick connections with insulated casing. The various available models can be differentiated by capacity.

Available only for size 35.2 ÷ 45.2.

The storage tank capacity is 150L.

### CCCA - Copper / aluminium condenser coil with acrylic lining

Coils with copper pipes and aluminium fins with acrylic lining. Resist bi-metallic corrosion and allow for application in coastal areas.

Attention!

- cooling capacity variation -2.7%
- variation in compressor power input +4.2%
- operating range reduction -2.1°C

### CCCA1 - Condenser coil with Aluminum Energy Guard DCC treatment

A treatment which offers an optimal thermal exchange and guarantees and protects the finned coil exchangers from corrosion over time. Can be used in settings with very aggressive saline concentrations and other chemical agents in the air thus maintaining the performance of the coils over time.

### PFCC - Power factor correction capacitors (cosφ>0,95)

The component is necessary to lower the phase difference between current and voltage in the electromagnetic components of the unit (e.g. asynchronous motors). The component allows to put the cosφ power factor to values on average higher than 0.95, reducing the network reactive power. This often leads to an economic benefit which the energy provider grants to the final user.

### MF2 - Multi-function phase monitor

Multifunction phase monitor supplied as standard: it controls the presence and the correct phase sequences, verifies possible voltage anomalies (-10%), it automatically resets the unit operation, when the correct power supply is re-established

This control allows to:

- protect components inside the unit, as if they are powered by an anomalous voltage they may operate incorrectly or break;
- quickly identify, among the alarms of the unit's components, the real cause of the malfunction due to the sudden change in voltage.

### SFSTR4N - Disposal for inrush current reduction, for unit 400/3/50+N

Electronic device that automatically and gradually starts the compressors, thereby reducing the current peak generated in star-triangle start-ups and therefore reduces the mechanical stress on the motor and the electrodynamic stress on the power cables and on the mains.

### PGFC – Finned coil protection grill

This accessory is used to protect the external coil from the accidental contact with external things or people. Ideal for installation in places where persons can pass from, such as car parks, terraces, etc.

### HEDIF - Diffuser for high efficiency axial fan

The new AxiTop diffuser creates an ideal air distribution: it aerodynamically decelerates the flow and transforms a big part of its kinetic energy in static pressure. Obtaining:

- down to -3 dB of silence
- reduction of 3% of the absorbed energy

Since the fans are the unit's main noise source, the benefits are evident especially during the night hours, when the load is reduced but sensitivity to noise is enhanced.

## CMSC8 - Serial communication module to BACnet supervisor

Allows the serial connection to supervision systems by using BACnet-IP as a communication protocol. It allows the access to the entire list of operating variables, controls and alarms. With this accessory every unit can communicate with the main supervision systems.

The device is built-in the unit.



The configuration and management activities for the BACnet networks are the responsibility of the client.



The total length of each serial line do not exceed 1000 meters and the line must be connected in bus typology (in/out)

## CMSC9 - Serial communication module to Modbus supervisor

This enables the serial connection of the supervision system, using Modbus as the communication protocol. It enables access to the complete list of operational variables, commands and alarms. Using this accessory every unit can dialogue with the main supervision systems.

The device is built-in the unit.



The total length of each serial line do not exceed 1000 meters and the line must be connected in bus typology (in/out)

## CMSC10 - Serial communication module to LonWorks supervisor

This enables the serial connection of the supervision system which uses the LonWorks communication protocol. It enables access to a list of operating variables, commands and alarms which comply with the Echelon® standard.

The device is built-in the unit.



The configuration and management activities for the LonWorks networks are the responsibility of the client.



LonWorks technology uses the LonTalk® protocol for communicating between the network nodes. Contact the service supplier for further information.

## Accessories separately supplied

### RCTX - Remote control

This option allows to have full control over all the unit functions from a remote position. It can be easily installed on the wall and has the same aspect and functions of the user interface on the unit.

- All device functions can be repeated with a normal portable PC connected to the unit with an Ethernet cable and equipped with an internet navigation browser.
- The device should be installed on the wall using suitable plugs, electrically hooked up and connected to the unit (installation and wiring are the responsibility of the Customer). Max. remote distance 350 m without auxiliary supply.
- Data and power supply serial connection cable n.1 twisted and shielded pair. Diameter of the individual conductor 0.8 mm.
- Installation provided by the Customer.

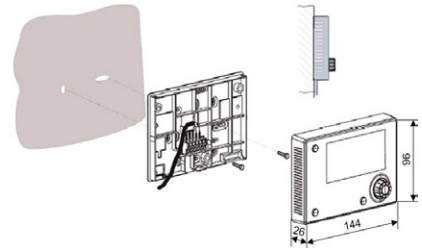

### BACX - BACnet serial communication module

Allows the serial connection to supervision systems by using BACnet-IP as a communication protocol. It allows the access to the entire list of operating variables, controls and alarms. With this accessory every unit can communicate with the main supervision systems.

- The configuration and management activities for the BACnet networks are the responsibility of the client.
- The total length of each serial line do not exceed 1000 meters and the line must be connected in bus typology (in/out)
- Installation provided by the Customer.

### CMMBX - Serial communication module to supervisor (Modbus)

This enables the serial connection of the supervision system, using Modbus as the communication protocol. It enables access to the complete list of operational variables, commands and alarms. Using this accessory every unit can dialogue with the main supervision systems.

The device is installed and wired built-in the unit.

- The total length of each serial line do not exceed 1000 meters and the line must be connected in bus typology (in/out)
- Installation provided by the Customer.

### CMSLWX - LonWorks serial communication module

This enables the serial connection of the supervision system which uses the LonWorks communication protocol. It enables access to a list of operating variables, commands and alarms which comply with the Echelon® standard.

The device is installed and wired built-in the unit.

- The configuration and management activities for the LonWorks networks are the responsibility of the client.
- LonWorks technology uses the LonTalk® protocol for communicating between the network nodes. Contact the service supplier for further information.
- Installation provided by the Customer.

### PGFCX - Finned coil protection grill

This accessory is used to protect the external coil from the accidental contact with external things or people. Ideal for installation in places where persons can pass from, such as car parks, terraces, etc. The accessory is supplied installed built-in the unit.

- This option is not suitable for application in sulphuric environments
- Installation provided by the Customer.

## AVIBX - Anti-vibration mount support

The rubber antivibration mounts are attached in special housing on the support frame and serve to smooth the vibrations produced by the unit thus reducing the noise transmitted to the support structure.

 Installation provided by the Customer.

## IFWX - Steel mesh strainer on the water side

The device prevents any impurity in the hydraulic circuit from soiling the exchanger. The stainless steel mesh mechanical filter must be placed on the water inlet line. It needs to be easy to remove for periodical maintenance and cleaning operations.

Moreover, it consists of:

- cast-iron shut-off butterfly valve with quick coupling and throttle drive and mechanical calibration stop
- quick couplings with an insulated casing

 Installation provided by the Customer.

## Steel mesh strainer pressure drops

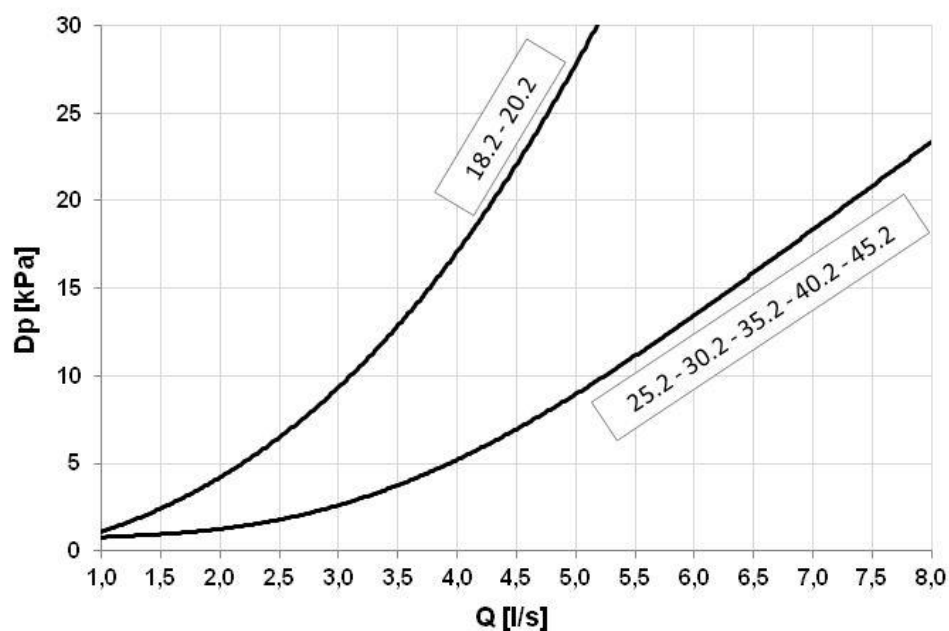

Q = Water flow rate [l/s]  
 DP = Water side pressure drops [kPa]

## Cooling performance

Size	To (°C)	Entering external exchanger air temperature (°C)											
		20		25		30		35		40		45	
		kWf	kWe	kWf	kWe	kWf	kWe	kWf	kWe	kWf	kWe	kWf	kWe
18.2	5	52,7	10,2	51,1	11,2	49,3	12,2	47,1	13,3	43,8	14,6	39,9	16,1
	7	56,2	10,4	54,6	11,4	52,6	12,4	50,3	13,5	46,8	14,8	42,6	16,3
	10	62,0	10,7	60,2	11,7	58,0	12,7	55,3	13,9	51,3	15,1	46,6	16,6
	12	65,8	10,9	63,7	11,9	61,5	12,9	58,5	14,1	54,1	15,3	-	-
	15	71,7	11,2	69,5	12,2	66,9	13,2	63,8	14,4	58,9	15,7	-	-
	18	78,0	11,5	75,3	12,5	72,6	13,6	69,1	14,7	63,9	16,0	-	-
20.2	5	66,2	13,5	63,8	14,7	61,6	16,1	59,1	17,5	54,3	19,2	49,6	21,1
	7	70,7	13,8	68,1	15,0	65,8	16,3	63,0	17,8	57,7	19,5	52,7	21,4
	10	77,5	14,2	74,6	15,4	71,9	16,8	68,8	18,3	63,1	19,9	57,6	21,8
	12	82,0	14,5	78,9	15,7	76,0	17,1	72,7	18,6	66,4	20,3	-	-
	15	89,4	15,0	85,8	16,2	82,6	17,6	78,7	19,1	72,3	20,8	-	-
	18	96,4	15,4	92,5	16,7	88,8	18,1	84,6	19,6	77,5	21,2	-	-
25.2	5	78,3	15,9	75,5	17,2	73,1	18,7	69,8	20,3	64,7	22,3	58,9	24,5
	7	83,7	16,2	80,7	17,5	78,2	19,0	74,6	20,6	69,0	22,6	62,7	24,8
	10	91,8	16,7	88,6	18,1	85,6	19,5	81,6	21,1	75,4	23,1	68,6	25,2
	12	97,4	17,1	93,8	18,4	90,6	19,9	86,4	21,5	79,8	23,4	-	-
	15	106	17,7	102	19,0	98,5	20,5	93,9	22,0	86,6	24,0	-	-
	18	115	18,3	110	19,6	106	21,0	101	22,5	92,8	24,5	-	-
30.2	5	92,3	18,9	89,0	20,5	85,7	22,1	81,7	24,0	74,9	26,1	68,7	28,5
	7	98,1	19,3	94,4	20,8	90,9	22,5	86,5	24,4	79,3	26,5	72,8	29,0
	10	107	19,9	103	21,5	99,5	23,2	94,4	25,1	86,5	27,2	79,3	29,6
	12	114	20,4	110	22,0	106	23,7	101	25,6	92,0	27,7	-	-
	15	125	21,3	120	22,8	115	24,5	109	26,4	100	28,5	-	-
	18	134	21,9	128	23,5	123	25,1	116	27,1	107	29,1	-	-
35.2	5	105	22,1	102	23,7	98,4	25,5	93,8	27,5	86,6	29,9	79,1	32,7
	7	112	22,5	108	24,1	104	26,0	99,5	28,0	91,7	30,3	83,9	33,1
	10	122	23,3	118	24,8	114	26,7	108	28,7	100	31,1	91,3	33,9
	12	130	23,8	125	25,3	120	27,3	114	29,2	105	31,6	-	-
	15	141	24,6	136	26,1	131	28,0	124	30,0	115	32,4	-	-
	18	153	25,4	147	27,0	141	28,9	134	30,8	123	33,2	-	-
40.2	5	121	25,4	117	27,4	112	29,7	107	32,2	98,1	35,2	89,3	38,6
	7	128	25,9	123	27,9	119	30,2	113	32,6	103	35,7	94,3	39,0
	10	139	26,6	134	28,7	129	30,9	122	33,4	112	36,5	103	39,8
	12	149	27,2	143	29,4	137	31,6	130	34,0	119	37,1	-	-
	15	163	28,4	156	30,5	149	32,7	141	35,0	130	38,1	-	-
	18	174	29,2	167	31,3	159	33,5	150	35,8	138	38,9	-	-
45.2	5	135	27,5	129	30,1	125	32,9	119	35,9	109	39,2	98,8	42,7
	7	142	28,1	136	30,6	131	33,4	125	36,4	114	39,7	104	43,2
	10	154	29,0	148	31,5	142	34,3	135	37,4	124	40,7	113	44,1
	12	164	29,7	157	32,3	151	35,1	143	38,1	131	41,3	-	-
	15	180	30,8	172	33,4	165	36,2	156	39,2	143	42,4	-	-
	18	192	31,8	183	34,3	176	37,1	166	40,1	152	43,3	-	-

kWf = Internal exchanger cooling capacity (kW)

kWe = Compressor power input (kW)

To (°C) = Leaving internal exchanger water temperature (°C)

Performances in function of the entering/leaving water temperature differential = 5°C

# Dimensional drawings

## Size 18.2 - 20.2

DACM20003\_40.2\_45.2\_0  
29/04/2019

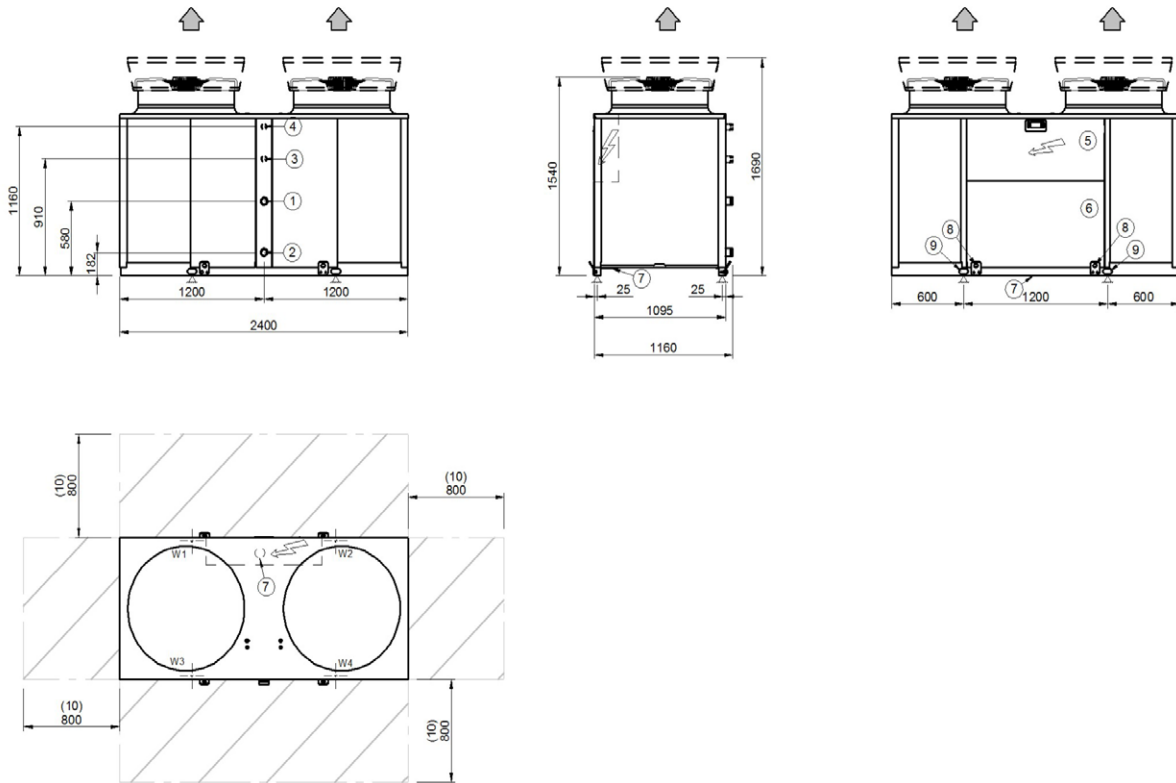

1. Water inlet user side Ø 2" Victaulic
2. Water outlet user side Ø 2" Victaulic
3. Water inlet recovery side Ø 1" 1/4 Victaulic (optional)
4. Water outlet recovery side Ø 1" 1/4 Victaulic (optional)
5. General electrical panel
6. Compressor compartment
7. Power input
8. Lifting brackets (removable)
9. Unit fixing holes Ø 18mm
10. Clearance access recommended

Size		18.2	20.2
A - Length	mm	2400	2400
B - Width	mm	1160	1160
C - Standard unit height	mm	1540	1540
C - Height with HEDIF option	mm	1690	1690
W1 Supporting Point	kg	160	164
W2 Supporting Point	kg	157	161
W3 Supporting Point	kg	135	136
W4 Supporting Point	kg	133	134
Operating weight	kg	585	595
Shipping weight	kg	575	585

The presence of optional accessories may result in a substantial variation of the weights shown in the table.

# Dimensional drawings

## Size 25.2 - 30.2

DACM225.2\_30.2\_1  
29/04/2019

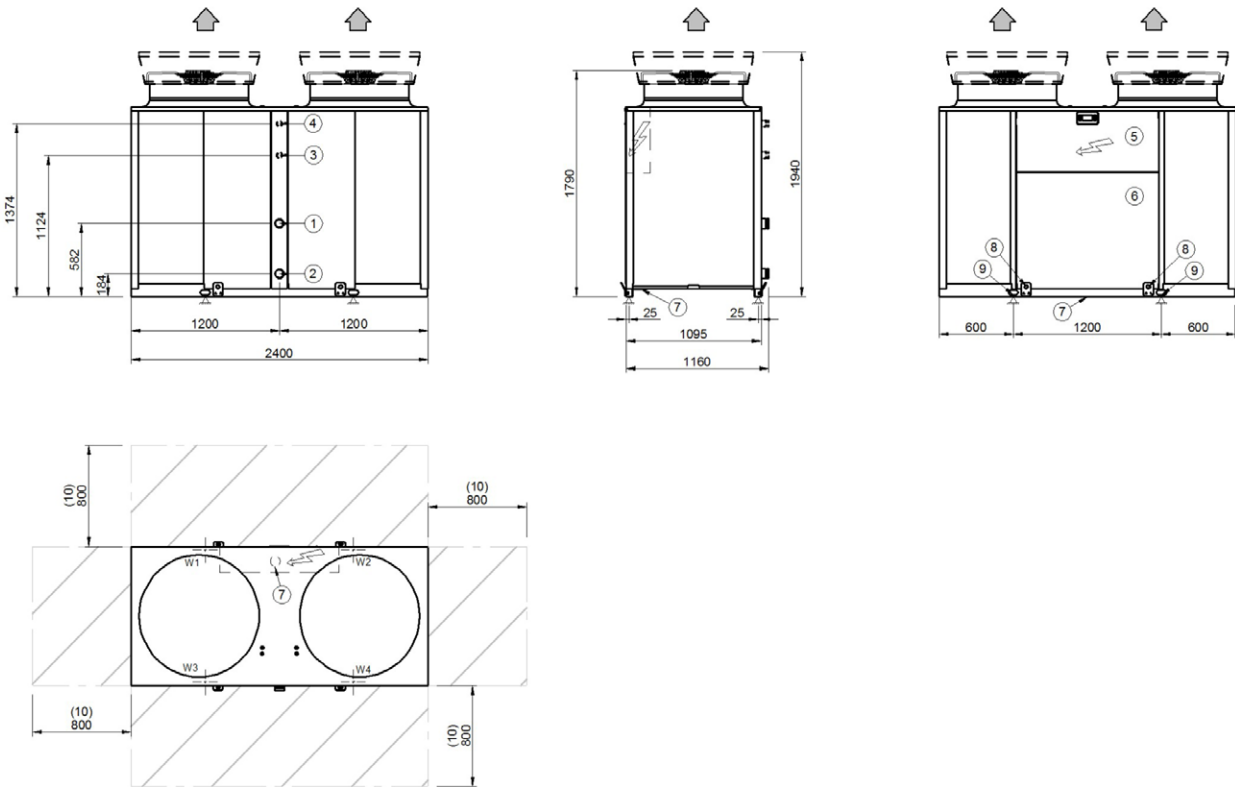

1. Water inlet user side Ø 2" 1/2 Victaulic
2. Water outlet user side Ø 2" 1/2 Victaulic
3. Water inlet recovery side Ø 1" 1/4 Victaulic (optional)
4. Water outlet recovery side Ø 1" 1/4 Victaulic (optional)
5. General electrical panel
6. Compressor compartment
7. Power input
8. Lifting brackets (removable)
9. Unit fixing holes Ø 18mm
10. Clearance access recommended

Size		25.2	30.2
A - Length	mm	2400	2400
B - Width	mm	1160	1160
C - Standard unit height	mm	1790	1790
C - Height with HEDIF option	mm	1940	1940
W1 Supporting Point	kg	180	196
W2 Supporting Point	kg	180	194
W3 Supporting Point	kg	137	144
W4 Supporting Point	kg	137	142
Operating weight	kg	634	676
Shipping weight	kg	620	661

The presence of optional accessories may result in a substantial variation of the weights shown in the table.



# Dimensional drawings

Size 35.2 - 40.2 - 45.2

DACM20003\_40.2\_45.2\_0  
29/04/2019

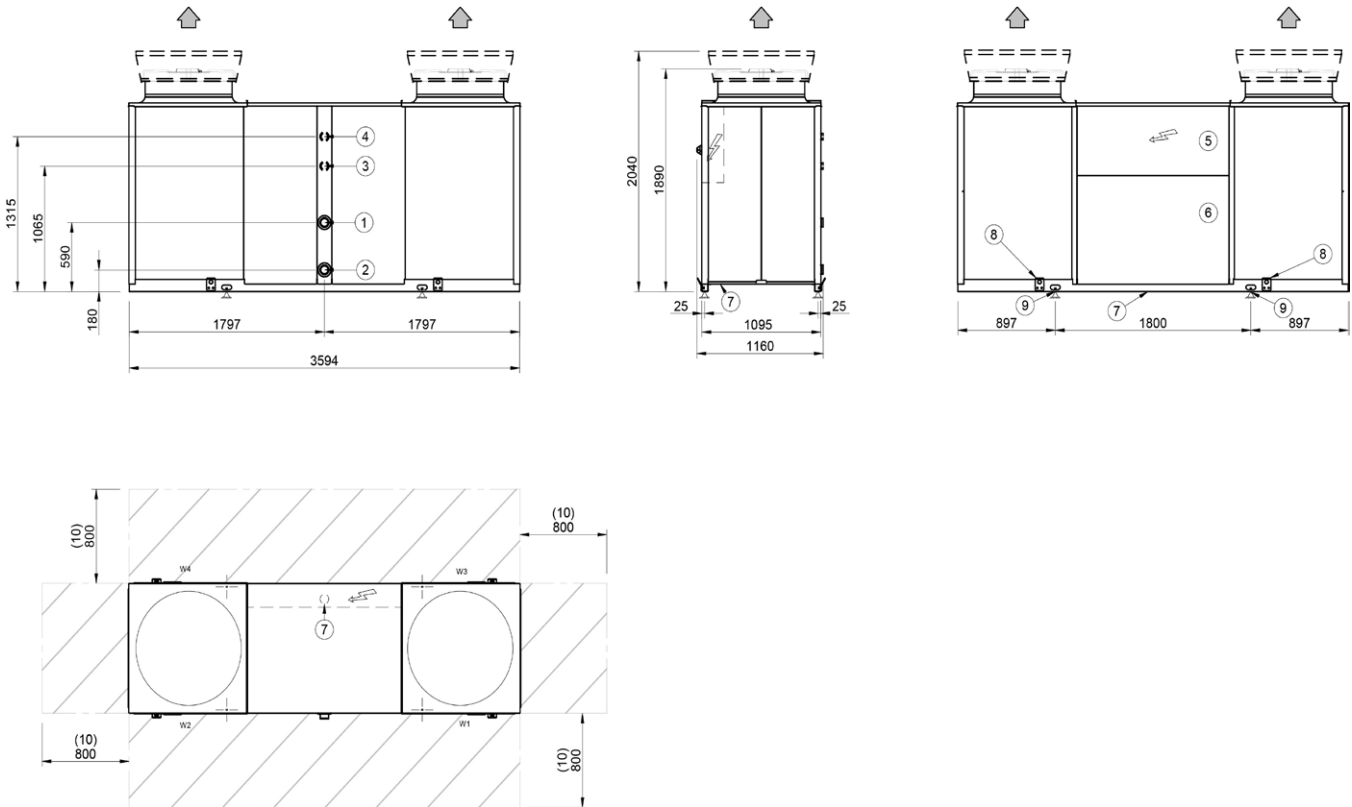

1. Water inlet user side  $\text{Ø} 2'' 1/2$  Victaulic
2. Water outlet user side  $\text{Ø} 2'' 1/2$  Victaulic
3. Water inlet recovery side  $\text{Ø} 1'' 1/2$  Victaulic
4. Water outlet recovery side  $\text{Ø} 1'' 1/2$  Victaulic
5. General electrical panel
6. Compressor compartment
7. Power input
8. Lifting brackets (removable)
9. Unit fixing holes  $\text{Ø} 18\text{mm}$
10. Clearance access recommended

Size		35.2	40.2	45.2
A - Length	mm	3600	3600	3600
B - Width	mm	1160	1160	1160
C - Standard unit height	mm	1890	1890	1890
C - Height with HEDIF option	mm	2040	2040	2040
W1 Supporting Point	kg	183	195	205
W2 Supporting Point	kg	184	193	207
W3 Supporting Point	kg	223	237	254
W4 Supporting Point	kg	223	235	257
Operating weight	kg	813	860	923
Shipping weight	kg	802	849	913

The presence of optional accessories may result in a substantial variation of the weights shown in the table.

Page intentionally left blank

Page intentionally left blank

FOR OVER 30 YEARS WE HAVE BEEN  
OFFERING SOLUTIONS TO ENSURE  
SUSTAINABLE COMFORT AND THE WELL-  
BEING OF PEOPLE AND THE ENVIRONMENT

[www.clivet.com](http://www.clivet.com)

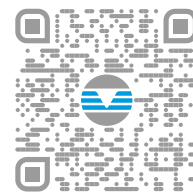

sale and assistance

ELFOENERGY MAGNUM - BT19F018GB-02



**CLIVET SPA**

Via Camp Lonc 25, Z.I. Villapaiera  
32032 Feltre (BL) - Italy  
Tel. +39 0439 3131 - Fax +39 0439 313300  
[info@clivet.it](mailto:info@clivet.it)

A Group Company of

